



Designation: G 7 – 97

Standard Practice for Atmospheric Environmental Exposure Testing of Nonmetallic Materials¹

This standard is issued under the fixed designation G 7; the number immediately following the designation indicates the year of original adoption or, in the case of revision, the year of last revision. A number in parentheses indicates the year of last reapproval. A superscript epsilon (ε) indicates an editorial change since the last revision or reapproval.

1. Scope

1.1 This practice covers procedures to be followed for direct exposure of nonmetallic materials to the environment. When originators of a weathering test have the actual exposure conducted by a separate agency, the specific conditions for the exposure of test and control specimens should be clearly defined and mutually agreed upon between all parties.

1.2 For exposures behind glass, refer to Practice G 24.

1.3 The values stated in SI units are to be regarded as the standard. The inch-pound units given in parentheses are for information only.

1.4 This practice is technically equivalent to the parts of ISO 877 that describe direct exposures of specimens to the environment.

1.5 *This standard does not purport to address all of the safety concerns, if any, associated with its use. It is the responsibility of the user of this standard to establish appropriate safety and health practices and determine the applicability of regulatory limitations prior to use.*

2. Referenced Documents

2.1 ASTM Standards:

E 41 Terminology Relating to Conditioning²

E 824 Test Method for Transfer of Calibration from Reference to Field Pyranometers³

E 913 Test Method for Calibration of Reference Pyranometers with Axis Vertical by the Shading Method³

E 941 Test Method for Calibration of Reference Pyranometers with Axis Tilted by the Shading Method³

G 24 Practice for Conducting Exposures to Daylight Filtered Through Glass²

G 113 Terminology Relating to Natural and Artificial Weathering Tests of Nonmetallic Materials²

2.2 ASTM Adjunct:

Adjunct No. 12-700070-00 A Test Rack⁴

2.3 ISO Standards:

ISO 877 Plastics—Methods of Exposure to Direct Weathering; to Weathering Using Glass-Filtered Daylight, and to Intensified Weathering by Daylight Using Fresnel Mirrors⁵

3. Terminology

3.1 *Definitions*—The definitions given in Terminology E 41 and Terminology G 113 are applicable to this practice.

4. Significance and Use

4.1 The relative durability of materials in natural exposures can be very different depending on the location of the exposure because of differences in ultraviolet (UV) radiation, time of wetness, temperature, pollutants, and other factors. Therefore, it cannot be assumed that results from one exposure in a single location will be useful for determining relative durability in a different location. Exposures in several locations with different climates which represent a broad range of anticipated service conditions are recommended.

4.2 Because of year-to-year climatological variations, results from a single exposure test cannot be used to predict the absolute rate at which a material degrades. Several years of repeat exposures are needed to get an “average” test result for a given location.

4.3 Solar ultraviolet radiation varies considerably as a function of time of year. This can cause large differences in the apparent rate of degradation in many polymers. Comparing results for materials exposed for short periods (less than one year) is not recommended unless materials are exposed at the same time in the same location.

4.4 Defining exposure periods in terms of total solar or solar-ultraviolet radiant energy can reduce variability in results from separate exposures. Solar ultraviolet measurements may be made using instruments which record broadband UV (e.g.

¹ This practice is under the jurisdiction of ASTM Committee G-3 on Durability of Nonmetallic Materials and is the direct responsibility of Subcommittee G03.02 on Natural Environmental Testing.

Current edition approved Dec. 10, 1997. Published February 1998. Originally published as G 7 – 69T. Last previous edition G 7 – 96.

² *Annual Book of ASTM Standards*, Vol 14.02.

³ *Annual Book of ASTM Standards*, Vol 12.02.

⁴ Available from ASTM Headquarters, 100 Barr Harbor Dr., West Conshohocken, PA 19428. Request ADJG0007.

⁵ Available from the American National Standards Institute (ANSI), 1430 Broadway, New York, NY 10018.

295 ± 385 nm) or narrow band UV, as defined in Sections 7.2.4 and 7.2.5. An inherent limitation in solar-radiation measurements is that they do not reflect the effects of temperature and moisture, which are often as important as solar radiation.

4.5 The design of the exposure rack, the location of the specimen on the exposure rack, and the type or color of adjacent specimens can affect specimen temperature and time of wetness. In order to minimize variability caused by these factors, it is recommended that test specimens, control specimens, and any applicable weathering reference material be placed on a single test panel or on test panels placed adjacent to each other during exposure.

4.6 It is strongly recommended that at least one control material be part of any exposure evaluation. The control material should meet the requirements of Terminology G 113, and should be of similar composition and construction compared to test specimens. It is preferable to use two control materials, one with relatively good durability and one with relatively poor durability. Unless otherwise specified, use at least two replicate specimens of each test and control material being exposed. Control materials included as part of a test shall be used for the purpose of comparing the performance of test materials relative to the controls.

5. Test Sites, Location of Test Fixtures, and Exposure Orientation

5.1 *Test Sites*—Exposures can be conducted in any type of climate. However, in order to get more rapid indications of outdoor durability, exposures are often conducted in locations that receive high levels of solar radiation, temperature, and moisture. Typically, these conditions are found in hot desert and subtropical or tropical climates. Known attributes of the use environment should be represented by the locations selected for outdoor durability evaluation. For example, if the use environment for the product being evaluated will include freeze/thaw cycling, specimen exposure in a northern temperature climate is recommended. In addition, exposures are often conducted in areas where specimens are subjected to salt air (seashore) or industrial pollutants.

5.1.1 Unless otherwise specified, test fixtures or racks shall be located in cleared areas. The area beneath and in the vicinity of the test fixtures should be characterized by low reflectance and by ground cover typical of the climatological area where the exposures are being conducted. In desert areas, the ground is often gravel to control dust and in most temperate areas, the ground cover should be low-cut grass. The type of ground cover at the exposure site shall be indicated in the test report. If test fixtures are placed on a rooftop, specimens may be subjected to different environmental conditions than at ground level. These differences may affect test results.

5.2 The lowest row of specimens on a test fixture or rack shall be positioned at a height above the ground to avoid contact with vegetation and to prevent damage that might occur during area maintenance. A minimum height of 0.45 m (18 in.) above the ground is recommended.

5.3 Test fixtures shall be placed in a location so that there is no shadow on any specimen when the sun's angle of elevation is greater than 20°.

5.4 *Exposure Orientation*—Unless otherwise specified, exposure racks shall be oriented so that specimens face the equator. Specimens can be exposed at a number of different orientations or “exposure angles” in order to simulate end-use conditions of the material being evaluated. Typical exposure angles are as follows:

5.4.1 *Latitude Angle*—Exposure rack is positioned so that the exposed surface of specimens are at an angle from the horizontal that is equal to the geographical latitude of the exposure site.

5.4.2 *45°*—Exposure rack is positioned so that the exposed specimens are at an angle of 45° from the horizontal. This is the most commonly used exposure orientation.

5.4.3 *90°*—Exposure rack is positioned so that the exposed specimens are at an angle of 90° from the horizontal.

5.4.4 *5°*—Exposure rack is positioned so that the exposed specimens are at an angle of 5° from the horizontal. This angle is preferred over horizontal exposure to avoid standing water on specimens being exposed. This exposure angle typically receives the highest levels of solar radiation during mid-summer and is used to test materials that would normally be used in horizontal or nearly horizontal applications.

NOTE 1—Exposures conducted at less than the site latitude typically receive more ultraviolet radiation than exposures conducted at larger angles.

5.4.5 Any other angle that is mutually agreed on by all interested parties may be used. In some instances, exposures facing directly away from the equator or some other specific direction may be desired. The test report shall contain the exact angle and specimen orientation of any exposure condition outside of those described in 5.4.1-5.4.4.

5.5 *Specimen Backing*—Three types of specimen backing can be used. Comparisons between materials should only be made with exposures conducted with the same specimen backing.

5.5.1 *Unbacked Exposures*—Specimens are exposed so that the portion of the test specimen being evaluated is subjected to the effects of the weather on all sides.

5.5.2 *Backed Exposures*—Specimens are attached to a solid substrate so that only the front surface is exposed. Surface temperatures of specimens in backed exposures will be higher than for specimens subjected to unbacked exposures. In some cases, the substrate is painted black, which produces significant differences in surface temperature compared to exposures conducted on unpainted substrate. This can cause large differences in degradation rates when compared to backed exposures conducted on unpainted substrates.

5.5.3 *Black Box Exposure*—Specimens are attached to the front face of a black painted aluminum box (see 6.2.3). The specimens form the top surface of the box. If there are not enough test specimens to completely cover the top surface, open areas shall be filled with black painted sheet metal panels so that the box is completely closed.

6. Construction of Test Fixtures (Exposure Racks)

6.1 *Materials of Construction*—All materials used for test fixtures shall be noncorrodible without surface treatment. Aluminum Alloys 6061T6 or 6063T6 have been found suitable

for use in most locations. Properly primed and coated steel is suitable for use in desert areas. Monel has been found suitable in highly corrosive areas. Untreated wood is acceptable in desert areas but may pose maintenance problems in other areas. (See Fig. 1.)

6.1.1 For backed exposures (see 6.2.2 and Fig. 2), use exterior-grade plywood to form a solid surface to which specimens are directly attached. Replace the plywood when there is any evidence of delamination or fiber separation. Medium-density overlay (MDO) or high-density overlay (HDO) plywood are satisfactory substrates and require less frequent replacement than plywood with no overlay. The edges of the plywood should be sealed with a durable paint to prevent delamination.

6.2 *Test Fixture Design*—Test racks shall be constructed to hold specimens or specimen holders of any convenient width and length. Racks shall be constructed so that any contamination from specimens higher on the fixture cannot run down onto specimens in lower positions. Test racks should be designed to provide backed or unbacked exposures, whichever best simulates end-use conditions.⁶

6.2.1 *Unbacked Exposures*—Test racks shall be constructed so that most of the test specimen is exposed to the effects of the weather on all sides. Specimens are attached to the test fixture at the top or bottom, or both, using clamping devices, properly spaced slots, or mechanical fasteners. The method of attach-

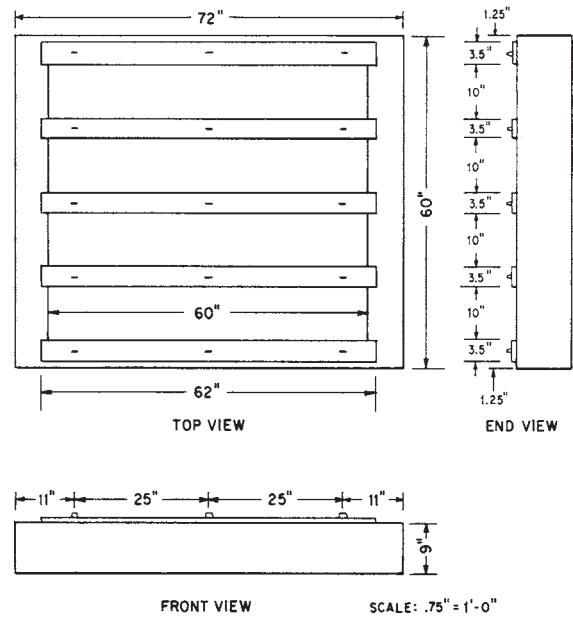
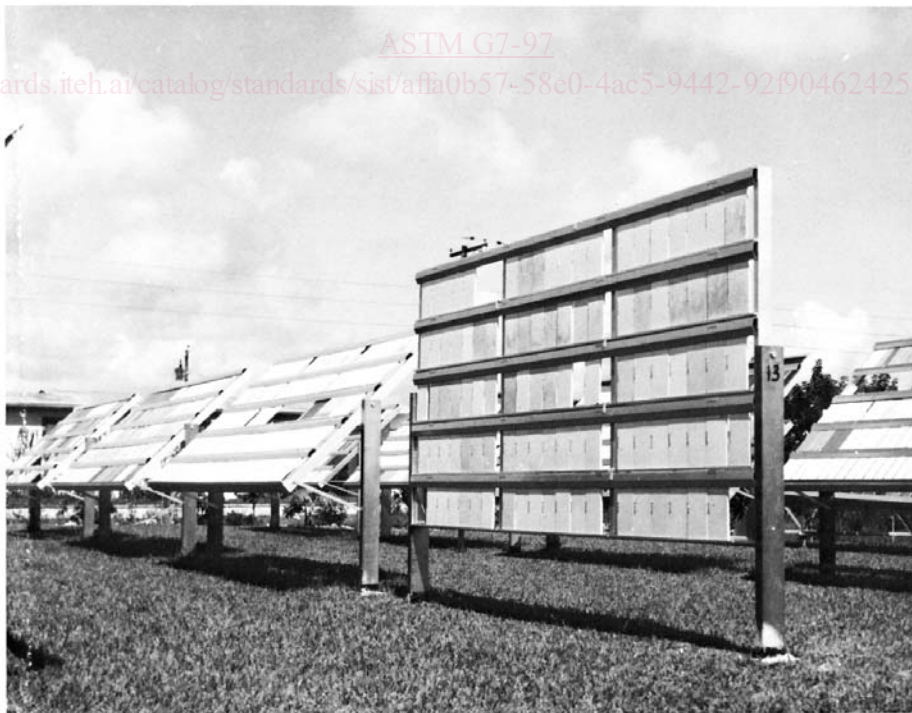

FIG. 3 Black Box

ment shall not prevent expansion and contraction of specimens caused by temperature or moisture. Use fastening devices for attaching specimens to the test fixture that will not corrode or degrade and contaminate the specimens. Aluminum, properly galvanized steel, or stainless steel fasteners are recommended.

6.2.2 *Backed Exposures*—Test racks shall be constructed so that specimens are attached to a plywood substrate. The

⁶ Detailed drawings for an acceptable test rack may be obtained from ASTM Headquarters. Request ADJG0007.



NOTE 1—Detailed drawings of this test rack may be obtained from ASTM Headquarters, 100 Barr Harbor Dr., W. Conshohocken, PA 19428. Request Adjunct No. 12-700070-00.

FIG. 1 Typical Exposure Rack