



Standard Test Method for Measuring Air Performance Characteristics of Vacuum Cleaners¹

This standard is issued under the fixed designation F558; the number immediately following the designation indicates the year of original adoption or, in the case of revision, the year of last revision. A number in parentheses indicates the year of last reapproval. A superscript epsilon (ϵ) indicates an editorial change since the last revision or reapproval.

1. Scope

1.1 This test method covers procedures for determining air performance characteristics of commercial and household upright, canister, stick, hand-held, utility, and combination-type vacuum cleaners having provisions for attaching a hose and incorporating a series universal motor. This test method can be applied to the carpet cleaning mode of operation.

1.2 These tests and calculations include determination of suction, airflow, air power, maximum air power, and input power under standard operating conditions (see **Note 1**). The nozzle mounted on plenum testing is an ideal air performance measurement and is not intended to represent the actual air performance during carpet or floor cleaning.

NOTE 1—For more information on air performance characteristics, see Refs (1-6).²

1.3 The foot-pound-inch system of units is used in this standard. The values in parentheses are given for information only.

1.4 This standard may involve hazardous materials, operations, and equipment. *This standard does not purport to address all of the safety concerns, if any, associated with its use. It is the responsibility of the user of this standard to establish appropriate safety, health, and environmental practices and determine the applicability of regulatory limitations prior to use.* A specific precautionary statement is given in **Note 2**.

1.5 *This international standard was developed in accordance with internationally recognized principles on standardization established in the Decision on Principles for the Development of International Standards, Guides and Recommendations issued by the World Trade Organization Technical Barriers to Trade (TBT) Committee.*

2. Referenced Documents

2.1 *ASTM Standards:*³

E1 Specification for ASTM Liquid-in-Glass Thermometers

E177 Practice for Use of the Terms Precision and Bias in ASTM Test Methods

E691 Practice for Conducting an Interlaboratory Study to Determine the Precision of a Test Method [9/astm-f558-17a](#)

E2251 Specification for Liquid-in-Glass ASTM Thermometers with Low-Hazard Precision Liquids

F431 Specification for Air Performance Measurement Plenum Chamber for Vacuum Cleaners

2.2 *AMCA Standard:*⁴

210-85 Laboratory Methods of Testing Fans for Rating

2.3 *IEC Standard:*⁵

IEC 60342-Ed 3.262885-2 [Surface Cleaning Appliances – Part 2: Dry Vacuum Cleaners for Household Use – Methods of or Similar Use – Methods for Measuring the Performance](#)

3. Terminology

3.1 *Definitions:*

3.1.1 *air power, AP, W, n*—in a vacuum cleaner, the net time rate of work performed by an air stream while expending energy to produce an airflow by a vacuum cleaner under specified air resistance conditions.

¹ This test method is under the jurisdiction of ASTM Committee **F11** on Vacuum Cleaners and is the direct responsibility of Subcommittee **F11.22** on Air Performance. Current edition approved March 1, 2017. Published March 2017. Originally approved in 1978. Last previous edition approved in 2013 as **F558 – 13 F558 – 17**. DOI: [10.1520/F0558-17.10.1520/F0558-17A](#).

² The boldface numbers in parentheses refer to the list of references appended to this test method.

³ For referenced ASTM standards, visit the ASTM website, [www.astm.org](#), or contact ASTM Customer Service at [service@astm.org](#). For *Annual Book of ASTM Standards* volume information, refer to the standard's Document Summary page on the ASTM website.

⁴ Available from Air Movement and Control Association, 30 West University Dr., Arlington Heights, IL, 60004.

⁵ Available from the IEC Web store, [webstore.iec.ch](#), or American National Standards Institute (ANSI), 25 W. 43rd St., 4th Floor, New York, NY 10036.

3.1.2 *automatic bleed valve, n*—any device a part of a vacuum cleaner’s design which automatically introduces an intentional leak within the vacuum cleaner’s system when manufacturer specified conditions are met.

3.1.3 *corrected airflow, Q, cfm, n—in a vacuum cleaner*, the volume of air movement per unit of time under standard atmospheric conditions.

3.1.4 *input power, W, n*—the rate at which electrical energy is absorbed by a vacuum cleaner.

3.1.5 *model, n*—the designation of a group of vacuum cleaners having the same mechanical and electrical construction with only cosmetic or nonfunctional differences.

3.1.6 *population, n*—the total of all units of a particular model vacuum cleaner being tested.

3.1.7 *repeatability limit (r), n*—the value below which the absolute difference between two individual test results obtained under repeatability condition may be expected to occur with a probability of approximately 0.95 (95 %).

3.1.8 *repeatability standard deviation (S_r), n*—the standard deviation of test results obtained under repeatability conditions.

3.1.9 *reproducibility limit (R), n*—the value below which the absolute difference between two test results obtained under reproducibility conditions may be expected to occur with a probability of approximately 0.95 (95 %).

3.1.10 *reproducibility standard deviation (S_R), n*—the standard deviation of test results obtained under reproducibility conditions.

3.1.11 *sample, n*—a group of vacuum cleaners taken from a large collection of vacuum cleaners of one particular model which serves to provide information that may be used as a basis for making a decision concerning the larger collection.

3.1.12 *standard air density, ρ_{std}, lb/ft³, n*—atmospheric air density of 0.075 lb/ft³ (1.2014 Kg/m³).

3.1.12.1 Discussion—

This value of air density corresponds to atmospheric air at a temperature of 68°F (20°C), 14.696 psi (101.325 kPa), and approximately 30 % relative humidity.

3.1.13 *suction, inch of water, n—in a vacuum cleaner*, the absolute difference between ambient and subatmospheric pressure.

3.1.14 *test run, n*—the definitive procedure that produces the singular result of calculated maximum air power.

3.1.15 *test station pressure, B_p, inch of mercury, n—for a vacuum cleaner*, the absolute barometric pressure at the test location (elevation) and test time.

3.1.15.1 Discussion—

ASTM F558-17a

It is not the equivalent mean sea level value of barometric pressure typically reported by the airport and weather bureaus. It is sometimes referred to as the uncorrected barometric pressure (that is, not corrected to the mean sea level equivalent value). Refer to 5.5 for additional information.

3.1.16 *unit, n*—a single vacuum cleaner of the model being tested.

4. Significance and Use

4.1 The test results allow the comparison of the maximum potential air power available for cleaning tasks when tested under the conditions of this test method. The test results do not indicate the actual air power present during the cleaning process due to the effects of the various tools in use and surfaces being cleaned. During the nozzle on plenum chamber air performance testing, the brushroll is unloaded and this condition is not representative of the brushroll being in contact with carpet or other surfaces being cleaned.

5. Apparatus

5.1 *Plenum Chamber*—See Specification F431 or IEC 60312, Section 5.2.8.2 (Figure 13e)-62885-2, Section 5.8.3.

5.2 *Water Manometers*, or equivalent instruments. One to measure from 0 to 6 in. (152.4 mm) in increments of 0.01 in. (0.254 mm), and one with increments of 0.1 in. (2.54 mm) for use in making measurements above 6 in. (152.4 mm). A single instrument having a resolution of 0.01 in. (0.254 mm) over the entire required range may be used instead of two separate instruments.

5.3 *Wattmeter*, to provide measurements accurate to within ±1 %.

5.4 *Voltmeter*, to provide measurements accurate to within ±1 %.

5.5 *Barometer*, with an accuracy of ±0.05 in. of mercury (1.27 mm of mercury), capable of measuring and displaying absolute barometric pressure, scale divisions 0.02 in. (0.51 mm) or finer.

5.5.1 Mercury barometers, in general, measure and display the absolute barometric pressure. Some corrections may be needed for temperature and gravity. Consult the owner’s manual.

5.5.2 When purchasing an aneroid or electronic barometer, be sure to purchase one which displays the absolute barometric pressure, not the mean sea level equivalent barometric pressure value. These types of barometers generally have temperature compensation built into them and do not need to be corrected for gravity.

5.6 *Sharp-Edge Orifice Plates*—See specifications in Specification **F431**.

5.7 *Thermometer*—Solid-stem, ambient thermometer having a range from 18 to 89°F (or –8 to +32°C) with graduations in 0.2°F (0.1°C), conforming to the requirements for thermometer 63°F (17.2°C) as prescribed in Specification **E1**. As an alternative, thermometers S63F or S63C, as prescribed in Specification **E2251**, may be used. In addition, thermometric devices such as resistance temperature detectors (RTDs), thermistors or thermocouples of equal or better accuracy may be used.

5.8 *Psychrometer*—Thermometers graduated in 0.2°F (0.1°C).

5.9 *Voltage-Regulator System*, to control the input voltage to the vacuum cleaner. The regulator system shall be capable of maintaining the vacuum cleaner's rated voltage $\pm 1\%$ and rated frequency having a wave form that is essentially sinusoidal with 3% maximum harmonic distortion for the duration of the test.

6. Sampling

6.1 A minimum of three units of the same model vacuum cleaner, selected at random in accordance with good statistical practice, shall constitute the population sample.

6.1.1 To determine the best estimate of maximum air power for the population of the vacuum cleaner model being tested, the arithmetic mean of the maximum air power of the sample from the population shall be established by testing it to a 90% confidence level within $\pm 5\%$.

6.1.2 **Annex A2** provides a procedural example for determining the 90% confidence level and when the sample size shall be increased (see **Note 2**).

NOTE 2—See **Annex A2** for method of determining 90% confidence level.

7. Test Vacuum Cleaners

7.1 *New Test Vacuum Cleaners:*

7.1.1 *Preconditioning a New Test Vacuum Cleaner*—Run the vacuum cleaner in at rated voltage $\pm 1\%$ and rated frequency with filters in place.

7.1.1.1 *Preconditioning a Rotating Agitator Type Vacuum Cleaner*—In a stationary position, operate the vacuum cleaner for 1 h with the agitator bristles not engaged on any surface.

7.1.1.2 *Preconditioning a Straight-Air Canister Vacuum Cleaner*—Operate the vacuum cleaner for 1 h with a wide-open inlet (without hose).

7.2 *Used Test Vacuum Cleaners:*

7.2.1 Recondition a used test vacuum cleaner; prior to the initial test run as follows:

7.2.1.1 Thoroughly remove excess dirt from the vacuum cleaner. Without using tools for disassembly, clean the entire outer surface, brushes, nozzle chamber, ductwork, inside of the chamber surrounding the primary filter, and inside hose and wands.

7.2.1.2 For vacuum cleaners using disposable filters as the primary filters, use a new disposable primary filter from the manufacturer for each test. Install it as recommended by the vacuum cleaner manufacturer.

7.2.1.3 For vacuum cleaners using water as the primary filter, empty the receptacle and refill as recommended by the manufacturer.

7.2.1.4 For vacuum cleaners using non-disposable dirt receptacles, empty in accordance with the manufacturer's instructions and clean the receptacle until its weight is within 0.07 oz (2 g) of its original weight and install it as recommended by the vacuum cleaner manufacturer.

NOTE 3—It is preferable to conduct this test method on new test vacuum cleaners prior to any other ASTM test methods to avoid contamination that could cause performance variations.

7.3 *Test Vacuum Cleaner Settings*—If various settings are provided, set the motor speed setting or suction regulator using the manufacturer's specifications as provided in the instruction manual for normal operation. If a different setting is used, make a note of the deviation in the test report.

8. Procedure

8.1 *Preparation for Test:*

8.1.1 Prepare the test vacuum cleaner(s) in accordance with Section 7.

8.1.2 Set the manometers to zero and check all instruments for proper operation.

8.1.3 Record the test station pressure and the dry-bulb and wet-bulb temperature readings within 6 ft (1.8 m) of the test area. Read the barometric pressure to the nearest 0.02 in. of mercury (0.51 mm of mercury), and the dry-bulb and wet-bulb temperatures to the nearest 0.2°F (or 0.1°C)

8.1.3.1 The test area shall be free of major fluctuating temperature conditions due to air conditioners or air drafts that would be indicated by a thermometer at the immediate test area.

8.1.4 Connect a manometer or equivalent instrument to the plenum chamber.

8.1.5 Connect a wattmeter and a voltmeter in accordance with power analyzer. Fig. 1.

8.1.5.1 *Wattmeter Correction*—If needed, the indication may be corrected for voltmeter and wattmeter potential coil loss by opening the load circuit on the load side of the wattmeter with the line voltage at the operating value. The wattmeter current connection may be at its most sensitive position. Subtract this loss value from the total load indication to obtain the true load. As an alternative method, use the following equation:

$$W_c = W_i - V^2/R_T \quad (1)$$

where:

- W_c = corrected wattage;
- W_i = indicated wattage;
- V = voltmeter reading; and
- R_T = $R_P \times R_V / (R_P + R_V)$;

where:

- R_T = total resistance, Ω ;
- R_P = wattmeter potential coil resistance, Ω , and
- R_V = voltmeter coil resistance, Ω .

8.2 *Setup—Attachment Hose:*

8.2.1 Connect the hose assembly to the plenum chamber hose adapter and seal only this connection. See Fig. 21.

8.2.1.1 The end of the hose assembly should be inserted inside the hose connector adapter and be perpendicular to the plenum chamber.

8.2.1.2 The end of the hose assembly shall not project into the plenum chamber.

8.2.2 The hose should be supported and kept straight and horizontal. Maintain the vacuum cleaner in its normal operating orientation. If the hose is not intended to enter the vacuum cleaner horizontally, gradually bend the hose with a single bend from the intake port to the plenum chamber. Any restraining method should allow the hose coupling to seal at the cleaner. See Fig. 32.

8.3 *Test Setup—Carpet Cleaning Mode:*

8.3.1 Mount the cleaner plate as shown in Fig. 1e of Specification F431 to the plenum chamber.

8.3.2 Make an adapter by any convenient method which adapts the test vacuum cleaner’s nozzle opening to the opening in the cleaner plate.

8.3.3 Maintain the largest cross-sectional area possible throughout the adapter. This will prevent impeding the airflow between the plenum chamber and the test vacuum cleaner’s nozzle.

8.3.4 It is recommended that the hole for the adapter/plenum chamber interface be located as close, if not directly below, the dirt pickup duct for the test vacuum cleaner’s nozzle.

8.3.5 The interface between the adapter and the test vacuum cleaner’s nozzle is to be airtight. This may be achieved by any convenient means.

8.3.6 If the vacuum cleaner incorporates edge cleaning slots along the side edge(s), or slots along the front and rear edge of the bottom plate, or both, these slots should be sealed by any convenient means such as clay, tape, and so forth.

8.3.7 Do not eliminate leaks resulting from test vacuum cleaner’s construction, except at the adapter/nozzle interface as described above.

8.3.8 An example of an adapter is shown in Fig. 43. This adapter uses a closed-cell foam gasket material or molded low durometer urethane material shaped to fit the contour of the test cleaner’s nozzle opening with sufficient surface area for sealing.

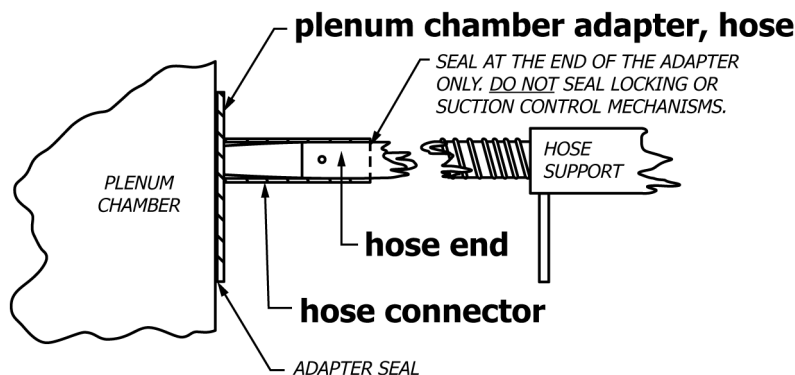

FIG. 21 Diagram of Hose and Adapter Connection

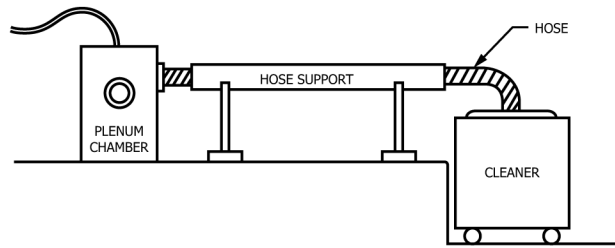

FIG. 32 Schematic for Air Performance Test

8.3.9 Attach the nozzle adapter to the plenum chamber’s cleaner plate, taking care to center the adapter’s opening over the hole in the cleaner plate.

8.3.10 The interface between the adapter and the plenum chamber should be airtight. The use of foam, clay, tape, or any other convenient means may be used to make this interface airtight.

8.3.11 Mount the test vacuum cleaner to the nozzle adapter by any convenient means.

8.3.12 The test vacuum cleaner, when mounted to the plenum chamber, should be set on the plenum chamber/adapter in the user position. If needed, the test vacuum cleaner’s rear wheels should be supported to keep the cleaner’s foot parallel with the plenum chamber’s surface.

8.3.13 For test cleaners incorporating a pivoting handle, support the test vacuum cleaner’s handle at 31.5 in. (800 mm) above the nozzle/adapter surface.

8.3.14 For those vacuum cleaners which have a non-pivoting handle, support the test vacuum cleaner’s handle at a height such that the cleaner’s nozzle is parallel to the surface of the nozzle adapter.

8.3.15 Secure the test vacuum cleaner to the plenum chamber to prevent the test vacuum from possibly moving and breaking the airtight seal during the test.

8.3.16 If the vacuum cleaner has a brush roll or other mechanism for agitating the floor surface during cleaning, it shall be activated for the duration of the test.

8.4 Test Procedure:

8.4.1 Any automatic bleed valve which affects the air performance of the vacuum cleaner shall not be defeated.

8.4.2 Operate the vacuum cleaner with no orifice plate inserted in the plenum chamber inlet at nameplate rated voltage $\pm 1\%$ and frequency ± 1 Hz prior to the start of the test run to allow the unit to reach its normal operating temperature. For vacuum cleaners with dual nameplate voltage ratings, conduct testing at the highest voltage. Do this before each test run.

8.4.3 The vacuum cleaner is to be operated at its nameplate rated voltage $\pm 1\%$ and frequency ± 1 Hz throughout the test. For vacuum cleaners with dual nameplate voltage ratings, conduct the test at the highest voltage.

8.4.3.1 Allow the vacuum cleaner to operate at the open orifice for 1 to 2 min between test runs.

8.4.4 While operating the vacuum cleaner per 8.4.3, insert orifice plates sequentially into the orifice plate holder of the plenum chamber starting with the largest size orifice and following it with the next smaller orifice plate. Use the following orifice plates: 2.000, 1.500, 1.250, 1.000, 0.875, 0.750, 0.625, 0.500, 0.375, 0.250, and 0 in. (50.8, 38.1, 31.7, 25.4, 22.2, 19.0, 15.8, 12.7, 9.5, and 6.3 mm). The following optional orifice plates may also be used: 2.500, 2.250, 1.750, 1.375, and 1.125 in. (63.5, 57.2, 44.5, 34.9, and 28.6 mm).

8.4.5 For each orifice plate, record the suction, h , and input power, P , in that order. All readings should be taken within 10 s of the orifice insertion. Allow the vacuum cleaner to operate at the open orifice for 1 to 2 min before inserting the next orifice.

8.4.5.1 Read the suction to the nearest graduation of the instrument. Readings should be taken as soon as the manometer reaches a true peak. (When using a fluid type manometer, the liquid level may peak, drop, and peak again. The second peak is the true peak reading. A person conducting the test for the first time shall observe at least one run before recording data. See Specification F431 for instructions on how to minimize the overshoot (first peak) of the liquid level.)

9. Calculation

9.1 Correction of Data to Standard Conditions:

9.1.1 Air Density Ratio—The density ratio, D_r , is the ratio of the air density at the time of test ρ_{test} , to the standard air density, $\rho_{\text{std}} = 0.075 \text{ lb/ft}^3$ (1.2014 kg/m^3). It is used to correct the vacuum and wattage readings to standard conditions. Find ρ_{test} (lb/ft^3 or kg/m^3) from standard psychometric charts or ASHRAE tables and calculate D_r as follows:

$$D_r = \frac{\rho_{\text{test}}}{\rho_{\text{std}}} \tag{1}$$

where:

- ρ_{test} = the air density at the time of test, lb/ft^3 , and
- ρ_{std} = the standard air density, 0.075 lb/ft^3 .

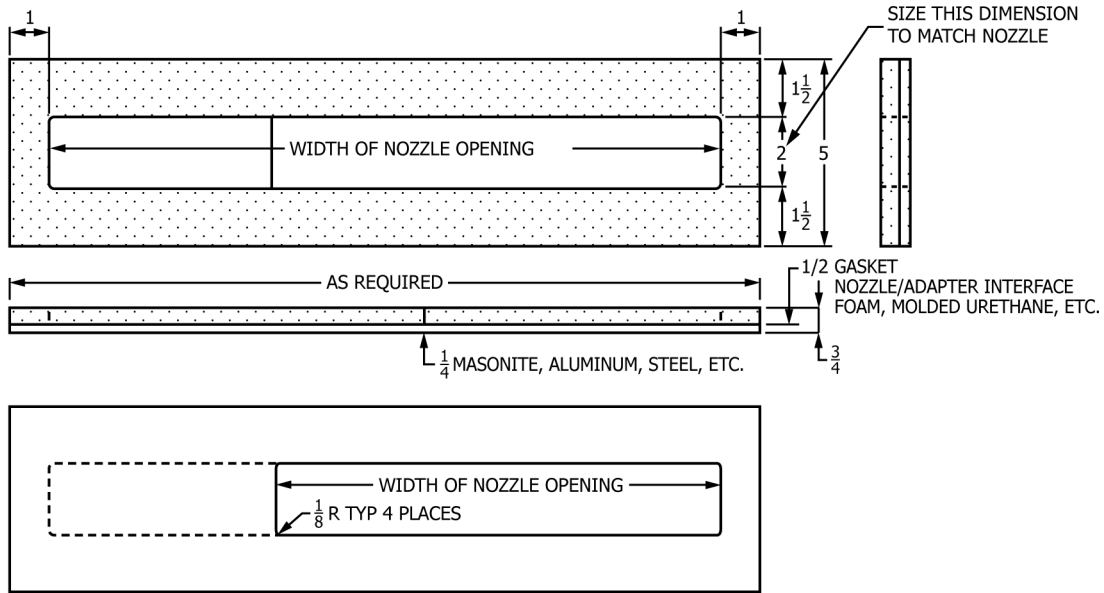

DIMENSIONS SHOWN ARE SUGGESTED AND SHOULD BE MODIFIED AS REQUIRED TO ACHIEVE A SATISFACTORY ADAPTER.

FIG. 43 Nozzle Adapter

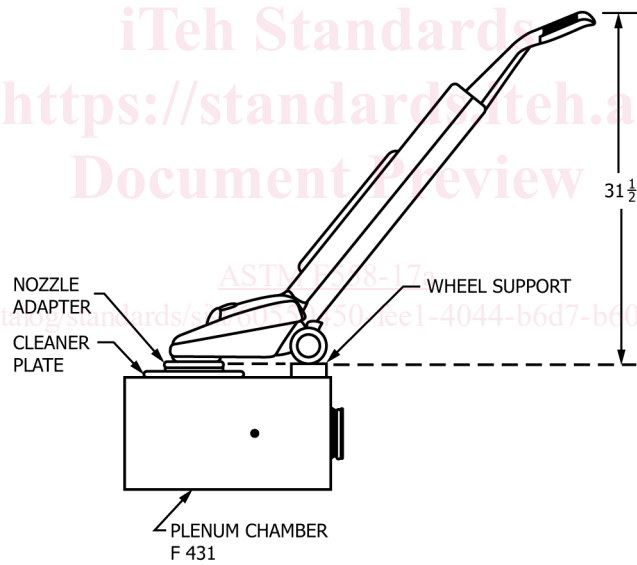

FIG. 54 Vacuum Cleaner Test Arrangement

ρ_{std} = the standard air density, 0.075 lb/ft³ (1.2014 kg/m³).

9.1.1.1 As an alternative, the following equation is intended to be used for correcting ambient conditions where the barometric pressure exceeds 27 in mercury and the dry-bulb and wet-bulb temperatures are less than 100°F (37.8°C); and may be used as an alternate method of calculating D_r (see Appendix X1 for derivation and accuracy analysis).

$$D_r = \frac{[17.68 B_t - 0.001978 T_w^2 + 0.1064 T_w + 0.0024575 B_t (T_d - T_w) - 2.741]}{T_d + 459.7}$$

where:

B_t = test station pressure at time of test, in. of mercury,

T_d = dry-bulb temperature at time of test, °F, and

T_w = wet-bulb temperature at time of test, °F.

9.1.2 Corrected Suction—Corrected suction, h_s , is the manometer reading, h , times the correction factor, C_s , as follows:

$$h_s = C_s h \quad (2)$$

9.1.2.1 For series universal motors (see Ref (6)) the correction factor, C_s , is calculated as follows:

$$C_s = 1 + 0.667(1 - D_r) \quad (3)$$

9.1.2.2 This test method does not have any formulas available for correcting input power for any other type of motor (permanent magnet, induction, etc.).

9.1.3 *Corrected Input Power*—Corrected input power, P_s , expressed in watts, is the wattmeter reading, P , times the correction factor, C_p , as follows:

$$P_s = C_p P \quad (4)$$

9.1.3.1 For series universal motors the correction factor, C_p , is calculated as follows:

$$C_p = 1 + 0.5(1 - D_r) \quad (5)$$

9.1.3.2 This test method does not have any formulas available for correcting input power for any other types of motor (permanent magnet, induction, etc.)

9.2 *Corrected Airflow*—Calculate the corrected airflow, Q , expressed in cubic feet per minute (see Note 4 and Appendix X2) as follows:

$$Q = 21.844 D^2 K_1 \sqrt{h_s} \quad (6)$$

where:

Q = corrected flow, cfm,

D = orifice diameter, in.,

K_1 = constant (dimensionless), orifice flow coefficients for orifices in the plenum chamber. See Table 1 for values for each orifice.

See Ref (1) for the derivation of these flow coefficients.

h_s = corrected suction, in. of water.

NOTE 4—For the corrected airflow expressed in liters per second, use the following equation:

$$Q = 10.309 D^2 K_1 \sqrt{h_s}$$

where:

Q = corrected flow, L/s,

D = orifice diameter, m,

K_1 = constant (dimensionless), and

h_s = corrected suction, Pa.

9.3 *Air Power*—Calculate the air power, AP , in watts, as follows:

$$AP = 0.117354 (Q)(h_s) \quad (7)$$

where:

AP = air power, W,

Q = corrected flow, cfm, and

h_s = corrected suction, inch of water.

NOTE 5—See Appendix X3 for derivation.

9.4 *Maximum Air Power*—Determine the maximum air power using the method in Annex A1.

10. Report

10.1 For each vacuum cleaner sample from the population being tested, report the following information:

10.1.1 Manufacturer's name and product model name or number, or both.

10.1.2 Type of cleaner; that is, upright, canister, etc.

10.1.3 The corrected input power, corrected vacuum, corrected airflow, and air power for each orifice used.

10.1.4 ~~Calculated~~ Measured or calculated maximum air power, whichever is greater.

10.1.5 Indicate the method of testing, end of hose or nozzle on plenum.

11. Precision and Bias⁶

11.1 The following precision statements are based on interlaboratory tests involving eight laboratories and four units.

11.2 The statistics have been calculated as recommended in Practice E691.

⁶ Complete data on the round-robin test is available from ASTM Headquarters. Request RR:F11-1010.

TABLE 1 Orifice Flow Coefficient Equations (K_1)

NOTE 1— K_1 was determined experimentally using an ASTM plenum chamber (see Specification F431) and an ASME flowmeter (see Ref (1)).

NOTE 2—Equations for K_1 in terms of B_t and h are given in Appendix X6.

Orifice Diameter, in. (mm)	Orifice Flow Coefficient Equation ^A
0.250 (6.3)	$K_1 = \frac{0.5575r - 0.5955}{r - 1.0468}$
0.375 (9.5)	$K_1 = \frac{0.5553r - 0.5754}{r - 1.0263}$
0.500 (12.7)	$K_1 = \frac{0.5694r - 0.5786}{r - 1.0138}$
0.625 (15.8)	$K_1 = \frac{0.5692r - 0.5767}{r - 1.0104}$
0.750 (19.0)	$K_1 = \frac{0.5715r - 0.5807}{r - 1.0138}$
0.875 (22.2)	$K_1 = \frac{0.5740r - 0.5841}{r - 1.0158}$
1.000 (25.4)	$K_1 = \frac{0.5687r - 0.5785}{r - 1.0146}$
1.125 (28.6)	$K_1 = \frac{0.5675r - 0.5819}{r - 1.0225}$
1.250 (31.7)	$K_1 = \frac{0.5717r - 0.5814}{r - 1.0152}$
1.375 (34.9)	$K_1 = \frac{0.5680r - 0.5826}{r - 1.0235}$
1.500 (38.1)	$K_1 = \frac{0.5719r - 0.5820}{r - 1.0165}$
1.750 (44.5)	$K_1 = \frac{0.5695r - 0.5839}{r - 1.0235}$
2.000 (50.8)	$K_1 = \frac{0.5757r - 0.5853}{r - 1.0157}$
2.250 (57.2)	$K_1 = \frac{0.5709r - 0.5878}{r - 1.0279}$
2.500 (63.5)	$K_1 = \frac{0.5660r - 0.59024}{r - 1.0400}$

^A

$$r = \frac{B_t (0.4912) - h(0.03607)}{B_t (0.4912)}$$

where:

B_t = test station pressure at time of test, in. of mercury, and
 h = uncorrected suction (manometer reading), in. of water.

TABLE 2 Repeatability and Reproducibility

Test Type	Coefficient of Variation, CV % _r	Repeatability Limit, r	Coefficient of Variation, CV % _R	Reproducibility Limit, R
End of Hose	2.190	6.132	6.533	18.292
Nozzle	4.795	13.426	19.265	53.942

11.3 The following statements regarding repeatability limit and reproducibility limit are used as directed in Practice E177.

11.4 The End of Hose Coefficients of Variation of repeatability and reproducibility of the measured results have been derived from nine sets of data, where each of two sets have been performed by a single analyst within each of the eight laboratories on separate days using the same test unit.⁶

11.5 The Nozzle Coefficients of Variation of repeatability and reproducibility of the measured results have been derived from seven sets of data, where each of two sets have been performed by a single analyst within each of the seven laboratories on separate days using the same test unit.⁶

11.6 *Repeatability (Single Operator and Laboratory, Multiday Testing)*—The ability of a single analyst to repeat the test within a single laboratory.

11.6.1 The expected coefficient of variation of the measured results within a laboratory, CV %_r, has been found to be the respective values listed in **Table 2**.

11.6.2 The 95 % repeatability limit within a laboratory, *r*, has been found to be the respective values listed in **Table 2**, where $r = 2.8 (CV \%_r)$.

11.6.3 With 95 % confidence, it can be stated that within a laboratory a set of measured results derived from testing a unit should be considered suspect if the difference between any two of the three values is greater than the respective value of the repeatability limit, *r*, listed in **Table 2**.

11.6.4 If the absolute value of the difference of any pair of measured results from three test runs performed within a single laboratory is not equal to or less than the respective repeatability limit listed in **Table 2**, that set of results shall be considered suspect.

11.7 *Reproducibility (Multiday Testing and Single Operator Within Multilaboratories)*—The ability to repeat the test within multiple laboratories.

11.7.1 The expected coefficient of variation of reproducibility of the average of a set of measured results between multiple laboratories, CV %_R, has been found to be the respective values listed in **Table 2**.

11.7.2 The 95 % reproducibility limit within a laboratory, *R*, has been found to be the respective values listed in **Table 2**, where $R = 2.8 (CV \%_R)$.

11.7.3 With 95 % confidence, it can be stated that the average of the measured results from a set of three test runs performed in one laboratory, as compared to a second laboratory, should be considered suspect if the difference between those two values is greater than the respective values of the reproducibility limit, *R*, listed in **Table 2**.

11.7.4 If the absolute value of the difference between the average of the measured results from the two laboratories is not equal to or less than the respective reproducibility limit listed in **Table 2**, the set of results from both laboratories shall be considered suspect.

11.8 *Bias*—No justifiable statement can be made on the accuracy of this test method for testing the properties listed. The true values of the properties cannot be established by acceptable referee methods.

12. Keywords

12.1 airflow; air performance; air power; suction; suction power; vacuum cleaner

ANNEXES

ASTM F558-17a (Mandatory Information)

A1. MATHEMATICAL METHOD FOR DETERMINING MAXIMUM AIR POWER POINT

A1.1 The following, second degree polynomial equation, is assumed to provide the best mathematical approximation of the air power versus airflow relationship.

NOTE A1.1—See Ref (4) for additional information.

$$Y = A_1 + A_2X + A_3X^2 \quad (A1.1)$$

where:

Y = air power (AP),
X = airflow (Q), and
*A*₁, *A*₂, and *A*₃, = arbitrary constants.

A1.1.1 Use *X* and *Y* values obtained from only five specific orifices selected as follows:

A1.1.1.1 Using the test data, determine the orifice size that produced the highest air power value.

A1.1.1.2 Use the air power and airflow values at this orifice, and the next two smaller and the next two larger orifices in the following computations:

A1.1.1.3 If the highest air power value calculated from the observed data is at the 2.0 in. (50.8 mm) orifice or larger, then use the air power and airflow values from the five largest orifices.

A1.2 To determine the values of A_1 , A_2 , and A_3 , use the X and Y values obtained from the five specified orifices and solve the following set of normalized equations:

$$\sum Y_i = NA_1 + A_2 \sum X_i + A_3 \sum X_i^2 \quad (\text{A1.2})$$

$$\sum X_i Y_i = A_1 \sum X_i + A_2 \sum X_i^2 + A_3 \sum X_i^3 \quad (\text{A1.3})$$

$$\sum X_i^2 Y_i = A_1 \sum X_i^2 + A_2 \sum X_i^3 + A_3 \sum X_i^4 \quad (\text{A1.4})$$

where:

N = 5 (number of orifices selected),

i = 1 to N , and

X_i and Y_i = the values obtained during testing ($X_1Y_1, X_2Y_2, \dots, X_NY_N$) at the five orifices specified in **A1.1.1**.

A1.3 Setting the derivative of **Eq A1.1** equal to zero and solving for X will determine the value of X_m where Y is at its maximum value $f(Y_{\max})$ as follows:

$$\frac{dy}{dx} = \frac{d}{dx} [A_1 + A_2X + A_3X^2] = 0 \quad (\text{A1.5})$$

$$\frac{dy}{dx} = A_2 + 2A_3X = 0$$

Substitute X_m as the value of X at Y_{\max} and solve for X_m : $Y_{\max} = A_1 + A_2X_m + A_3X_m^2$ (A1.7)

$$X_m = -\frac{A_2}{2A_3} \quad (\text{A1.6})$$

Substituting this value of X_m , and A_1 , A_2 , and A_3 , into **Eq A1.1** will determine the value of Y_{\max} (AP_{\max}) as follows:

ASTM F558-17a

<https://standards.iteh.ai/catalog/standards/sist/60550450-fee1-4044-b6d7-b60f455809c9/astm-f558-17a>

A1.4 Calculate the goodness of fit, R (correlation coefficient) as follows:

$$R = 1 - \frac{\sum (Y_{i \text{ OBS}} - Y_{i \text{ CAL}})^2}{\sum (Y_{i \text{ OBS}} - Y_{\text{OBS}})^2} \quad (\text{A1.8})$$

where:

$$Y_{i \text{ CAL}} = A_1 + A_2X_{i \text{ OBS}} + A_3X_{i \text{ OBS}}^2 \quad (\text{A1.9})$$

$$Y_{\text{OBS}} = \frac{1}{N} \sum Y_{i \text{ OBS}} \quad (\text{A1.10})$$

and:

and:

i = 1 to N orifices used in **8.2**,

OBS = observed data,

CAL = calculated data, and

$Y_{i \text{ OBS}}$ = is the air power (AP) obtained from the calculations in **9.3** for the corresponding value $X_{i \text{ OBS}}$ (airflow, Q) at any of the N orifices selected.

A1.4.1 If R is not greater than or equal to 0.900, the test must be performed again and the new set of data shall be used. If after repeating the test, the R value is still less than 0.9, the maximum measured or calculated value shall be reported.