



Designation: **D5404/D5404M – 12** D5404/D5404M – 12 (Reapproved 2017)

Standard Practice for Recovery of Asphalt from Solution Using the Rotary Evaporator¹

This standard is issued under the fixed designation D5404/D5404M; the number immediately following the designation indicates the year of original adoption or, in the case of revision, the year of last revision. A number in parentheses indicates the year of last reapproval. A superscript epsilon (ϵ) indicates an editorial change since the last revision or reapproval.

1. Scope

1.1 This practice is intended to recover asphalt from a solvent using the rotary evaporator to ensure that changes in the asphalt properties during the recovery process are minimized.

1.2 The values stated in either SI units or inch-pound units are to be regarded separately as standard. The values stated in each system may not be exact equivalents; therefore, each system shall be used independently of the other. Combining values from the two systems may result in ~~non-conformance~~ nonconformance with the standard.

1.2.1 Residual pressure measurements are shown in both the SI unit of kPa and the commonly used non-standard equivalent unit of “mm of Hg”.Hg.”

1.2.2 Measurements of volume and mass are only given in SI units because they are the only units typically used in practice when performing this standard practice.

1.3 *This standard does not purport to address all of the safety concerns, if any, associated with its use. It is the responsibility of the user of this standard to establish appropriate ~~safety~~ safety, health, and ~~health~~ environmental practices and determine the applicability of regulatory limitations prior to use.*

1.4 *This international standard was developed in accordance with internationally recognized principles on standardization established in the Decision on Principles for the Development of International Standards, Guides and Recommendations issued by the World Trade Organization Technical Barriers to Trade (TBT) Committee.*

2. Referenced Documents

2.1 *ASTM Standards:*²

D92 Test Method for Flash and Fire Points by Cleveland Open Cup Tester

D1856 Test Method for Recovery of Asphalt From Solution by Abson Method

D2939 Test Methods for Emulsified Bitumens Used as Protective Coatings (Withdrawn 2012)³

D3666 Specification for Minimum Requirements for Agencies Testing and Inspecting Road and Paving Materials

D6368 Specification for Vapor-Degreasing Solvents Based on *normal*-Propyl Bromide and Technical Grade *normal*-Propyl Bromide

3. Summary of Practice

3.1 The solution of solvent and asphalt from a prior extraction is distilled by partially immersing the rotating distillation flask of the rotary evaporator in a heated oil bath while the solution is subjected to a partial vacuum and a flow of nitrogen gas or carbon dioxide gas. The recovered asphalt can then be subjected to testing as required.

4. Significance and Use

4.1 In order to determine the characteristics of the asphalt in an asphalt paving mixture, it is necessary to extract the asphalt from the aggregate by means of a suitable solvent and then to recover the asphalt from the solvent without significantly changing

¹ This practice is under the jurisdiction of ASTM Committee D04 on Road and Paving Materials and is the direct responsibility of Subcommittee D04.25 on Analysis of Bituminous Asphalt Mixtures.

Current edition approved June 1, 2012 Oct. 1, 2017. Published May 2013 October 2017. Originally approved in 1997-1993. Last previous edition approved in 2011-2012 as D5404/D5404M – 11-12. DOI: 10.1520/D5404_D5404M-12.10.1520/D5404_D5404M-12R17.

² For referenced ASTM standards, visit the ASTM website, www.astm.org, or contact ASTM Customer Service at service@astm.org. For *Annual Book of ASTM Standards* volume information, refer to the standard's Document Summary page on the ASTM website.

³ The last approved version of this historical standard is referenced on www.astm.org.

the asphalt's properties. The asphalt recovered from the solvent by this practice can be tested using the same methods as for the original asphalt cement, and comparisons between the properties of the original and recovered asphalt can be made.

NOTE 1—The quality of the results produced by this standard are dependent on the competence of the personnel performing the procedure and the capability, calibration, and maintenance of the equipment used. Agencies that meet the criteria of Standard Practice Specification D3666 are generally considered capable of competent and objective testing/sampling/inspection/etc. Users of this standard are cautioned that compliance with Practice Specification D3666 alone does not completely assure reliable results. Reliable results depend on many factors; following the suggestions of Practice Specification D3666 or some similar acceptable guideline provides a means of evaluating and controlling some of those factors.

5. Apparatus

5.1 *Rotary Evaporator* (see Fig. 1), equipped with a distillation flask, a variable speed motor capable of rotating the distillation flask at a rate of at least 50 rpm, condenser, solvent recovery flask, and heated oil bath. The angle of the distillation flask from the horizontal to the bath is set at approximately 15°. The distillation flask (Note 2), when fully immersed, should be at a depth of approximately 40 mm [1.5 in.].

NOTE 2—A flask having a ~~2000 mL~~ 2000-mL capacity is recommended.

5.1.1 *Thermometric Device*—A built-in temperature measurement device capable of displaying the oil temperatures to the nearest $\pm 1^\circ\text{C}$ [$\pm 2^\circ\text{F}$].

5.2 *Manometer or Vacuum Gage*, suitable for measuring the specified vacuum.

5.3 *Gas Flowmeter*, capable of indicating a gas flow of up to 1000 mL/min.

5.4 *Sample Container*, having adequate volume to hold the sample and added solvent.

5.5 *Vacuum System*, capable of maintaining a vacuum to within ± 0.7 kPa [± 5 mm of Hg] of the desired level up to and including 80 kPa [600 mm of Hg].

5.6 *Oven*, capable of maintain a temperature of $165 \pm 5^\circ\text{C}$ [$329 \pm 10^\circ\text{F}$].

6. Reagents and Materials

6.1 *Nitrogen Gas or Carbon Dioxide Gas*—A pressurized tank with pressure-reducing valve, or other convenient source.

NOTE 3—Different flow rates may be required depending on whether nitrogen gas or carbon dioxide gas is used.

6.2 *Oil*—The oil for the heated oil bath should be USP White Oil or Silicone Fluid SWS-101 with flash point above 215°C [420°F] or an equivalent. The flash point is determined in accordance with Test Method D92.

6.3 *Solvents*:

6.3.1 *Trichloroethylene and Methylene Chloride*—The solvent for extracting the asphalt from mixtures should be reagent-grade reagent-grade trichloroethylene or methylene chloride. A technical grade of trichloroethylene may be used, but it is recommended that for each new supply of solvent, a blank should be run on an asphalt with known properties.

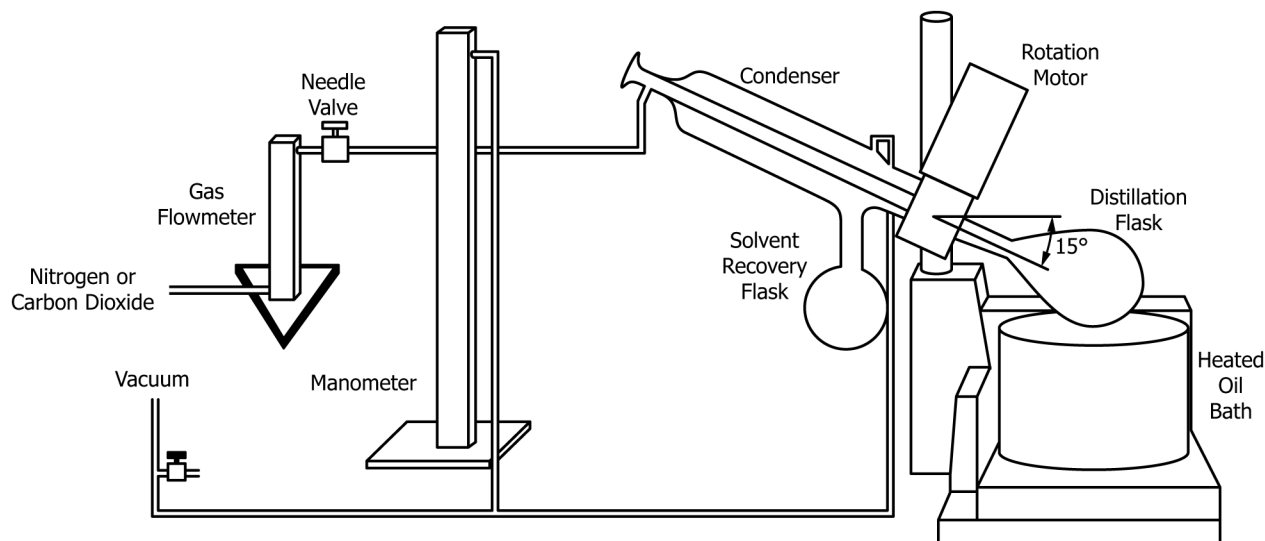

NOTE 1—It is important that the needle valve is located as shown instead of being placed ahead of the flowmeter.

FIG. 1 Rotary Evaporator and Recovery System