



Designation: **D7226 – 13 D7226 – 13 (Reapproved 2017)**

Standard Test Method for Determining the Viscosity of Emulsified Asphalts Using a Rotational Paddle Viscometer¹

This standard is issued under the fixed designation D7226; the number immediately following the designation indicates the year of original adoption or, in the case of revision, the year of last revision. A number in parentheses indicates the year of last reapproval. A superscript epsilon (ϵ) indicates an editorial change since the last revision or reapproval.

1. Scope

1.1 This test method utilizes the rotational paddle viscometer to measure the viscosity of emulsified asphalt. It is applicable to all the emulsified asphalts described in Specifications **D977** and **D2397**.

1.2 The values stated in SI units are to be regarded as standard. No other units of measurement are included in this standard.

1.3 *This standard does not purport to address all of the safety concerns, if any, associated with its use. It is the responsibility of the user of this standard to establish appropriate safety, health, and environmental practices and determine the applicability of regulatory limitations prior to use.*

1.4 *This international standard was developed in accordance with internationally recognized principles on standardization established in the Decision on Principles for the Development of International Standards, Guides and Recommendations issued by the World Trade Organization Technical Barriers to Trade (TBT) Committee.*

2. Referenced Documents

2.1 *ASTM Standards:*²

D140 Practice for Sampling Bituminous Materials

D977 Specification for Emulsified Asphalt

D2397 Specification for Cationic Emulsified Asphalt

E11 Specification for Woven Wire Test Sieve Cloth and Test Sieves

3. Terminology

3.1 *Definitions:*

3.1.1 *viscosity, n*—ratio of shear stress to shear rate. [M D7226-13\(2017\)](https://standards.iteh.ai/catalog/standards/sist/9a1df8e-6c84-4806-80a9-cdc785db190a/astm-d7226-132017)

<https://standards.iteh.ai/catalog/standards/sist/9a1df8e-6c84-4806-80a9-cdc785db190a/astm-d7226-132017>

¹ This test method is under the jurisdiction of ASTM Committee **D04** on Road and Paving Materials and is the direct responsibility of Subcommittee **D04.42** on Emulsified Asphalt Test.

Current edition approved Dec. 1, 2013; Oct. 1, 2017. Published January 2014; October 2017. Originally approved in 2006. Last previous edition approved in 2011 as **D7226 – 11; D7226 – 13**. DOI: 10.1520/D7226-13; 10.1520/D7226-13R17.

² For referenced ASTM standards, visit the ASTM website, www.astm.org, or contact ASTM Customer Service at service@astm.org. For *Annual Book of ASTM Standards* volume information, refer to the standard's Document Summary page on the ASTM website.

3.1.1.1 *Discussion*—

The SI unit of viscosity is the Pascal second (Pa·s).³

4. Summary of Test Method

4.1 The rotational paddle viscometer method is used to measure the apparent viscosity of emulsified asphalt at **50°C**, **25°C**, **50 °C**, **25 °C**, or other agreed-upon temperatures. A microprocessor circuitry system functioning in tandem with a temperature probe and equipped with internal electronic sensors detects and analyzes the preset temperature. A paddle is immersed in the emulsified asphalt sample and is rotated at **100 RPM**. The apparent viscosity of the sample is obtained and read from the electronic display or an optional printer.

³ The centimetre gram second (cgs) unit of viscosity is the poise (dynes/cm²) and is equivalent to 0.1 Pa·s. One centipoise (cP) is one millipascal second (mPa·s).

5. Significance and Use

5.1 The viscosity of emulsified asphalts characterizes their flow properties and affects their utility at 50°C or at other temperatures. The sprayability and workability of an emulsified asphalt are directly related to its viscosity for many applications. The material must be thin enough to be sprayed yet thick enough such that it will not flow from the crown or grade of the road. For ~~mixing grade~~ mixing-grade emulsified asphalts, the viscosity will affect its workability and resulting film thickness on the aggregate. This test method is useful to measure the apparent viscosity of emulsified asphalt at a temperature of 50°C, 25°C, 50 °C, 25 °C, or another agreed-upon temperature. The preset temperature and rotational speed at 100 RPMr/min allow for an automated and consistent determination of an emulsified asphalt viscosity within a short time.

6. Apparatus

6.1 The rotational paddle viscometer test system consists of a paddle, temperature probe, sample cup, the sample cup cover, a means of controlling the sample temperature to within $\pm 0.1^\circ\text{C} \pm 0.1^\circ\text{C}$, and a readout system to display viscosity. The dimensions of the sample cup and paddle are shown in Figs. 1-3.

6.2 *Thermometer*—Any thermometric device can be used to monitor the temperature of the sample being conditioned for testing.

6.3 *Sieve*—An 850- μm sieve or a 20-mesh strainer of wire cloth, framed or unframed, conforming to Specification E11 is used.

6.4 *Oven/Water Bath*—An oven/water bath capable of maintaining the required testing temperature within the limit of $\pm 3^\circ\text{C} \pm 3^\circ\text{C}$.

7. Hazards

7.1 **Warning**—Mercury has been designated by the EPA and many state agencies as a hazardous material that can cause central nervous system, kidney, and liver damage. Mercury, or its vapor, may be hazardous to health and corrosive to materials. Caution should be taken when handling mercury and ~~mercury-containing~~ mercury-containing products. See the applicable product Material Safety Data Sheet (MSDS) for details and the EPA’s website – <http://www.epa.gov/mercury/faq.htm> – for additional information. Users should be aware that selling mercury and/or ~~mercury-containing~~ mercury-containing products ~~into~~ in your state may be prohibited by state law.

8. Calibration and Standardization

8.1 Calibrate the rotational paddle viscometer at periodic intervals or as required by measuring the viscosity at 25°C of an appropriate standard following the procedure in Section 9.

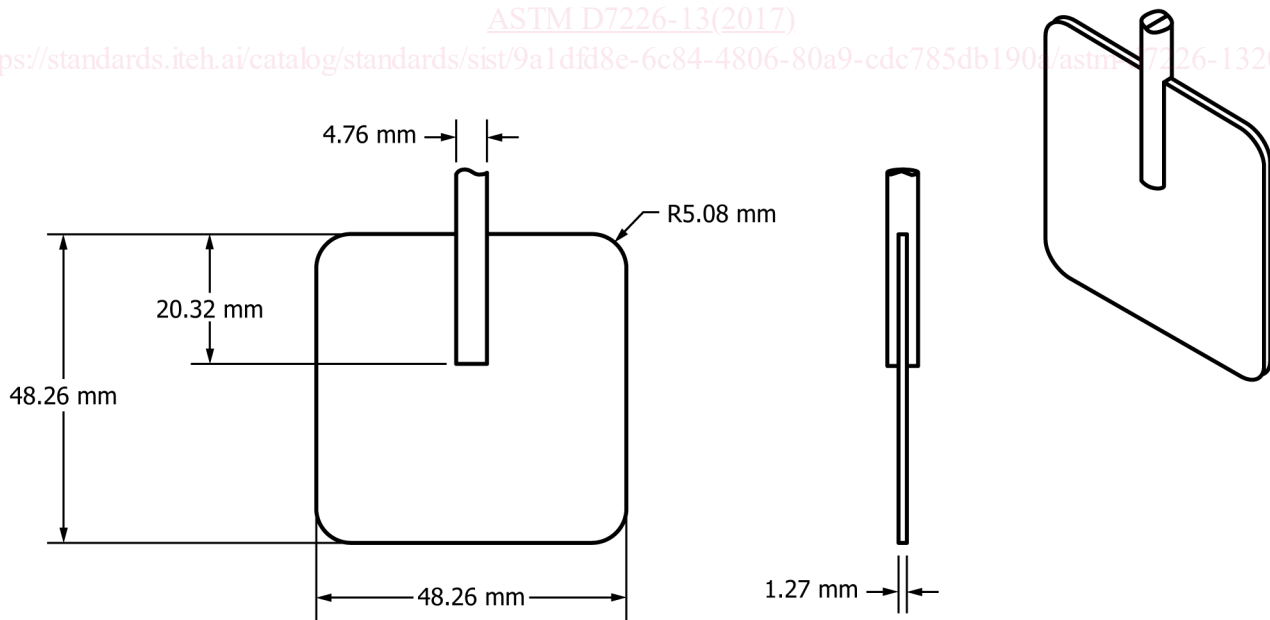

Tolerance $\pm .127$ mm

FIG. 1 Paddle Dimensions