



Designation: D8112 – 17

Standard Guide for Obtaining In-Service Samples of Turbine Operation Related Lubricating Fluid¹

This standard is issued under the fixed designation D8112; the number immediately following the designation indicates the year of original adoption or, in the case of revision, the year of last revision. A number in parentheses indicates the year of last reapproval. A superscript epsilon (ϵ) indicates an editorial change since the last revision or reapproval.

INTRODUCTION

Oil analysis is one of widely accepted condition monitoring techniques by the modern industry. This technology, however, depends on obtaining a representative sample of the fluid from the operating system. Although some information on sampling procedure for condition monitoring is provided in a number of different standards, there is a lack of a clear reference addressing all related issues in one document. The intent of this new standard is an attempt to provide all critical information related to fluid sampling for condition monitoring from steam and gas turbines as well as from other auxiliary equipment in power generating industry in one document.

1. Scope

1.1 This guide is applicable for collecting representative fluid samples for the effective condition monitoring of steam and gas turbine lubrication and generator cooling gas sealing systems in the power generation industry. In addition, this guide is also applicable for collecting representative samples from power generation auxiliary equipment including hydraulic systems.

1.2 The fluid may be used for lubrication of turbine-generator bearings and gears, for sealing generator cooling gas as well as a hydraulic fluid for the control system. The fluid is typically supplied by dedicated pumps to different points in the system from a common or separate reservoirs. Some large steam turbine lubrication systems may also have a separate high pressure pump to allow generation of a hydrostatic fluid film for the most heavily loaded bearings prior to rotation. For some components, the lubricating fluid may be provided in the form of splashing formed by the system components moving through fluid surfaces at atmospheric pressure.

1.3 Turbine lubrication and hydraulic systems are primarily lubricated with petroleum based fluids but occasionally also use synthetic fluids.

1.4 For large lubrication and hydraulic turbine systems, it may be beneficial to extract multiple samples from different locations for determining the condition of a specific component.

1.5 The values stated in SI units are regarded as standard.

1.5.1 The values given in parentheses are for information only.

1.6 *This standard does not purport to address all of the safety concerns, if any, associated with its use. It is the responsibility of the user of this standard to establish appropriate safety, health, and environmental practices and determine the applicability of regulatory limitations prior to use.*

1.7 *This international standard was developed in accordance with internationally recognized principles on standardization established in the Decision on Principles for the Development of International Standards, Guides and Recommendations issued by the World Trade Organization Technical Barriers to Trade (TBT) Committee.*

2. Referenced Documents

2.1 *ASTM Standards:*²

[B117 Practice for Operating Salt Spray \(Fog\) Apparatus](#)

[D923 Practices for Sampling Electrical Insulating Liquids](#)

[D3326 Practice for Preparation of Samples for Identification of Waterborne Oils](#)

[D4057 Practice for Manual Sampling of Petroleum and Petroleum Products](#)

[D4175 Terminology Relating to Petroleum Products, Liquid Fuels, and Lubricants](#)

[D4289 Test Method for Elastomer Compatibility of Lubricating Greases and Fluids](#)

¹ This guide is under the jurisdiction of ASTM Committee D02 on Petroleum Products, Liquid Fuels, and Lubricants and is the direct responsibility of Subcommittee D02.C0.01 on Turbine Oil Monitoring, Problems and Systems.

Current edition approved Oct. 1, 2017. Published October 2017. DOI: 10.1520/D8112-17.

² For referenced ASTM standards, visit the ASTM website, www.astm.org, or contact ASTM Customer Service at service@astm.org. For *Annual Book of ASTM Standards* volume information, refer to the standard's Document Summary page on the ASTM website.

- D4378** Practice for In-Service Monitoring of Mineral Turbine Oils for Steam, Gas, and Combined Cycle Turbines
- D6224** Practice for In-Service Monitoring of Lubricating Oil for Auxiliary Power Plant Equipment
- D7464** Practice for Manual Sampling of Liquid Fuels, Associated Materials and Fuel System Components for Microbiological Testing
- 2.2 *American National Standard Institute Standards:*³
- B93.19** Method for Extraction Fluid Samples from the Lines of an Operating Hydraulic Fluid Power System (for Particulate Contamination Analysis)
- B93.44** Method for Extracting Fluid Samples from the Reservoir of an Operating Hydraulic Fluid Power System
- 2.3 *ISO Standards:*³
- ISO 3165** Sampling of chemical products for industrial use—Safety in sampling
- ISO 3170** Petroleum Liquids—Manual Sampling
- ISO 4406** Hydraulic fluid power—Fluids—Method for coding the level of contamination by solid particles
- 2.4 *Society of Automotive Engineers Standards:*⁴
- SAE J517** Hydraulic Hose
- SAE J1273** Recommended Practices for Hydraulic Hose Assemblies

3. Terminology

3.1 For definitions of terms used in this guide, refer to Terminology **D4175**.

3.2 *Definitions of Terms Specific to This Standard:*

3.2.1 *bulk oil tote, n*—any container for lubrication or control fluid with working volume of approximately 1000 to 1300 L designed for fluid storage at atmospheric pressure.

3.2.2 *continuous sampling loop, n*—a limited flow of fluid from a point in a pressurized system to a point of lower pressure used to decrease required purge fluid and sample time during the sampling process.

3.2.3 *disposable sample tubing, n*—any single-use flexible plastic tubing used to transfer fluid during the sampling process.

3.2.4 *drain sampling, n*—a method of sampling used fluid for non-pressurized reservoirs or lines occurring when the lubricating fluid is being drained from the reservoir during a fluid change.

3.2.4.1 *Discussion*—As part of a fluid change, the drain plug is removed to allow the fluid to drain into an appropriate container under gravity. Mid way through the draining, a sample bottle is filled by placing it in the fluid stream and once filled immediately capped.

3.2.5 *drop tube sampling, n*—a method of sampling used fluid for non-pressurized reservoirs when sampling is completed by dropping an appropriate length of sampling tubing into the reservoir and using a vacuum generating device to extract the sample.

3.2.6 *permanent sample tube, n*—any tubing installed in a reservoir or pipe used to extract a sample from a specific location within the system.

3.2.7 *purge, v*—to remove the existing non-representative fluid and contaminants from the sample valve and tubing during the sampling process.

3.2.8 *reservoir, n*—any equipment-based container that holds a volume of fluid, usually under atmospheric condition, for use in the lubrication, sealing or control process.

3.2.9 *remote access hose, n*—any permanently installed metallic or elastomeric tube or hose used to transfer fluid from the system to a point outside the system to facilitate sampling.

3.2.10 *sample container, n*—a clean, fresh plastic bottle used for system fluid analysis (see section 6.1).

3.2.11 *sample valve, n*—a system consisting of a male and female component used specifically for the extraction of a fluid sample either by internal system pressure or by an externally generated vacuum.

3.2.11.1 *Discussion*—The male component, referred to as a probe, may be for one time use or permanently attached to the female component, referred to as a sample valve, is used by either threading the probe onto the valve or pushing the probe into the valve for the purpose of opening the valve and allowing fluid to flow out.

3.2.12 *sample valve sampling, v*—to obtain a sample from either pressurized or non pressurized lines or reservoirs.

3.2.12.1 *Discussion*—When sampling non-pressurized reservoirs this sampling method usually applies a vacuum generating device and sampling tubing to extract a sample into a sampling container from a strategically located sampling valve. When sampling pressurized reservoirs or lines, this sampling method is completed by using system pressure to force lubricating fluid into a sampling container through a sampling valve.

3.2.13 *vacuum generating device, n*—a pump used to create a low pressure in a sample container to cause fluid to move from a non-pressurized reservoir to the container through disposable tubing.

3.2.14 *weighted drop tube device, n*—a mass attached to a piece of steel or stainless steel tubing with a method to attach disposable sampling tubing to the steel or stainless steel tubing.

3.2.14.1 *Discussion*—This device is used during drop tube sampling.

4. Summary of Guide

4.1 This guide assists users in extracting representative in-service fluid samples from turbines and related lubrication and control systems primarily found in the power generation industry. This guide deals both with location of these sampling points and the method used to extract the sample.

4.2 There is great variation in the methods of sampling lubricating and control fluids in power generation turbines; however, most practices are based on the same principles. The same procedure should be used for each location on a piece of equipment. This is to provide sample consistency and improve sample repeatability, which is important for trending sample

³ Available from American National Standards Institute (ANSI), 25 W. 43rd St., 4th Floor, New York, NY 10036, <http://www.ansi.org>.

⁴ Available from SAE International (SAE), 400 Commonwealth Dr., Warrendale, PA 15096, <http://www.sae.org>.

results. This guide presents an example of a simplified lubrication system of a power generation turbine with potential primary and secondary sample locations for condition monitoring purposes.

4.3 Proper fluid sampling procedure must also focus on the safety of the person taking the sample.

4.4 In addition, the system safety should be maintained ensuring a minimum lubricant volume is maintained at all times.

4.5 It is also essential to prevent potential contamination of the sample by following the principles of this standard and proper procedure.

4.6 The fluid sampling process should also include proper sampling frequencies driven from failure mode and effect analysis to allow timely scheduling of corrective maintenance activities.

5. Significance and Use

5.1 Fluid analysis is one of the pillars in determining fluid and equipment conditions. The results of fluid analysis are used for planning corrective maintenance activities, if required.

5.2 The objective of a proper fluid sampling process is to obtain a representative fluid sample from critical location(s) that can provide information on both the equipment and the condition of the lubricant or hydraulic fluid.

5.3 The additional objective is to reduce the probability of outside contamination of the system and the fluid sample during the sampling process.

5.4 The intent of this guide is to help users in obtaining representative and repeatable fluid samples in a safe manner while preventing system and fluid sample contamination.

6. Apparatus Requirements

6.1 Requirements for Sample Container:

6.1.1 Unless specified otherwise by a laboratory, the sampling container should be a new and transparent container preferably constructed of clear polyethylene terephthalate. The sampling container should preferably be 125 mL (4 fluid ounces) or a multiple of this size. If large volumes are required, new, clean, high density polyethylene (HDPE) or polypropylene (PP) may be used. See Fig. 1.



FIG. 1 Examples of Typical Sample Bottles

6.1.2 For sampling phosphate ester fluids, the preferable sampling container should be one liter made from low density polyethylene (LDPE) or polypropylene (PP). For determining fluid cleanliness or for collecting high temperature samples, the recommended sample container material is borosilicate glass.

6.1.3 In the occasional event that gases in the fluid are required to be determined, the sampling container should be a new glass syringe with a three-way valve as outlined in Practice D923. This syringe and the three-way valve can be inserted as an intermediate device between the sampling valve and purge bottle as indicated in Fig. 2.

6.1.4 The sampling container should have a threaded upper portion. This is required for closing the cap and for attaching the sample bottle to the vacuum generating device used to extract the fluid sample.

6.1.5 The sampling container must hold a vacuum of 11.7 kPa absolute (1.7 psia) without collapsing and be appropriate for the fluid operating temperature.

6.1.6 Sampling containers should be supplied with the cap fully tightened. Sampling containers should be supplied with an average ISO cleanliness code of 9/7/4.

6.1.7 In dirty environments, the sampling bottle should be supplied in a clean resealable plastic bag. This arrangement allows the vacuum pump to be directly threaded to the bottle through the plastic bag then permitting the tubing to puncture the plastic membrane. This minimizes the possibility of external contamination entering the sample bottle. See Fig. 3.

6.1.8 Under no circumstance should sample containers be reused.

6.2 Requirement for Purging Bottle:

6.2.1 Typical purging bottle should be constructed of high density polyethylene (HDPE) or polypropylene (PP) of 500 mL (16 oz) capacity or more.

6.2.2 The neck of the purge bottle should have the same thread as the vacuum pump.

6.3 Requirement for Disposable Sample Tubing:

6.3.1 If tubing is required to move the fluid from the reservoir to the sample bottle it should be constructed of high density polyethylene (HDPE). Suggested sizes can be 4.7 mm outside diameter, 6.4 mm outside diameter or 7.9 mm outside diameter with a wall thickness of 1.5 mm. The sampling tubing must hold a vacuum of 11.7 kPa absolute (1.7 psia) without collapsing. Sampling tubing should be supplied in a fully sealed container and be used only for one sampling process after which it should be disposed of responsibly.

6.4 Requirements for Weighted Drop Tube Device:



FIG. 2 Example of a Dissolved Gas Device

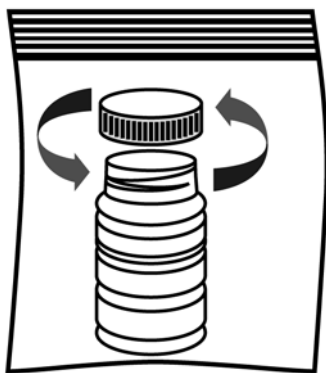

FIG. 3 Example of a Sampling Bottle in a Plastic Bag

6.4.1 Appropriate mass with an attached stainless steel tube with appropriately sized openings and a secure method to attach the disposable sample tubing. See Fig. 4.

6.5 Requirements for a Vacuum Generating Device:

6.5.1 The vacuum generating device is threaded to the sampling containers described in 6.1 and must generate a vacuum of 34 kPa absolute or greater in less than 30 s. The method of attaching the sampling tubing to the vacuum device must be in a way that does not allow the vacuum generating device to come in contact with the sampling fluid so that it remains clean and therefore can be used for multiple samples. Vacuum generating devices should be supplied and stored in a sealed container. The preferable material for the vacuum head is clear plastic (for example, acrylic). See Fig. 5.

6.6 Requirements for a Sample Valve:

6.6.1 Identification:

6.6.1.1 All sample valves must be identified with attached label, clearly displayed on the valve location.

6.6.1.2 The sample label should contain a unique sample valve identification number, and preferably sample type (primary or secondary) as well as what pressure is observed at the sample valve. The sample label should be constructed out of suitable permanent material, and permanently marked. See Fig. 6.

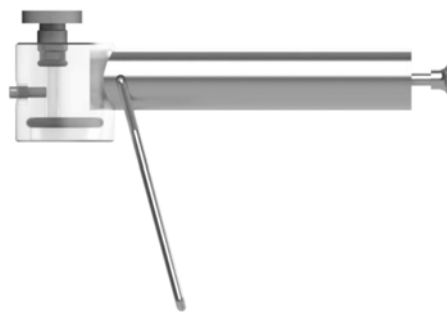

FIG. 5 Example of a Vacuum Generating Device

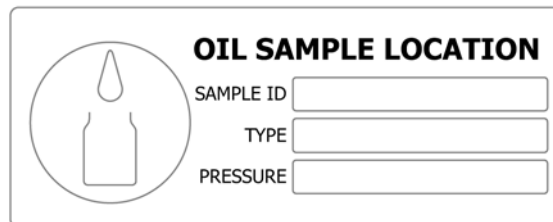

FIG. 6 Example of a Valve Label

6.6.2 Permanent Sample Tube:

6.6.2.1 The sample valve itself may have a length of tubing permanently attached that sits inside the reservoir allowing fluid to be repeatedly extracted from a specific point in the reservoir. Suggested sizes can be 4.7 mm outside diameter, 6.4 mm outside diameter or 7.9 mm outside diameter with a 0.71 mm minimum wall thickness. However, the exact dimension depends on the specific equipment design. The preferable material of the tubing should be stainless steel. Under most situations, stainless steel tubing should be selected to avoid any possible oxidation in the presence of free water. The joint must be mechanical in nature and fully compatible with the system fluid. It must withstand similar vacuum, pressure and temperature requirements as the sample valve.

6.6.2.2 A mechanical method to allow the sample tube to swivel is required to lock the sample tube into position without rotating the tube.

6.6.3 Non Pressurized Reservoir Sampling Valves:

6.6.3.1 Non pressurized reservoir sampling valves consist of a valve portion that is installed into the reservoir and a probe portion that attaches to the valve portion typically using a thread connection that is used in conjunction with a vacuum generating device. The valve may have a permanent sample tube attached to it. The probe may have a length of disposable sample tubing to move the vacuum generating device to a location to facilitate sampling.

6.6.3.2 The sample valve must have a protective cap covering the area where fluid exits the valve. The cap must be re-attached to the sample valve after sampling to assist in maintaining a clean environment and safe equipment operations.

6.6.3.3 The valve and probe system must hold a vacuum of 20 kPa absolute (3 psia) or greater over a 24 h period without the cap installed.

6.6.3.4 The purge volume for valve and tube system should preferably be at least three times of total volume of sampling

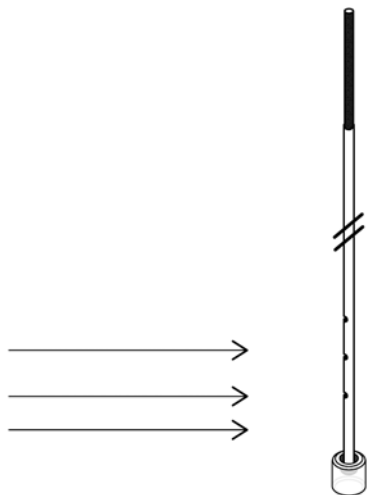

FIG. 4 Example of a Weighted Drop Tube Device

valve and tube. Care should be taken to avoid any critical depletion of lubricant in low volume applications.

6.6.3.5 The approximate flowrate for ISO 680 viscosity grade fluid at 40 °C when filling a 125 mL (4 oz) sample with 1200 mm of combined length of permanent and disposable sample tube would not exceed 4 minutes.

6.6.3.6 Upon disconnection of probe from sample valve no more than 0.25 mL of residue fluid should be left on the face of the valve, or within the non-sealed portion of the sample valve.

6.6.3.7 Sample valves must draw 2000 samples without failure of the valve. Non-pressurized reservoir sample valves must be able to pass a fluid that contains particulate of 500 µm in size. See Fig. 7.

6.6.3.8 For lubrication systems without original sampling ports, the user may consider modifying the existing drain or fluid level ports by retrofitting new valves having combined functions of fluid sampling valve, fluid level indicator, and fluid drain or addition capability. See Fig. 8.

6.6.4 Bulk Tote Sampling Valves:

6.6.4.1 This sampling valve consists of a valve and tube portion that is installed into the top of the bulk tote and a probe portion that attaches to the valve portion using a threaded connection that is used in conjunction with a vacuum generating device.

6.6.4.2 Alternatively, a weighted drop tube sampling device can be attached to the sample valve using flexible sample tubing and placed in the tote with the weight resting on the bottom of the tote.

6.6.5 Sampling Valves on Non-Pressurized Lines (Partially Flooded):

6.6.5.1 These sampling valves are located on non-pressurized, partially flooded lines, such as return lines from pressure lubricated bearings and are usually considered as secondary sampling valves used mainly for trouble-shooting.

6.6.5.2 In large turbine systems, these sampling valves may be located at return lines from critical bearings.

6.6.5.3 In addition to sampling valves located at each return line, some large turbine lubricating systems may contain additional sampling valves at the common, main return line. Usually the fluid sample is collected from this valve unless specific performance data such as temperature or vibration may indicate a problem at a specific bearing.

6.6.6 Sampling Valves on Pressurized Lines or Reservoirs:

6.6.6.1 For pressurized lines between 20 kPa and 5 MPa (3 psi to 750 psi), sampling valves can consist of a valve portion that has an integrated probe or a valve and probe system.

6.6.6.2 For pressurized lines above 5 MPa (750 psi), sampling valves must consist of a valve portion and a removable probe system. A fully enclosed probe and tubing system is required to direct fluid into the sample container. These sampling valves may have a tube permanently mounted inside the reservoir or line, allowing fluid to be repeatedly extracted from a specific point. The valve and probe system must withstand a pressure at least 4 times greater than the system pressure. The valve must hold a vacuum of 20 KPa absolute (3 psia) or greater over a 24 h period without the cap installed.

6.6.6.3 The sampling flow rate should allow collection of a 125 mL (4 oz) sample within approximately 60 s at system pressure.

6.6.6.4 The function of the sampling probe is to allow withdrawal of a representative portion of the fluid. Typical probe designs are provided in Practice D4057.

6.6.6.5 The sample valve and probe system needs to resist a minimum of 20 °C above operating temperature of the sampling fluid. Sampling valves must withstand a cyclical endurance test of 1.3 times the maximum system pressure for 1 million cycles without failure.

6.6.6.6 Sample valves also must draw 2000 samples at system pressure without failure.

6.6.6.7 Upon disconnection of the probe from the sample valve no more than 0.25 mL of residue fluid should be left on the face of the valve, or within the non-sealed portion of the sample valve.

6.6.6.8 For pressures below 1 MPa (145 psi), sample valves must pass fluid that contains particles of up to 500 µm.

6.6.6.9 For pressures above 1 MPa (145 psi), sample valves must be able to pass a fluid that contains particles up to 125 µm allowing particles to pass through in accordance with ISO cleanliness codes for fluid hydraulics (ISO 4406). See Fig. 9.

6.7 Fluid Compatibility:

6.7.1 Any materials used in the sample valve and probe must be compatible with the fluid with which it is being used. Elastomeric materials must meet Test Method D4289 requirements for compatibility with the fluid.

6.8 Temperature Rating:

6.8.1 The sample valve and probe system needs to meet a minimum requirement of 20 °C above the maximum temperature of the sampling fluid or outside environment, whichever is higher.

6.8.2 The sample valve and probe system must also meet a minimum requirement of 20 °C below the minimum operating temperature of the sampling fluid or outside environment, whichever is lower.

6.9 Corrosion Protection:

6.9.1 All sample valves and probes need to meet a minimum standard of 400 h to red rust corrosion test using Practice B117. In highly corrosive environments, sample valves should be constructed of suitable corrosion resistant materials.

6.10 Requirement for Remote Access Hose:



FIG. 7 Example of a Typical Fluid Sampling Valve with Stainless Steel Tub

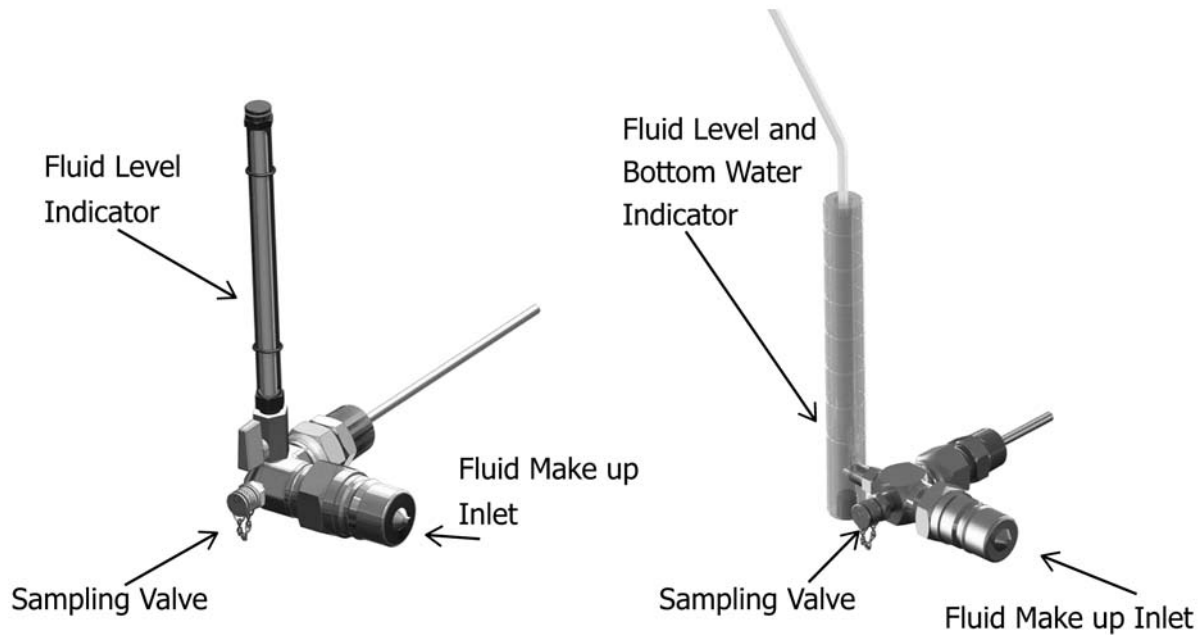

FIG. 8 Common Arrangements of Sampling Valve, Fluid Level Indicator and Fluid Make-up Inlet

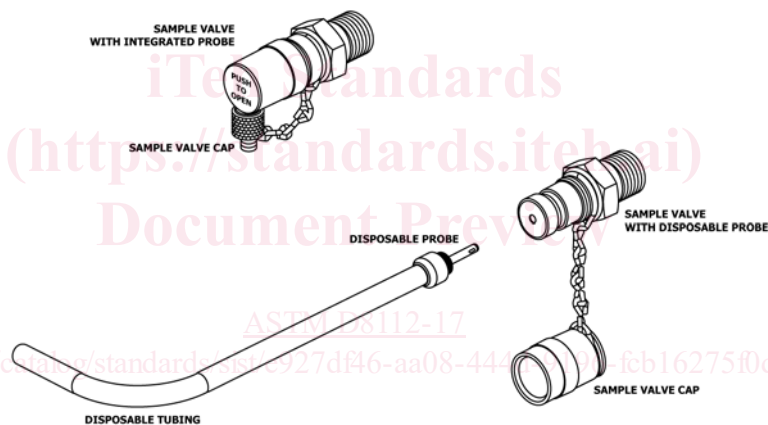

FIG. 9 Example of a Typical Sample Valve for Fluid under Pressure

6.10.1 Any hydraulic hose used for remote access installations must meet the SAE J517 specification based on temperature and pressure of the system fluid.

6.10.2 Elastomeric hose routings should follow recommendations found in SAE J517.

6.10.3 Elastomeric hose products must meet the temperature and fluid compatibility requirements as outlined in 6.7 Fluid Compatibility and 6.8 Temperature Rating.

6.10.4 The selection of the size of elastomeric hose should minimize the fluid purge volume. Typically, the inside diameter of the hose should not exceed size 5 diameter (approximately 0.8 mm or 5/16 in.).

7. Location of Sample Valve Installation

7.1 Turbine-generator lubrication and hydraulic control systems may have multiple sampling points from which a fluid sample may be extracted. It should be noted that sample fluid from a single location may not be representative of the condition of fluid and critical components in the entire system.

7.2 Sample valves from which fluid samples are regularly taken for condition monitoring are called primary sampling valves. Sample valves that are used non-routinely for specific purpose or for trouble shooting are called secondary sampling valves.

7.3 Selection of primary sampling valve locations depend on the types of physical and chemical properties required for condition monitoring. The sampling valve location may also be influenced by the design of the turbine systems, auxiliary equipment and available access. See Figs. 10-13.

7.4 Caution should be used when comparing fluid results from different sample valve locations. Also, samples should be taken in the same manner each time to allow reliable trending of fluid properties.

7.4.1 *Non-Pressurized Section of the Turbine Lubrication and Hydraulic Control System:*

7.4.1.1 For determining the presence of wear particles in the turbine lubrication, generator seal or governor control systems