



Designation: **D7137/D7137M—12 D7137/D7137M – 17**

## Standard Test Method for Compressive Residual Strength Properties of Damaged Polymer Matrix Composite Plates<sup>1</sup>

This standard is issued under the fixed designation D7137/D7137M; the number immediately following the designation indicates the year of original adoption or, in the case of revision, the year of last revision. A number in parentheses indicates the year of last reappraisal. A superscript epsilon ( $\epsilon$ ) indicates an editorial change since the last revision or reappraisal.

### 1. Scope

1.1 This test method covers compression residual strength properties of multidirectional polymer matrix composite laminated plates, which have been subjected to quasi-static indentation per Test Method **D6264/D6264M** or drop-weight impact per Test Method **D7136/D7136M** prior to application of compressive force. The composite material forms are limited to continuous-fiber reinforced polymer matrix composites with multidirectional fiber orientations, and which are both symmetric and balanced with respect to the test direction. The range of acceptable test laminates and thicknesses is defined in **8.2**.

NOTE 1—When used to determine the residual strength of drop-weight impacted plates, this test method is commonly referred to as the Compression After Impact, or CAI, method.

1.2 The method utilizes a flat, rectangular composite plate, previously subjected to a damaging event, which is tested under compressive loading using a stabilization fixture.

NOTE 2—The damage tolerance properties obtained are particular to the type, geometry and location of damage inflicted upon the plate.

1.3 The properties generated by this test method are highly dependent upon several factors, which include specimen geometry, layup, damage type, damage size, damage location, and boundary conditions. Thus, results are generally not scalable to other configurations, and are particular to the combination of geometric and physical conditions tested.

1.4 This test method can be used to test undamaged polymer matrix composite plates, but historically such tests have demonstrated a relatively high incidence of undesirable failure modes (such as end crushing). Test Method **D6641/D6641M** is recommended for obtaining compressive properties of undamaged polymer matrix composites.

1.5 The values stated in either SI units or inch-pound units are to be regarded separately as standard. The values stated in each system may not be exact equivalents; therefore, each system shall be used independently of the other. Combining values from the two systems may result in non-conformance with the standard.

1.5.1 Within the text the inch-pound units are shown in brackets.

1.6 *This standard does not purport to address all of the safety concerns, if any, associated with its use. It is the responsibility of the user of this standard to establish appropriate safety, health, and environmental practices and determine the applicability of regulatory limitations prior to use.*

1.7 *This international standard was developed in accordance with internationally recognized principles on standardization established in the Decision on Principles for the Development of International Standards, Guides and Recommendations issued by the World Trade Organization Technical Barriers to Trade (TBT) Committee.*

### 2. Referenced Documents

2.1 *ASTM Standards:*<sup>2</sup>

**D792** Test Methods for Density and Specific Gravity (Relative Density) of Plastics by Displacement

**D883** Terminology Relating to Plastics

**D3171** Test Methods for Constituent Content of Composite Materials

**D3878** Terminology for Composite Materials

**D5229/D5229M** Test Method for Moisture Absorption Properties and Equilibrium Conditioning of Polymer Matrix Composite Materials

<sup>1</sup> This test method is under the jurisdiction of ASTM Committee **D30** on Composite Materials and is the direct responsibility of Subcommittee **D30.05** on Structural Test Methods.

Current edition approved April 1, 2012; Oct. 15, 2017. Published May 2012; October 2017. Originally approved in 2005. Last previous edition approved in 2007 as D7137/D7137M-07-12. DOI: 10.1520/D7137-D7137M-12.10.1520/D7137\_D7137M-17.

<sup>2</sup> For referenced ASTM standards, visit the ASTM website, www.astm.org, or contact ASTM Customer Service at service@astm.org. For Annual Book of ASTM Standards volume information, refer to the standard's Document Summary page on the ASTM website.



- D5687/D5687M Guide for Preparation of Flat Composite Panels with Processing Guidelines for Specimen Preparation
- D6264/D6264M Test Method for Measuring the Damage Resistance of a Fiber-Reinforced Polymer-Matrix Composite to a Concentrated Quasi-Static Indentation Force
- D6641/D6641M Test Method for Compressive Properties of Polymer Matrix Composite Materials Using a Combined Loading Compression (CLC) Test Fixture
- D7136/D7136M Test Method for Measuring the Damage Resistance of a Fiber-Reinforced Polymer Matrix Composite to a Drop-Weight Impact Event
- E4 Practices for Force Verification of Testing Machines
- E6 Terminology Relating to Methods of Mechanical Testing
- E122 Practice for Calculating Sample Size to Estimate, With Specified Precision, the Average for a Characteristic of a Lot or Process
- E177 Practice for Use of the Terms Precision and Bias in ASTM Test Methods
- E456 Terminology Relating to Quality and Statistics
- ~~E1309 Guide for Identification of Fiber-Reinforced Polymer-Matrix Composite Materials in Databases (Withdrawn 2015)<sup>3</sup>~~
- ~~E1434 Guide for Recording Mechanical Test Data of Fiber-Reinforced Composite Materials in Databases (Withdrawn 2015)<sup>3</sup>~~
- 2.2 *Military Standards:*
- NASA Reference Publication 1092 Standard Tests for Toughened Resin Composites, Revised Edition, July 1983<sup>3</sup>

### 3. Terminology

3.1 *Definitions*—Terminology D3878 defines terms relating to composite materials. Terminology D883 defines terms relating to plastics. Terminology E6 defines terms relating to mechanical testing. Terminology E456 and Practice E177 define terms relating to statistics. In the event of a conflict between terms, Terminology D3878 shall have precedence over the other standards.

3.2 *Definitions of Terms Specific to This Standard:*

3.2.1 If the term represents a physical quantity, its analytical dimensions are stated immediately following the term (or letter symbol) in fundamental dimension form, using the following ASTM standard symbology for fundamental dimensions, shown within square brackets:  $[M]$  for mass,  $[L]$  for length,  $[T]$  for time,  $[\theta]$  for thermodynamic temperature, and  $[nd]$  for non-dimensional quantities. Use of these symbols is restricted to analytical dimensions when used with square brackets, as the symbols may have other definitions when used without the brackets.

3.2.2 *nominal value, n*—a value, existing in name only, assigned to a measurable property for the purpose of convenient designation. Tolerances may be applied to a nominal value to define an acceptable range for the property.

3.2.3 *principal material coordinate system, n*—a coordinate system with axes that are normal to the planes of symmetry inherent to a material.

ASTM D7137/D7137M-17

<sup>3</sup> Available from National Aeronautics and Space Administration (NASA)-Langley Research Center, Hampton, VA 23681-2199.  
<https://ntrs.nasa.gov/search?q=ASTM+D7137/D7137M-17&db=AS&term=ASTM+D7137/D7137M-17&start=1&size=10&sort=asc>

#### 3.2.3.1 Discussion—

Common usage, at least for Cartesian axes ( $123,xyz$ , and so forth), generally assigns the coordinate system axes to the normal directions of planes of symmetry in order that the highest property value in a normal direction (for elastic properties, the axis of greatest stiffness) would be 1 or  $x$ , and the lowest (if applicable) would be 3 or  $z$ . Anisotropic materials do not have a principal material coordinate system due to the total lack of symmetry, while, for isotropic materials, any coordinate system is a principal material coordinate system. In laminated composites, the principal material coordinate system has meaning only with respect to an individual orthotropic lamina. The related term for laminated composites is “reference coordinate system.”

3.2.4 *reference coordinate system, n*—a coordinate system for laminated composites used to define ply orientations. One of the reference coordinate system axes (normally the Cartesian  $x$ -axis) is designated the reference axis, assigned a position, and the ply principal axis of each ply in the laminate is referenced relative to the reference axis to define the ply orientation for that ply.

3.2.5 *specially orthotropic, adj*—a description of an orthotropic material as viewed in its principal material coordinate system. In laminated composites, a specially orthotropic laminate is a balanced and symmetric laminate of the  $[0_i/90_j]_{ns}$  family as viewed from the reference coordinate system, such that the membrane-bending coupling terms of the laminate constitutive relation are zero.

3.3 *Symbols:*  $A$  = cross-sectional area of a specimen

$CV$  = coefficient of variation statistic of a sample population for a given property (in percent)

$D$  = damage diameter

$E^{CAI}$  = effective compressive modulus in the test direction

$F^{CAI}$  = ultimate compressive residual strength in the test direction

$h$  = specimen thickness

$l$  = specimen length

$n$  = number of specimens per sample population

$N$  = number of plies in laminate under test

$P_{max}$  = maximum force carried by test specimen prior to failure

$S_{n-1}$  = standard deviation statistic of a sample population for a given property

$w$  = specimen width

$x_i$  = test result for an individual specimen from the sample population for a given property

$\bar{x}$  = mean or average (estimate of mean) of a sample population for a given property

#### 4. Summary of Test Method

4.1 A uniaxial compression test is performed using a balanced, symmetric laminated plate, which has been damaged and inspected prior to the application of compressive force. The damage state is imparted through out-of-plane loading caused by quasi-static indentation or drop-weight impact.

4.1.1 *Quasi-Static Indentation*—The rectangular plate is damaged due to application of an out-of-plane static indentation force in accordance with Test Method **D6264/D6264M**.

4.1.2 *Drop-Weight Impact*—The rectangular plate is damaged due to application of an out-of-plane drop-weight impact in accordance with Test Method **D7136/D7136M**.

4.2 The damaged plate is installed in a multi-piece support fixture, that has been aligned to minimize loading eccentricities and induced specimen bending. The specimen/fixture assembly is placed between flat platens and end-loaded under compressive force until failure. Applied force, crosshead displacement, and strain data are recorded while loading.

4.3 Preferred failure modes pass through the damage in the test specimen. However, acceptable failures may initiate away from the damage site, in instances when the damage produces a relatively low stress concentration or if the extent of damage is small, or both. Unacceptable failure modes are those related to load introduction by the support fixture, local edge support conditions, and specimen instability (unless the specimen is dimensionally representative of a particular structural application).

#### 5. Significance and Use

5.1 Susceptibility to damage from concentrated out-of-plane forces is one of the major design concerns of many structures made of advanced composite laminates. Knowledge of the damage resistance and damage tolerance properties of a laminated composite plate is useful for product development and material selection.

5.2 The residual strength data obtained using this test method is most commonly used in material specifications and research and development activities. The data are not intended for use in establishing design allowables, as the results are specific to the geometry and physical conditions tested and are generally not scalable to other configurations. Its usefulness in establishing quality assurance requirements is also limited, due to the inherent variability of induced damage, as well as the dependency of damage tolerance response upon the pre-existent damage state.

5.3 The properties obtained using this test method can provide guidance in regard to the anticipated damage tolerance capability of composite structures of similar material, thickness, stacking sequence, and so forth. However, it must be understood that the damage tolerance of a composite structure is highly dependent upon several factors including geometry, stiffness, support conditions, and so forth. Significant differences in the relationships between the existent damage state and the residual compressive

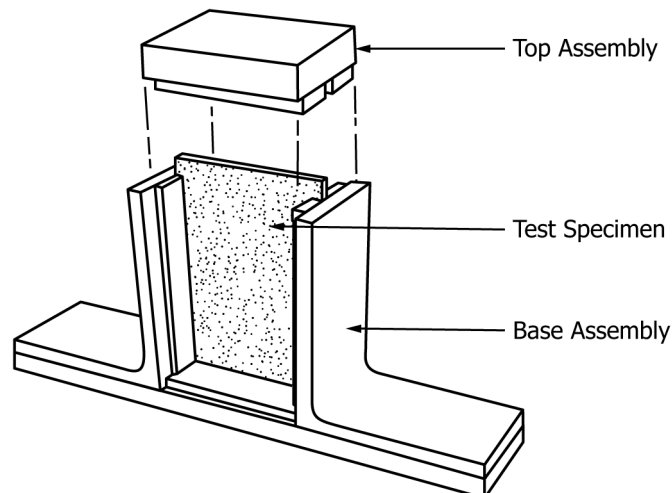

**FIG. 1 Schematic of Compressive Residual Strength Support Fixture with Specimen in Place**

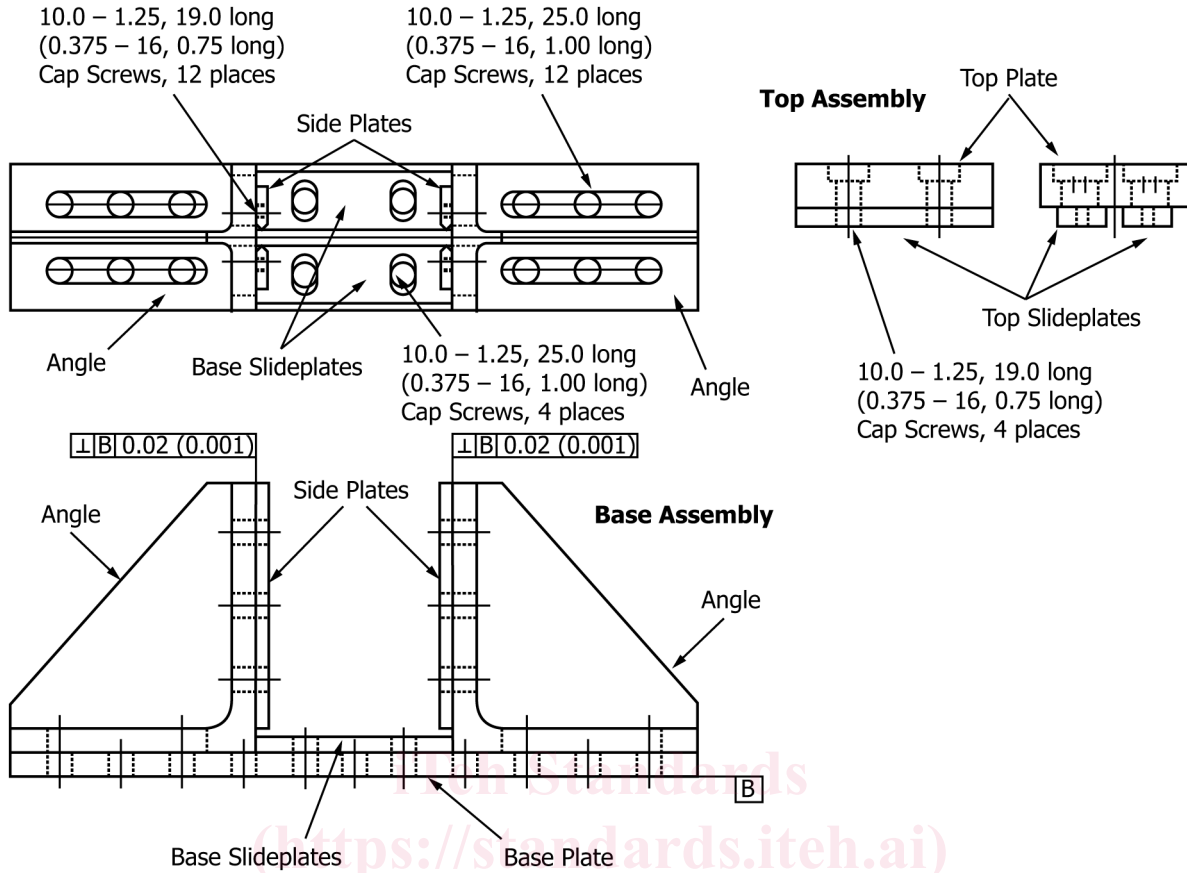

**Notes**

- 1) All dimensions in millimeters (inches) unless otherwise specified.
- 2) Dimensional tolerances are linear  $\pm 0.5$  mm ( $\pm 0.02$  in.), angular  $\pm 0.5$  degrees.
- 3) Break all edges.
- 4) Gussets on angles are optional but recommended.

**FIG. 2 Support Fixture Assembly**

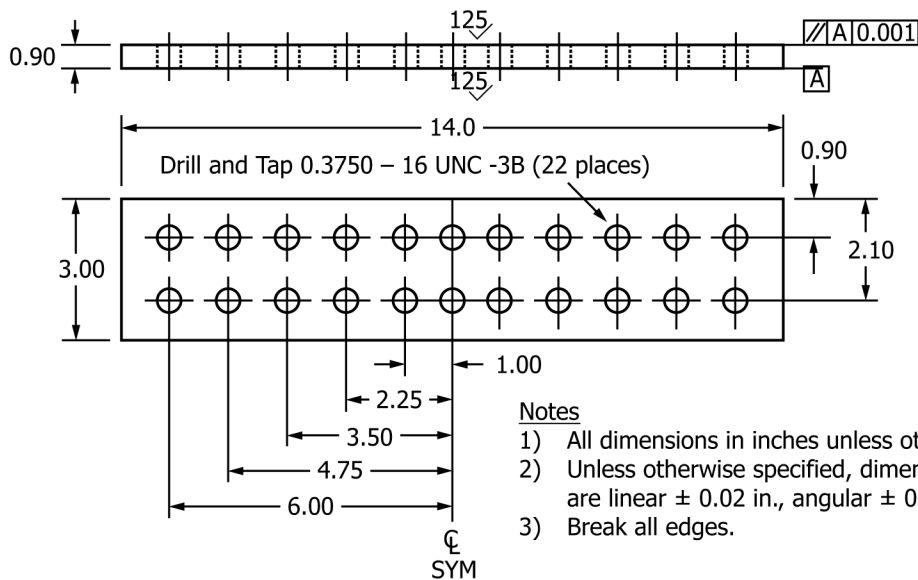

**FIG. 3 Support Fixture Base Plate (Inch-Pound Version)**

strength can result due to differences in these parameters. For example, residual strength and stiffness properties obtained using

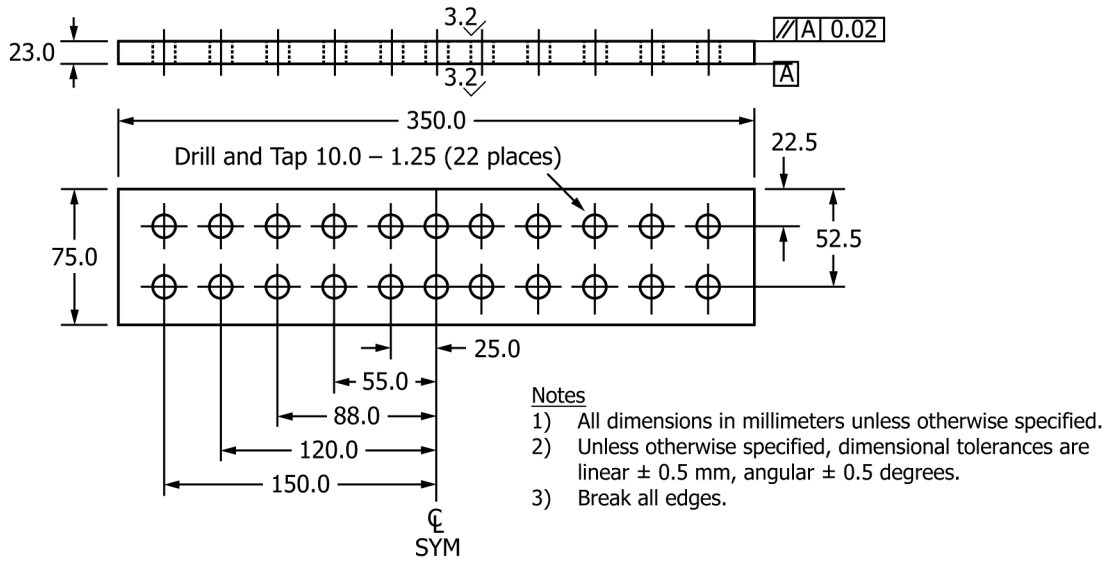

FIG. 4 Support Fixture Base Plate (SI Version)

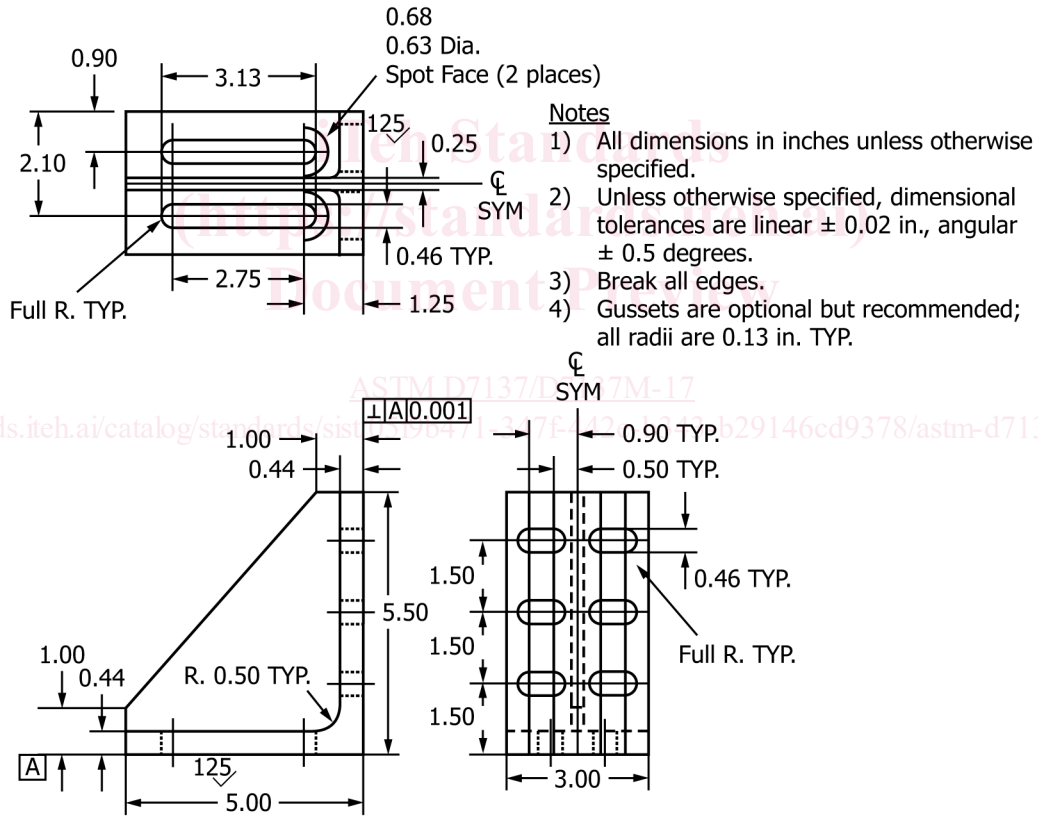

FIG. 5 Support Fixture Angles (Inch-Pound Version)

this test method would more likely reflect the damage tolerance characteristics of an un-stiffened monolithic skin or web than that of a skin attached to substructure which resists out-of-plane deformation. Similarly, test specimen properties would be expected to be similar to those of a panel with equivalent length and width dimensions, in comparison to those of a panel significantly larger than the test specimen.

5.4 The reporting section requires items that tend to influence residual compressive strength to be reported; these include the following: material, methods of material fabrication, accuracy of lay-up orientation, laminate stacking sequence and overall thickness, specimen geometry, specimen preparation, specimen conditioning, environment of testing, void content, volume percent

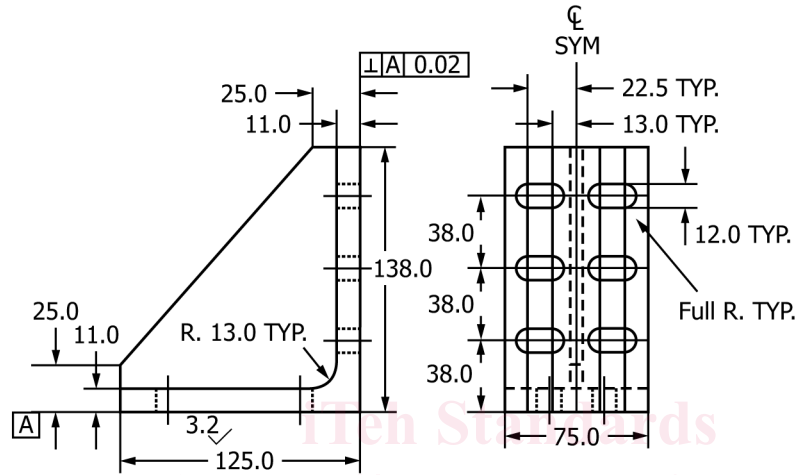
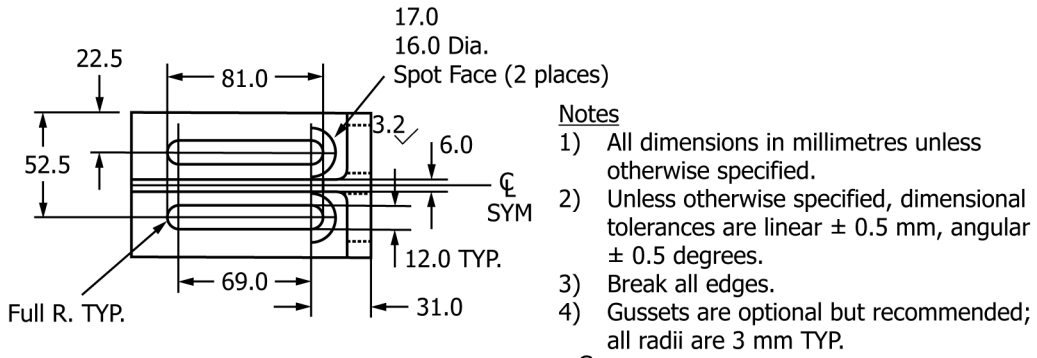
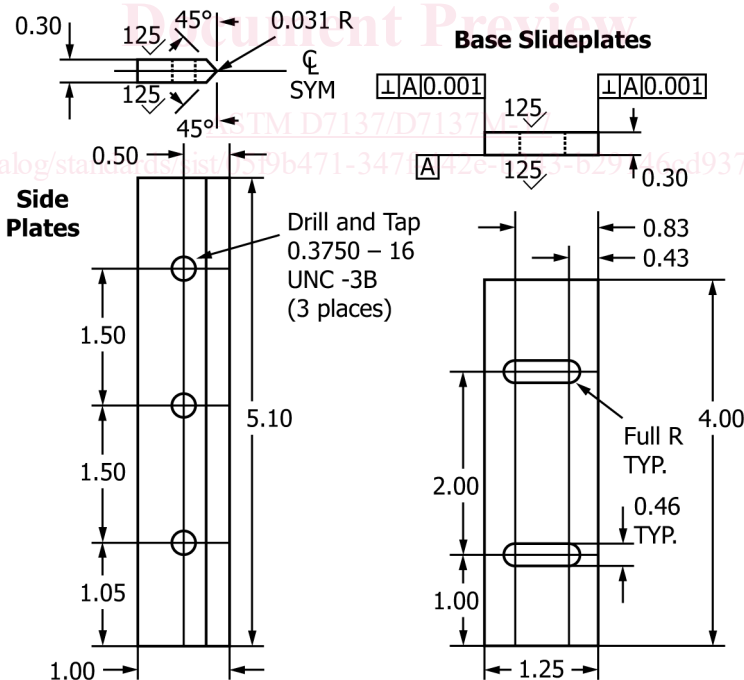

FIG. 6 Support Fixture Angles (SI Version)



**Notes**

- 1) All dimensions in inches unless otherwise specified.
- 2) Dimensional tolerances are linear  $\pm 0.02$  in., angular  $\pm 0.5$  degrees.
- 3) Break all edges.

FIG. 7 Support Fixture Side Plates and Base Slideplates (Inch-Pound Version)