



Designation: D5011 – 17

Standard Practices for Calibration of Ozone Monitors Using Transfer Standards¹

This standard is issued under the fixed designation D5011; the number immediately following the designation indicates the year of original adoption or, in the case of revision, the year of last revision. A number in parentheses indicates the year of last reapproval. A superscript epsilon (ϵ) indicates an editorial change since the last revision or reapproval.

1. Scope

1.1 These practices describe means for calibrating ambient, workplace or indoor ozone monitors, using transfer standards.

1.2 These practices describe five types of transfer standards:

Practice A—Analytical instruments,

Practice B—Boric acid potassium iodide (BAKI) manual analytical procedure,

Practice C—Gas phase titration with excess nitric oxide,

Practice D—Gas phase titration with excess ozone, and

Practice E—Ozone generator device.

1.3 These practices describe procedures to establish the authority of transfer standards: qualification, certification, and periodic recertification.

1.4 The values stated in SI units are to be regarded as standard. No other units of measurement are included in this standard.

1.5 *This standard does not purport to address all of the safety concerns, if any, associated with its use. It is the responsibility of the user of this standard to establish appropriate safety, health, and environmental practices and determine the applicability of regulatory limitations prior to use.* See Section 8 for specific precautionary statements.

1.6 *This international standard was developed in accordance with internationally recognized principles on standardization established in the Decision on Principles for the Development of International Standards, Guides and Recommendations issued by the World Trade Organization Technical Barriers to Trade (TBT) Committee.*

2. Referenced Documents

2.1 *ASTM Standards:*²

[D1071 Test Methods for Volumetric Measurement of Gaseous Fuel Samples](#)

¹ These practices are under the jurisdiction of ASTM Committee D22 on Air Quality and are the direct responsibility of Subcommittee D22.03 on Ambient Atmospheres and Source Emissions.

Current edition approved Oct. 1, 2017. Published October 2017. Originally approved in 1989. Last previous edition approved in 2009 as D5011 – 92 (2009). DOI: 10.1520/D5011-17.

² For referenced ASTM standards, visit the ASTM website, www.astm.org, or contact ASTM Customer Service at service@astm.org. For *Annual Book of ASTM Standards* volume information, refer to the standard's Document Summary page on the ASTM website.

[D1193 Specification for Reagent Water](#)

[D1356 Terminology Relating to Sampling and Analysis of Atmospheres](#)

[D3195 Practice for Rotameter Calibration](#)

[D3249 Practice for General Ambient Air Analyzer Procedures](#)

[D3631 Test Methods for Measuring Surface Atmospheric Pressure](#)

[D3824 Test Methods for Continuous Measurement of Oxides of Nitrogen in the Ambient or Workplace Atmosphere by the Chemiluminescent Method](#)

[D4230 Test Method of Measuring Humidity with Cooled-Surface Condensation \(Dew-Point\) Hygrometer](#)

[D5110 Practice for Calibration of Ozone Monitors and Certification of Ozone Transfer Standards Using Ultraviolet Photometry](#)

[E591 Practice for Safety and Health Requirements Relating to Occupational Exposure to Ozone \(Withdrawn 1990\)](#)³

2.2 *Other Documents:*

[40 CFR Part 50 Environmental Protection Agency Regulations on Ambient Air Monitoring Reference Methods](#)⁴

3. Terminology

3.1 *Definitions*—For definitions of terms used in this standard, see Terminology [D1356](#).

3.2 *Definitions of Terms Specific to This Standard:*

3.2.1 *primary standard, n*—a standard directly defined and established by some authority, against which all secondary standards are compared.

3.2.2 *secondary standard, n*—a standard used as a means of comparison, but checked against a primary standard.

3.2.3 *standard, n*—an accepted reference sample or device used for establishing measurement of a physical quantity.

3.2.4 *transfer standard, n*—a type of secondary standard. It is a transportable device or apparatus, which, together with operational procedures, is capable of reproducing pollutant concentration or producing acceptable assays of pollutant concentrations.

³ The last approved version of this historical standard is referenced on www.astm.org.

⁴ Available from U.S. Government Printing Office, Superintendent of Documents, 732 N. Capitol St., NW, Washington, DC 20401-0001, <http://www.access.gpo.gov>.

3.2.5 *zero air, n*—purified air that does not contain ozone and does not contain any other component that may interfere with the measurement. See 7.1.

3.3 Symbols:

b	= Spectrophotometer cell path length, cm. See Annex A2 .
d_{avg}	= Average of discrete single point comparisons. See Annex A1 .
d_i	= Single point comparison. See Annex A1 .
F_D	= Diluent air flow, mL/min.
$F_{D'}$	= New diluent air flow, mL/min.
F_{NO}	= NO flow, mL/min.
F_O	= Flow through the O ₃ generator, mL/min.
F_R	= Flowrate corrected to reference conditions (25°C and 101.3 kPa), mL/min. See Annex A2 .
F_S	= Flowrate at sampling conditions, mL/min. See Annex A2 .
F_T	= The total flow required at the output manifold (monitors demand plus 10 to 50 % excess), mL/min.
I	= The intensity of light which passes through the photometer absorption cell and is sensed by the detector when the cell contains an O ₃ sample. See Annex A4 .
$[I_2]_i$	= Concentration of each I ₂ standard, mol I ₂ /L. See Annex A2 .
I_{avg}	= Average intercept. See Annex A1 .
I_i	= Individual intercepts. See Annex A1 .
I_O	= The intensity of light which passes through the photometer absorption cell and is sensed by the detector when the cell contains zero air. See Annex A4 .
m_{avg}	= Average slope. See Annex A1 .
m_i	= Individual slopes. See Annex A1 .
$mol I_2$	= I ₂ released, mols. See Annex A2 .
N_{KIO_3}	= Normality of KIO ₃ , equivalent/L. See Annex A2 .
$[NO]$	= Diluted NO concentration, ppm. See Annex A4 .
$[NO]_{ORIG}$	= Original NO concentration, ppm. See Annex A3 .
$[NO]_{OUT}$	= Highest NO concentration required at the output manifold, ppm. It is approximately equal to 90 % of the upper range limit of the O ₃ concentration to be determined. See Annex A3 .
$[NO]_{RC}$	= NO concentration (approximate) in the reaction chamber, ppm. See Annex A3 .
$[NO]_{REM}$	= NO concentration remaining after addition of O ₃ , ppm. See Annex A3 .
$[NO]_{STD}$	= Concentration of the undiluted NO standard, ppm.
n	= Number of comparisons. See Eq 4 .
$[O_3]_{CERT}$	= Certified O ₃ concentration, ppm.
$[O_3]_{CERT'}$	= Diluted certified O ₃ concentration, ppm.
$[O_3]_{GEN}$	= O ₃ concentration produced by the O ₃ generator, ppm. See Annex A4 .
$[O_3]_{OUT}$	= Indicated O ₃ concentration, ppm. See Annex A2 .
$[O_3]_{OUT'}$	= Diluted O ₃ concentration, ppm.

$[O_3]_{RC}$	= O ₃ concentration (approximate) at the output manifold, ppm.
P_{H_2O}	= Vapor pressure of H ₂ O at T_S , kPa, wet volume standard. (For a dry standard, $P_{H_2O} = 0$.) (See Test Method D4230 for tables of saturation vapor pressure of water.) See Annex A2 .
P_R	= Dynamic specification, determined empirically, to ensure complete reaction of O ₃ or NO, ppm/min.
P_S	= Barometric pressure at sampling conditions, kPa. See Annex A2 .
S_c	= Slope of KI calibration curve, mL/mol/cm. See Annex A2 .
s_d	= Standard deviation of single point comparisons. See Annex A1 .
s_i	= Relative standard deviation of the six intercepts. See Annex A1 .
s_m	= Relative standard deviation of the six slopes. See Annex A1 .
t_R	= Residence time in reaction chamber, min.
t_s	= Sampling time, min. See Annex A2 .
T_S	= Temperature at sampling conditions, °C. See Annex A2 .
URL	= Upper range limit of O ₃ or NO monitor, ppm.
V_i	= Volume of I ₂ solution, mL. See Annex A2 .
V_{O_3}	= Volume of O ₃ absorbed, μL. See Annex A2 .
V_R	= Volume of air sampled, corrected to 25°C and 101.3 kPa, mL. See Annex A2 .
V_{RC}	= Volume of the reaction chamber, mL.
y_i	= O ₃ concentration indicated by the transfer standard, ppm. See 10.7.2 .
Z	= Recorder response with zero air, % scale.

4. Summary of Practices

4.1 These practices describe the procedures necessary to establish the authority of ozone transfer standards: qualification, certification, and periodic recertification. Qualification consists of demonstrating that a candidate transfer standard is sufficiently stable (repeatable) to be useful as a transfer standard. Repeatability is necessary over a range of variables (such as temperature, line voltage, barometric pressure, elapsed time, operator adjustments, relocation, etc.), any of which may be encountered during use of the transfer standard. Tests and possible compensation techniques for several such common variables are described. Detailed certification procedures are provided, and the quantitative specifications necessary to maintain continuous certification of the transfer standard are also provided.

4.2 *Practice A*—A dedicated ozone monitor is tested as described in [4.1](#) to demonstrate its authority as a transfer standard.

4.3 *Practice B*—This procedure (**1**)⁵ is based on the reaction between ozone (O₃) and potassium iodide (KI) to release iodine (I₂) in accordance with the following stoichiometric equation (**2**):

⁵ The boldface numbers in parentheses refer to a list of references at the end of this standard.

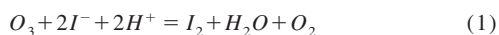

The stoichiometry is such that the amount of I_2 released is equal to the amount of O_3 absorbed. Ozone is absorbed in a 0.1 N boric acid solution containing 1 % KI, and the I_2 released reacts with excess iodide ion (I^-) to form triiodide ion (I_3^-), which is measured spectrophotometrically at a wavelength of 352 nm. The output of a stable O_3 generator is assayed in this manner, and the O_3 generator is immediately used to calibrate the O_3 monitor.

4.4 *Practice C*—This procedure is based on the rapid gas phase reaction between nitric oxide (NO) and O_3 , as described by the following equation (3):



When O_3 is added to excess NO in a dynamic system, the decrease in NO response is equivalent to the concentration of O_3 added. The NO is obtained from a standard NO cylinder, and the O_3 is produced by a stable O_3 generator. A chemiluminescence NO analyzer is used to measure the change in NO concentration. The concentration of O_3 added may be varied to obtain calibration concentrations over the range desired. The dynamic system is designed to produce locally high concentrations of NO and O_3 in the reaction chamber, with subsequent dilution, to effect complete O_3 reaction with relatively small chamber volumes.

4.5 *Practice D*—This procedure is based on the rapid gas phase reaction between O_3 and nitric oxide (NO) as described by the following equation (3):



When NO is added to excess O_3 in a dynamic system, the decrease in O_3 response observed on an uncalibrated O_3 monitor is equivalent to the concentration of NO added. By measuring this decrease in response and the initial response, the O_3 concentration can be determined. Additional O_3 concentrations are generated by dilution. The gas phase titration (GPT) system is used under predetermined flow conditions to insure that the reaction of NO is complete and that further reaction of the resultant nitrogen dioxide (NO_2) with residual O_3 is negligible.

4.6 *Practice E*—A dedicated ozone generator is tested as described in 4.1 to demonstrate its authority as a transfer standard.

5. Significance and Use

5.1 The reactivity and instability of O_3 precludes the storage of O_3 concentration standards for any practical length of time, and precludes direct certification of O_3 concentrations as SRM's. Moreover, there is no available SRM that can be readily and directly adapted to the generation of O_3 standards analogous to permeation devices and standard gas cylinders for sulfur dioxide and nitrogen oxides. Dynamic generation of O_3 concentrations is relatively easy with a source of ultraviolet (UV) radiation. However, accurately certifying an O_3 concentration as a primary standard requires assay of the concentration by a comprehensively specified analytical procedure, which must be performed every time a standard is needed.

5.2 The primary UV standard photometers, which are usually used at a fixed location under controlled conditions, are used to certify transfer standards that are then transported to the field sites where the ambient ozone monitors are being used. See Practice D5110.

5.3 The advantages of this procedure are:

5.3.1 All O_3 monitors in a given network or region may be traced to a single primary standard.

5.3.2 The primary standard is used at only one location, under controlled conditions.

5.3.3 Transfer standards are more rugged and more easily portable than primary standards.

5.3.4 Transfer standards may be used to intercompare various primary standards.

6. Apparatus

6.1 *Apparatus Common to Practices A Through E:*

6.1.1 UV Photometric calibration system, as shown in Fig. 1, consisting of the following:

6.1.1.1 *Primary Ozone Standard*, a UV photometer, consisting of a low-pressure mercury discharge lamp, collimation optics (optional), an absorption cell, a detector, and signal-processing electronics. It shall be capable of measuring the transmittance, I/I_0 , at a wavelength of 253.7 nm with sufficient precision that the standard deviation of the concentration measurements does not exceed the greater of 0.005 ppm or 3 % of the concentration. It shall incorporate means to assure that no O_3 is generated in the cell by the UV lamp. This is generally accomplished by filtering out the 184.9 nm Hg line with a high silica filter. In addition, at least 99.5 % of the radiation sensed by the detector shall be 253.7 nm. This is usually accomplished by using a solar blind photodiode tube. The length of the light path through the absorption cell shall be known with an accuracy within at least 99.5 %. In addition the cell and associated plumbing shall be designed to minimize loss of O_3 from contact with surfaces (4). See Practice D5110.

6.1.1.2 *Air Flow Controller*, capable of regulating air flows as necessary to meet the output stability and photometer precision requirements.

6.1.1.3 *Flowmeters*, calibrated in accordance with Practice D3195.

6.1.1.4 *Ozone Generator*, capable of generating stable levels of O_3 over the required concentration range. It shall be stable over short periods to allow for stability of the monitor or transfer standard connected to the output manifold. Conventional UV-photolytic type generators may be adequate but shall have line voltage and temperature regulation.

6.1.1.5 *Output Manifold*, constructed of glass, TFE-fluorocarbon, or other relatively inert material. It shall be of sufficient diameter to cause a negligible pressure drop at the photometer connection and other output ports. The output manifold serves the function of providing an interface between the calibration system and other devices and systems that utilize the output O_3 concentrations. It shall have one or more ports for connection of the external instruments or systems, and shall be such that all ports provide the same O_3 concentrations. The vent, which exhausts excess gas flow from the system and

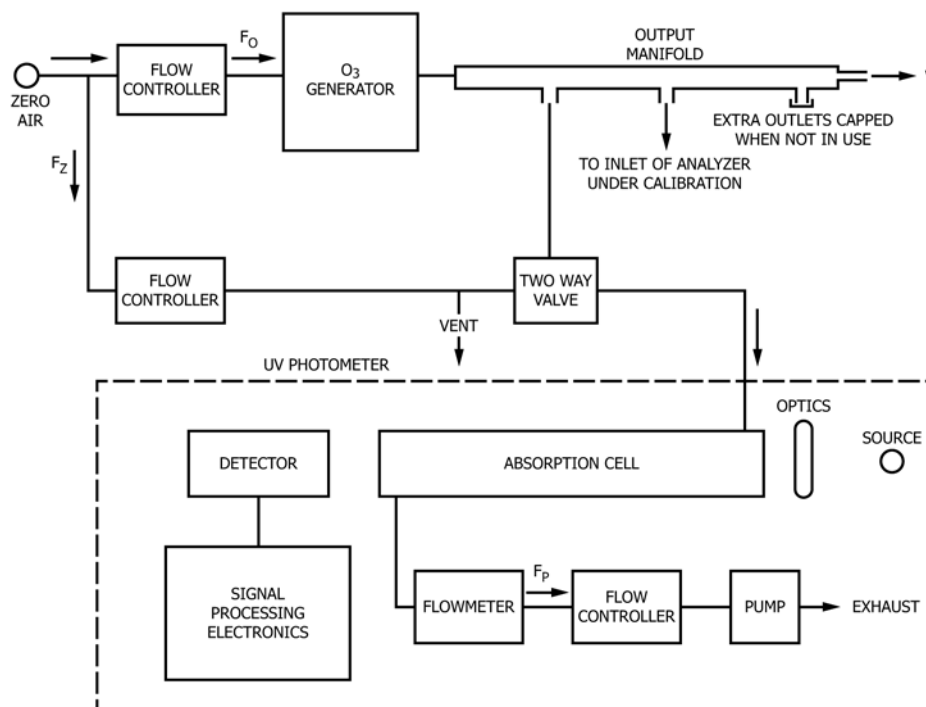

FIG. 1 Schematic Diagram of a Typical UV Photometric Calibration System

insures that the manifold outlet ports are maintained at atmospheric pressure for all flowrates, shall be large enough to avoid appreciable pressure drop, and shall be located downstream of the output ports to insure that no ambient air enters the manifold due to eddy currents, back diffusion, etc.

6.1.1.6 *Temperature Indicator*, accurate to $\pm 1^\circ\text{C}$. This indicator is needed to measure the temperature of the gas in the photometric cell in order to calculate a temperature correction. In most photometers, particularly those whose cell is enclosed inside a case or housing with other electrical or electronic components, the cell operates at a temperature somewhat above ambient room temperature. Therefore, it is important to measure the temperature of the gas inside the cell, and not room temperature. A small thermocouple or thermistor, connected to an external readout device, may be attached to the cell wall or inserted through the cell wall to measure internal temperature.

6.1.1.7 *Barometer or Pressure Indicator*, accurate to ± 250 Pa. The barometer or pressure indicator is used to measure the pressure of the gas in the cell in order to calculate a pressure correction. Most photometer cells operate at atmospheric pressure. If there are no restrictions between the cell and the output manifold, the cell pressure should be very nearly the same as the local barometric pressure. A certified local barometric pressure reading can then be used for the pressure correction. If the cell pressure is different than the local barometric pressure, some means of accurately measuring the cell pressure (manometer, pressure gage, or pressure transducer) is required. This device shall be calibrated against a suitable pressure standard, in accordance with Test Methods D3631.

6.1.2 *Output Indicating Device, such as Continuous Strip Chart Recorder or Digital Volt Meter*—If a recorder is used, it shall have the following specifications:

Accuracy	$\pm 0.25\%$ of span
Chart width	no less than 150 mm
Time for full-scale travel	1 s

6.1.2.1 If a digital voltmeter is used, it shall have an accuracy of $\pm 0.25\%$ of range.

6.1.2.2 Practice A output indicating device shall be considered as part of the transfer standard, and employed during qualification, certification, and use.

6.1.2.3 Practices C, D, and E require two output indicating devices.

6.1.3 *Variable Autotransformer*.

6.1.4 *AC Voltmeter*, accurate to $\pm 1\%$.

6.2 *Apparatus Common to Practices A and D:*

6.2.1 *Ozone Monitor:*

6.2.1.1 *Practice A*—An ozone monitor used as a transfer standard shall receive special treatment consistent with its authoritative status: that is, careful handling and storage, frequent maintenance, a QA program, operation by a competent and trained technician. In particular, it shall not be used for ambient monitoring between uses as a transfer standard, as dust and dirt will affect its accuracy.

6.3 *Apparatus Common to Practices C and D*—Fig. 2, a schematic of a typical GPT apparatus, shows the suggested configuration listed below. All connections shall be glass or TFE-fluorocarbon. See Ellis (5) for additional information regarding the assembly and use of the GPT calibration apparatus.

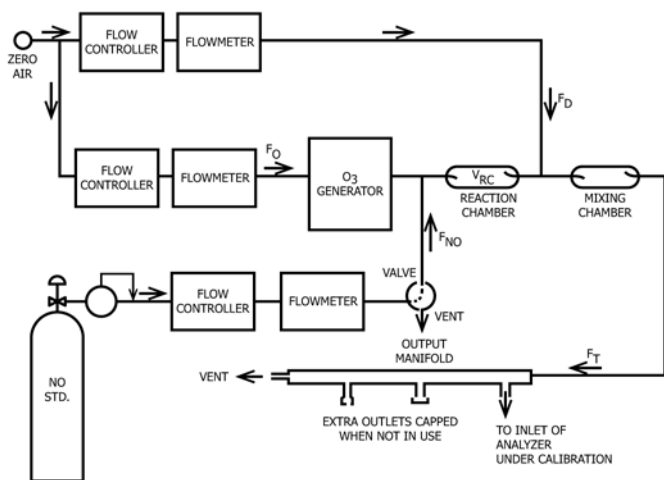

FIG. 2 Schematic Diagram of a Typical GPT System

6.3.1 Nitric Oxide Flow Controller—A device capable of maintaining constant NO flow within $\pm 2\%$. Component parts in contact with NO shall be of a non-reactive material.

6.3.2 Nitric Oxide Flowmeter—A flowmeter capable of measuring NO flows within $\pm 2\%$, and shall be calibrated according to Practice D3195. (Warning—Rotameters have been reported to operate unreliably when measuring low NO flows, and are not recommended.)

6.3.3 NO Cylinder Pressure Regulator—This regulator shall have non-reactive internal components, and shall include a purge port.

6.3.4 Reaction Chamber—A glass chamber for the quantitative reaction between O₃ and NO. It shall be of sufficient volume that the reaction time is less than two minutes.

6.3.5 Mixing Chamber—A glass chamber to provide for mixing of reaction products and dilution air.

6.4 Apparatus for Practice B Alone:

6.4.1 Sampling Train (see Fig. 3), consisting of:

6.4.1.1 Glass Midget Impingers—Two impingers connected in series.

6.4.1.2 Air Pump and Flow Controller—Any air pump and flow controller capable of maintaining a constant flow of 0.4 to 0.6 L/min through the impingers. A critical orifice, as described by Lodge et al. (6), is recommended. The orifice shall be protected from moisture and particulate matter with a membrane filter or trap containing Drierite, silica gel, and glass wool. The air pump shall be capable of maintaining a pressure differential of at least 60 to 70 kPa across the critical orifice.

6.4.2 Spectrophotometer—Capable of measuring absorbance at 352 nm with an absolute accuracy of $\pm 1\%$, and with a linear response over the range of 0 to 1.0 absorbance units. The accuracy shall be verified using optical glass filters with certified absorbance values at specified wavelengths. Matched 10-mm or 20-mm cells shall be used.

6.4.3 pH meter, with a resolution of ± 0.1 pH units.

6.5 Apparatus for Practice C Alone:

6.5.1 Chemiluminescence Nitric Oxide Monitor—The NO channel of a chemiluminescence NO/NO₂/NO_x monitor shall

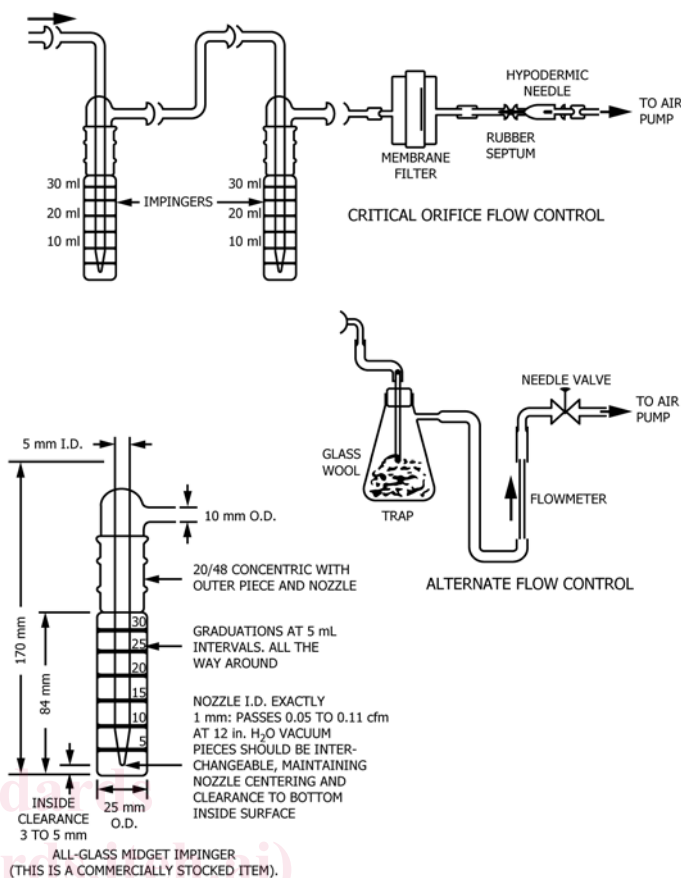

FIG. 3 Components of a KI Sampling Train

meet the requirements of Test Methods D3824 or the performance requirements for Reference Methods for NO₂ monitors in 40 CFR Part 50.

6.6 Apparatus for Practice D Alone: -d5011-17

6.6.1 Ozone Generator—The generator shall be of the UV lamp type, with means to adjust the O₃ concentration over a convenient range without changing the flowrate. It shall have an output manifold similar to that described in 6.1.1.5, and a zero air supply as described in 7.1.1.1.

7. Reagents and Materials

7.1 Reagents Common to Practices A Through E:

7.1.1 Zero Air, free of O₃ and any substance that might react with O₃ or undergo photolysis (for example, NO, NO₂, ethylene or other hydrocarbons, and particulate matter). The air shall be purified to remove such substances. Dirty air shall be precleaned to remove particulate matter, oil mist, liquid water, etc.

7.1.1.1 A system which has been used successfully is described as follows: the air is dried with a membrane type dryer, followed by a column of indicating silica gel. The air is irradiated with a UV lamp to generate O₃ to convert NO to NO₂, and passed through a column of activated charcoal (1.40 mm to 3.35 mm) to remove NO₂, O₃, hydrocarbons, and various other substances, and is followed by a column of molecular sieve (1.18 mm to 3.35 mm, type 4A), and a final particulate filter (2 micron) to remove particulate matter.

7.1.1.2 If a chemiluminescent O₃ monitor is being calibrated, the interference by high humidity shall be checked.

7.2 Reagents and Materials for Practice B Only:

7.2.1 *Purity of Reagents*—Reagent grade chemicals shall be used in all tests. All reagents shall conform to the specifications of the Committee on Analytical Reagents of the American Chemical Society where such specifications are available.⁶ Other grades may be used, provided it is first ascertained that the reagent is of sufficiently high purity to permit its use without lessening the accuracy of the determination.

7.2.2 *Purity of Water*—References to water shall mean reagent water as defined by Type 2 of Specification **D1193**.

7.2.3 *Absorbing Reagent*—Dissolve 6.2 g of boric acid (H₃BO₃) in 750 mL of water in an amber 1000 mL volumetric flask. The flask may be heated gently to speed dissolution of the boric acid, but the solution must be cooled to room temperature or below before proceeding. (While the boric acid solution is cooling, prepare the H₂O₂ solution (7.2.6).) When cooled, add 10 g of KI to the H₃BO₃ and dissolve. Add 1 mL of H₂O₂ (7.2.6) solution and mix. Within 5 minutes after adding the H₂O₂, dilute to volume with water, mix, and determine the absorbance of this BAKI solution at 352 nm against water as the reference. The pH of the BAKI solution shall be 5.1 ± 0.02.

7.2.3.1 Set the absorbing solution aside for two hours, and redetermine the absorbance at 352 nm against water as the reference. If the resulting absorbance from the second determination is at least 0.008 absorbance units/cm greater than the first determination, the solution is ready for use. If no increase or an increase of less than 0.008 absorbance units/cm is observed, the KI reagent probably contains an excessive amount of a reducing contaminant, and must be discarded. If an unacceptable absorbing reagent results from different lots of KI, test the possibility of contamination in the H₃BO₃ by using a different numbered lot of H₃BO₃.

7.2.4 *Boric Acid* (H₃BO₃).

7.2.5 *Hydrogen Peroxide* (H₂O₂)—3 % or 30 %.

7.2.6 *Hydrogen Peroxide Solution* (0.0021 %)—Using a graduated pipet, add 0.7 mL of 30 % or 7.0 mL of 3 % H₂O₂ (7.2.5) to 200 mL of water in a 500 mL volumetric flask, dilute to volume with water, and mix. Pipet 5 mL of the above solution into 50 mL of water in a 100 mL volumetric flask, dilute to volume with water, and mix. Both solutions must be prepared fresh every time a fresh batch of absorbing solution is prepared.

7.2.7 *Potassium Iodide* (KI).

7.2.8 *Potassium Iodate* (KIO₃), certified 0.1 N.

7.2.9 *Sulfuric Acid* (H₂SO₄)—95 to 98 %.

7.2.10 *Sulfuric Acid* (1 N)—Dilute 28 mL of concentrated H₂SO₄ (7.2.9) to volume in a 1 L volumetric flask by adding the acid to the water.

7.2.11 Standard Solutions:

7.2.11.1 Pipet 10 mL of 0.1 N KIO₃ solution (7.2.8) into a 100 mL volumetric flask containing 50 mL of water. Add 1 g KI (7.2.7) and 5 mL of 1 N H₂SO₄ (7.2.10), dilute to volume with water, and mix.

7.2.11.2 Immediately before use, pipet 10 mL of the I₂ solution (7.2.11.1) into a 100 mL volumetric flask, and dilute to volume with water. Then pipet 10 mL of this solution into a 200 mL volumetric flask, and dilute to volume with absorbing reagent (7.2.3).

7.2.11.3 In turn, pipet 5, 10, 15, 20, and 25 mL aliquots of the final solution (7.2.11.2) into 25 mL volumetric flasks. Dilute to volume with absorbing reagent (7.2.3), and mix. To prevent loss of I₂ by volatilization, the flasks shall remain stoppered until absorbance measurements are made. Absorbance measurements shall be made within 20 minutes after preparation of the I₂ standards (see Section **A2.4**).

7.3 Reagents and Materials for Practices C Only:

7.3.1 *Nitric Oxide Concentration Standard*—Compressed gas cylinder containing 50 to 100 ppm NO in N₂. This need not be NIST⁷ traceable, but a useful check of the transfer standard's accuracy is obtained if the NO standard is traceable to an NIST Standard Reference Material (SRM 1629). With a traceable NO standard, the transfer standard's indicated O₃ concentration shall agree with the UV standard within -5 % to +15 % (most GPT-NO systems have a positive bias). If it does not agree within this envelope, a problem with either the transfer standard or the primary standard is indicated, and standards shall be established using new sources.

7.4 Reagents and Materials for Practice D Only:

7.4.1 *Nitric Oxide Concentration Standard*—Compressed gas cylinder containing 50 to 100 ppm NO in N₂, traceable to an NIST Standard Reference Material (SRM 1629 or SRM 1684) or NO₂ Standard Reference Material (SRM 1629). The cylinder shall be recertified on a regular basis as determined by a quality control program.

8. Hazards

8.1 *Safety Hazards*—See Practice **D3249** for safety precautions on the use of monitors and electronic equipment.

8.1.1 Ozone is a toxic material. See Practice **E591** for biological effects, and for safety and health requirements.

8.1.2 The manifold vents and photometer and monitor exhausts must be vented to remove exhaust gases from the workplace. Measures must be taken to avoid a back pressure in the cell and manifold, and in the monitor or transfer standard being calibrated.

9. Establishing the Authority of Transfer Standards

9.1 The primary purpose of an O₃ transfer standard is to transfer the authority of a primary O₃ standard from one time and place to another. Since a transfer standard has no authority of its own, its authority must be first established by confirming a high probability or confidence that O₃ concentration standards obtained, under a variety of operating conditions, are

⁶ Reagent Chemicals, American Chemical Society Specifications, American Chemical Society, Washington, DC. For suggestions on the testing of reagents not listed by the American Chemical Society, see *Analar Standards for Laboratory Chemicals*, BDH Ltd., Poole, Dorset, U.K., and the *United States Pharmacopeia and National Formulary*, U.S. Pharmacopeial Convention, Inc. (USPC), Rockville, MD.

⁷ Available from National Institute of Standards and Technology (NIST), 100 Bureau Dr., Stop 1070, Gaithersburg, MD 20899-1070, <http://www.nist.gov>.

very nearly as accurate as primary O₃ standard. This confidence is first established by determining that the transfer standard has adequate reproducibility to qualify it as a transfer standard, then by certifying the transfer standard by relating it to a primary standard, and finally by periodically recertifying it by reverifying its accuracy and stability.

9.2 *Comparing Transfer Standards to Primary Ozone Standard*—Basic to the qualification and certification of an O₃ transfer standard is the need to compare the output (either a concentration determination or an O₃ concentration) of the transfer standard to the primary standard, so that relationships can be determined.

9.2.1 *Assay-Type Transfer Standards*—For transfer standards that provide an assay of an externally generated O₃ concentration (Practices A and B), the transfer standard is connected to the output manifold shown in Fig. 1 and Fig. 4. There shall be sufficient flow of ozonized air for both the primary and secondary standards. The output of the transfer standard is an indicated concentration, which is compared directly to the primary standard concentration obtained from the primary standard.

9.2.2 *Ozone-Generation Type Transfer Standards*—Transfer standards that generate O₃ concentrations themselves include O₃ generators (Practice E) and may include those assay procedures that have an integral source of O₃ (Practices C and D). Three procedures that may be used to compare the transfer standard to the primary standard are described in Annex A5. They are presented in order of preference.

9.3 *Qualification*—The first step in establishing the authority of a candidate transfer standard is to prove that it qualifies for use as a transfer standard. It must be demonstrated that the output of the transfer standard is reproducible and repeatable

under the changing conditions that might be encountered in field use. A transfer standard must be assumed unacceptable until it can be conclusively demonstrated to be acceptable.

9.3.1 The primary requirement of a transfer standard is repeatability under the stress of variable conditions that may change between certification in the laboratory and use in the field. A candidate transfer standard is qualified by proving that it is repeatable over an appropriate range for each variable likely to change between the time and place of certification, and the time and place of use. According to the specifications in Annex A1, the repeatability must be between ±4 % or ±4 ppb, whichever is greater, for each condition or variable that may change between the point of certification and the point of use.

9.3.2 Selecting the conditions that are likely to vary and may affect the repeatability is largely a matter of intelligent informed judgment. It is the user's responsibility to determine all of the conditions to be considered in the demonstration of repeatability, and to document the choices, and the reasons for them. Common conditions likely to affect a wide variety of transfer standards include ambient temperature, line voltage and frequency, barometric pressure, elapsed time, physical shock, and relocation. Conditions not likely to affect the transfer standard can be usually eliminated from consideration. The user, however, must be constantly alert for the unusual situation where an unexpected condition is present.

9.3.3 It should be noted that a transfer standard does not necessarily need to be constant with respect to the variables, but only repeatable or predictable. Demonstration of repeatability for a candidate transfer standard normally requires testing for each condition that could or may affect it. Typical tests for common conditions are discussed in Section 10. For

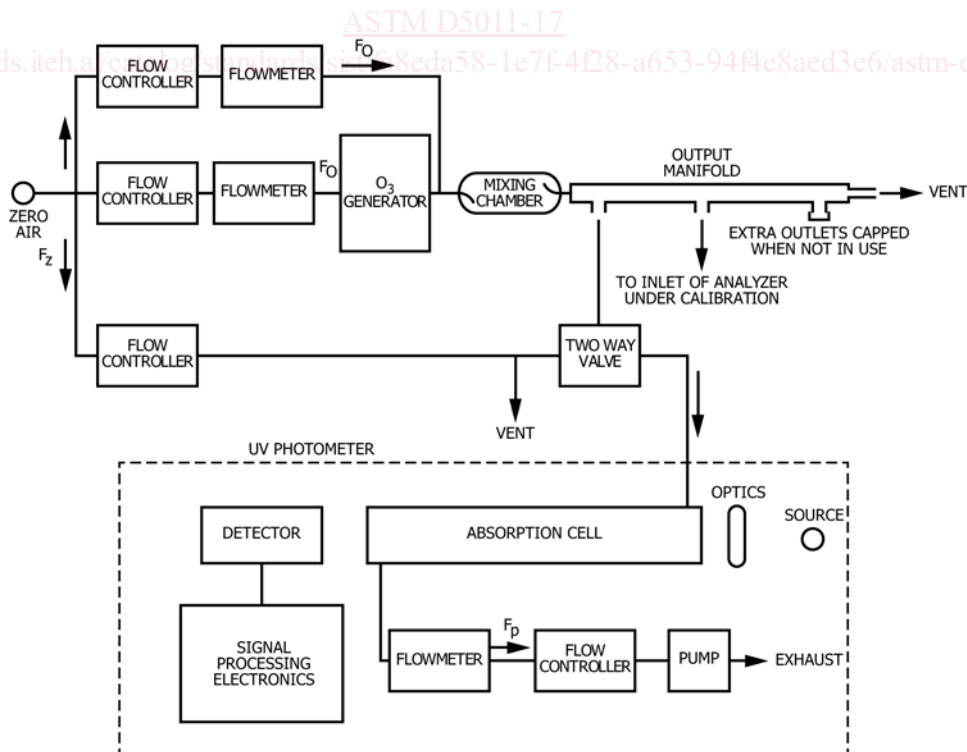

FIG. 4 Schematic Diagram of a Typical UV Photometric Calibration System (Option 1)

qualification of procedural candidates such as Practices B, C, or D, testing may be minimal, provided the user is adequately trained, uses good laboratory technique, and uses a specific apparatus and set of supplies. For commercially available transfer standards, some or all of the testing may have been carried out by the manufacturer. In some cases it may be possible to judiciously substitute design rationale for actual testing. For example, a device whose power supply is designed to be highly regulated may not require specific line voltage tests. However, such situations should be viewed with considerable skepticism because of the possibility of failure of a component.

9.3.4 This brings up the further question of whether candidate transfer standards must be tested individually or whether they can be qualified by type, model, or user. In the case of procedural candidates such as Practices B, C, or D, each user must qualify them in the laboratory/use situation in which it will be used, since the procedures have a number of potential variables. Commercial transfer standards are designed and manufactured to be identical. The manufacturer could carry out the necessary qualification tests on representative samples under this concept. It shall be appropriate to require that the manufacturer guarantee that each unit meet appropriate performance specifications, and provide documentation accordingly. Again, the user should assume a skeptical attitude, and at least carry out some minimal tests to verify that each unit is acceptable.

10. Qualification Tests

10.1 Some of the more common conditions likely to be encountered or to change while using transfer standards, and that may affect the repeatability of the device are discussed below. The exact conditions or variables that must be considered depend on the specific nature of the transfer standard or procedure. The user (or manufacturer) shall determine the conditions for each case on an intelligent judgment basis derived from a complete understanding of the operation of the device or procedure and supported by appropriate rationale.

10.2 Once the conditions to be considered have been determined, the objective of the qualification tests is either 10.2.1 or 10.2.2:

10.2.1 To determine that the candidate transfer standard's output is not affected by more than $\pm 4\%$ or ± 4 ppb (whichever is greater) by the condition over the range likely to be encountered during use of the transfer standard.

10.2.2 To demonstrate the candidate transfer standard's output is repeatable within $\pm 4\%$ or ± 4 ppb (whichever is greater) as the variable is changed over the range likely to be encountered during use, and to quantify the relationship between the output and the variable.

10.3 *Temperature*—Changes in ambient temperature are likely to occur from place to place and from one time to another. Temperature changes are likely to affect almost all types of transfer standards unless appropriate means are used to avoid adverse effects. Temperature affects transfer standards in many ways: changes in action of components, changes in chemical reactions or rates of reaction, volume changes of gases, electronic drift, variable warm-up time, etc. The most

important effects are changes in the output of generation devices, changes in the sensitivity of O₃ assay systems, and changes in the volume of air flows which must be measured accurately.

10.3.1 Temperature effects may be minimized in several ways. The easiest way is to restrict the use of the transfer standard to a temperature range over which the effects are within the specification. This restriction may be the only practical approach for some candidate transfer standards, but it may preclude use of such a transfer standard in too many situations. Transfer standard devices may be insensitive to temperature changes by design, such as thermostatic regulation of sensitive components or of the entire device, or by temperature compensation.

10.3.2 Temperature effects on flow measurements may be minimized by the use of mass flowmeters, which do not measure volume, or by the regulation of gas temperature. Alternately, ideal-gas-law corrections may be made to adjust measured values. See Practice D3195 for appropriate formulas for corrections.

10.3.3 Testing a candidate transfer standard for sensitivity to temperature is facilitated by use of a controlled temperature chamber. However, temperature tests may be carried out in many ordinary laboratories where the temperature may be manually controlled by adjusting thermostats, blocking air vents or outlets, opening doors or windows, or using supplemental heaters or air conditioners. A reasonable temperature range is 20° to 30°C. Broader temperature ranges could be used if necessary for special situations.

10.3.4 The candidate transfer standard is tested by comparing its output to a stable concentration reference, which shall be an UV photometer system. See Practice D5110. The reference may also be another transfer standard known to be repeatable and, in particular, insensitive to temperature changes. However, it would be better to locate the reference outside of the variable temperature area. The candidate transfer standard shall be tested at several different points over the temperature range, including the extremes, and at several different concentrations. Sufficient time shall be allowed for all components of the calibration system to equilibrate each time the temperature is changed. The test results shall be plotted as shown in Fig. 5.

10.3.5 If the candidate transfer standard has a significant temperature dependence, additional test points at various concentrations and temperature shall be taken to define the relationship between output and temperature accurately. Furthermore, if the candidate transfer standard has a dependence on more than one variable, tests shall be carried out over the range of both variables simultaneously to determine any interdependence between the two variables. Once the test data are acquired, they shall be analyzed to determine if some general formula or curve can be derived (either analytically or empirically) to predict the correct O₃ concentration at any temperature in the range (see Fig. 6). The correction formula or curve shall be accurate within $\pm 4\%$ or ± 4 ppb, whichever is greater. If two or more variables are involved, a family of curves may be required; unless the relationship is simple, this situation may prove impractical in actual use.

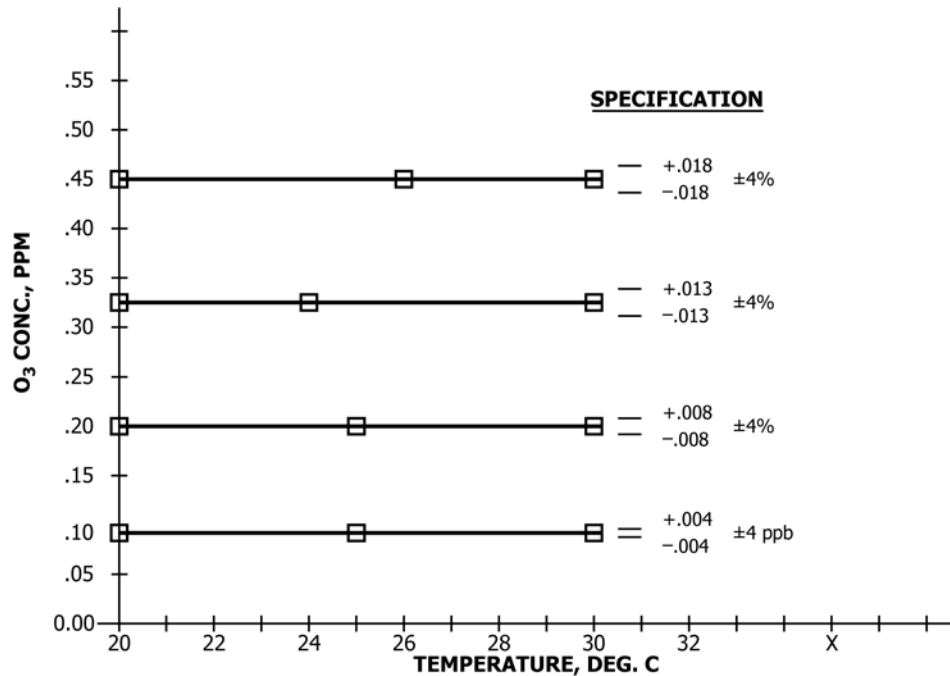

FIG. 5 Example of Temperature Qualification Test Results Showing no Dependence on Temperature

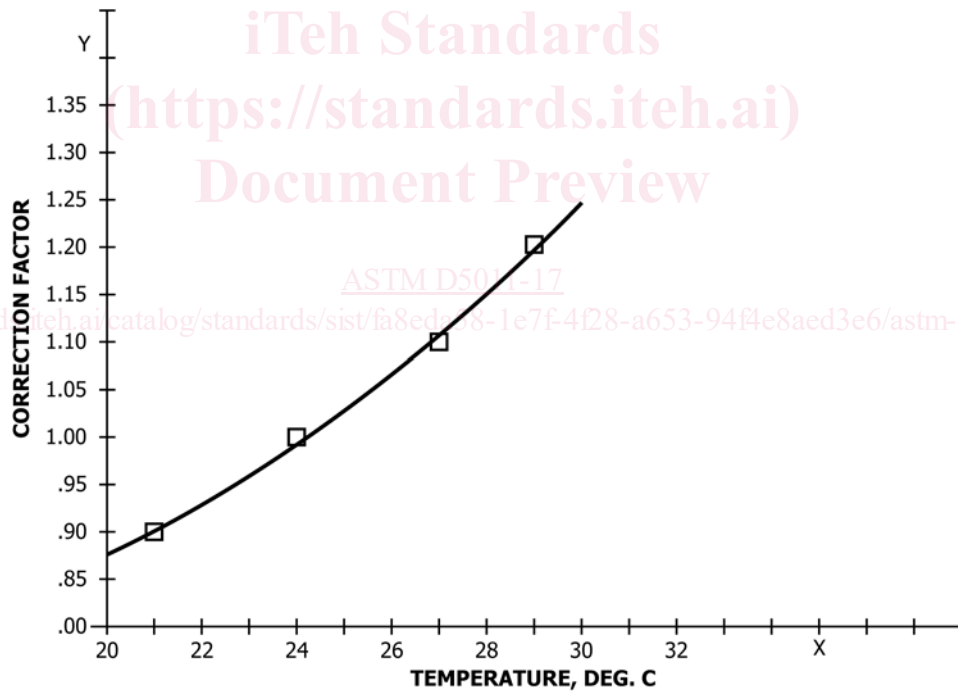

FIG. 6 Example of a Temperature Dependence Quantitatively Defined as a Correction Factor

10.4 *Line Voltage*—Line voltage may vary from place to place, and from one time to another. Good electrical or electronic design of the transfer standard shall avoid sensitivity to line voltage variations, but poorly designed equipment may easily be affected. In addition, line voltage sensitivity may appear only as a long time thermal drift, which is a subtle effect.

10.4.1 Aside from adequate design, line voltage effects may be minimized by the addition of a line voltage regulator. However, such devices may distort the line voltage waveform, thereby adversely affecting some types of transfer standards. If such regulators are used, it is important the same regulator is used both during certification and use of the transfer standards. Restriction of the transfer standards to a line voltage range in

which effects are insignificant is another alternative, but requires monitoring the voltage during use, and may preclude use at some sites.

10.4.2 Testing for line voltage sensitivity may be conducted along the same lines as described for temperature testing. The line voltage may be varied by means of a variable autotransformer and measured by an accurate ac voltmeter. Do not use electronic “dimmer” controls which operate on a delayed-conduction principle, as such devices cause drastic waveform distortions.

10.4.3 A line voltage range of 105 to 125 V should adequately cover the majority of line voltages available.

10.4.4 If the transfer standard is used when power is from a small power generator, the frequency variation shall be checked.

10.5 *Barometric Pressure/Altitude*—Since O₃ concentrations are gaseous, all transfer standards will have some basic or inherent sensitivity to changes in barometric pressure. It is difficult to minimize pressure effects by design. Air pressure can be regulated mechanically against an absolute reference, but most such schemes are not practical when working with O₃ concentrations because of restrictions to inert material such as glass or TFE-fluorocarbon. With Practices B, C, and D, the effect is limited primarily to the measurements of flowrates, which were discussed in 10.3, and are applicable to barometric pressure changes as well. At a constant altitude, normal day-to-day variations in barometric pressure is only a few percent. If the use of the transfer standards can be restricted to altitudes within a hundred metres of the certification altitude, it may be acceptable to neglect the barometric effect. However, if the use of the transfer standard is necessary at altitudes different than the certification altitude, then pressure effects may not be ignored.

10.5.1 Although not preventable, pressure effects are likely to be repeatable. As a result, barometric pressure may be the variable most likely to be handled by a defined relationship. The technique is similar to that used to determine a temperature relationship; a unique quantitative relationship will result. (**Warning**—In any work with O₃ concentrations at altitudes significantly above sea level, the concentration units must be clearly understood. The volume ratio concentration units (ppm, ppb, etc.) are independent of pressure, while density units such as µg/m³ are related to pressure. The µg/m³ unit defined and used by the U.S. EPA⁸ is “corrected” to 101.3 kPa and 25°C, and is therefore related to ppm by a constant.)

10.5.2 Testing barometric pressure effects may be difficult. The use of a variable pressure chamber is the best approach, but few laboratories have access to one. It is conceivable that various pressures may be obtained in a manifold setup, but construction of such an apparatus is difficult, and of questionable validity. The use of a mobile laboratory which may be driven to several altitudes to conduct tests may offer the best solution. Some types of transfer standards may not require pressure tests because their pressure variations are well known.

For Practices B, C, and D, the flow measurement problem constitutes the only pressure effect. Assay-types such as Practice A are directly related to gas density, and the ideal-gas law correction may be used. (See Practice D3195 for correction equations.) Pressure tests are not needed for these types. For commercially-available devices, the manufacturer is expected to perform the required qualification tests and to provide documentation.

10.6 *Elapsed Time*—As the elapsed time between certification and use increases, the confidence in the repeatability decreases. As a result, periodic recertification is required. Some types of O₃ generation devices have a definite loss of output (decay) with time. This decay is usually associated with use-time or on-time rather than with total elapsed time. Since the decay rate tends to be quantifiable, it may be accommodated with the defined relationship mechanism discussed in connection with temperature effects: the transfer standard is equipped with an hours meter, and a series of tests over a sufficient time period may then be used to determine the decay rate. During use, a correction to the output is applied based on the number of hours of on-time since the last certification.

10.6.1 Alternately, the transfer standard may be recertified often enough so the error due to decay never exceeds the specifications in Annex A1.

10.7 *Variability*—The preciseness of the relationship between a transfer standard and a primary O₃ standard is dependent on the variability of the transfer standard. Variability reduces confidence in the accuracy of a certified transfer standard. A high degree of variability may be the cause for disqualifying a device or procedure for use as a transfer standard, or for selecting one with lower variability. Although the certification procedure in Section 11 includes a test for variability, more extensive tests for variability may be necessary to qualify a transfer standard because the certification test is for variability in the slope of the certification relationship and not for individual point variability. Furthermore, variability may be due to changes in conditions not encountered during certification.

10.7.1 Different types of transfer standards may have excessive variability for a variety of reasons. Qualification variability testing is most needed to test for the effect of a variety of non-specific or non-quantitative variables that cannot be tested individually. For example, qualification variability tests for Practices B, C, and D may include the use of various operators, various sources of chemicals and water, minor variations or substitutions of apparatus and components, etc. These tests may be conveniently combined with tests for relocation and operator adjustments described below. Whenever increased variability may be assigned to a specific cause, corrective actions or restrictions may be applied to reduce the variability.

10.7.2 Qualification testing for individual-point variability, unlike the certification variability test, shall be carried out on a single-point basis. A series of at least 6 single-point comparisons shall be made between the candidate transfer standard and the primary O₃ standard at each of at least two fixed concentrations—one low (less than 0.1 ppm) and one high (over 80 % of the upper range limit (URL)). These comparisons shall be made over a variety of conditions and situations

⁸ Available from United States Environmental Protection Agency (EPA), William Jefferson Clinton Bldg., 1200 Pennsylvania Ave., NW, Washington, DC 20460, <http://www.epa.gov>.