



Standard Specification for Test Methods and Specifications for Bicycle Manually Operated Front Wheel Retention Systems for Bicycles¹

This standard is issued under the fixed designation F2680; the number immediately following the designation indicates the year of original adoption or, in the case of revision, the year of last revision. A number in parentheses indicates the year of last reapproval. A superscript epsilon (ϵ) indicates an editorial change since the last revision or reapproval.

1. Scope

1.1 ~~This specification covers~~ These test methods and specifications cover the standard for front wheel retention systems for all bicycles equipped with manually operated retention systems such as a quick release.

1.2 This specification is only for bicycles equipped with manually operated retention systems, and does not apply to tool-operated wheel ~~fastening~~ retention systems.

1.3 The intent of this specification is to define the performance of primary and secondary wheel retention systems, with the focus on preventing unintended wheel ~~separation~~ separation and prevention of unintended contact of the retention system with the disc brake rotor or wheel.

1.4 The values stated in SI units are to be regarded as standard. No other units of measurement are included in this standard.

1.5 *This standard does not purport to address all of the safety concerns, if any, associated with its use. It is the responsibility of the user of this standard to establish appropriate ~~safety~~ safety, health, and ~~health~~ environmental practices and determine the applicability of regulatory limitations prior to use.*

1.6 *This international standard was developed in accordance with internationally recognized principles on standardization established in the Decision on Principles for the Development of International Standards, Guides and Recommendations issued by the World Trade Organization Technical Barriers to Trade (TBT) Committee.*

2. Terminology

2.1 *Definitions of Terms Specific to This Standard:*

2.1.1 *adult bicycle, n*—bicycle designed for, and marketed to, adult riders.

2.1.2 *bicycle fork (fork), n*—~~mechanism~~ structure between the head tube and front hub axle, including some or all of the following components; the steerer tube, crown, fork blades, triple clamps, shock absorbers, lower tubes, upper tubes and dropouts (fork ends).

2.1.3 *direction of removal of the wheel from the fork, n*—direction, when both primary and secondary wheel retention systems are disengaged, that provides the least resistance to wheel and fork separation or wheel removal.

2.1.4 *disc brake, n*—a brake that uses a caliper to squeeze a pair of pads against a disc brake rotor in order to create friction that slows and stops the rotation of the wheel assembly.

2.1.5 *disc brake rotor, n*—the component of a disc brake against which the brake pads are pressed in order to stop. The rotor is attached to the wheel hub.

2.1.6 *dropout (fork end), n*—fork component used to support, or mount, the front wheel at the axle.

2.1.7 *manually operated, adj*—without the use of tools.

2.1.8 *primary retention, n*—system that keeps the bicycle wheel connected to the bicycle fork for riding.

2.1.9 *primary retention system in the unlocked position, n*—position where, (1) if a quick release cam is used, the cam is opened as far as possible or (2) if a turning style system such as a wing nut or another non-cam style system is used, the manual lever is loosened 360°.

¹ ~~This specification is~~ These test methods and specifications are under the jurisdiction of ASTM Committee F08 on Sports Equipment, Playing Surfaces, and Facilities and are the direct responsibility of Subcommittee F08.10 on Bicycles.

Current edition approved April 1, 2014; Sept. 1, 2017. Published May 2014; October 2017. Originally approved in 2009. Last previous edition approved in 2009/2014 as F2680–09; F2680–09 (2014). DOI: 10.1520/F2680-09R14; 10.1520/F2680-17.

2.1.10 *quick release mechanism; assembly, n*—lever-actuated cam mechanism that connects and retains the bicycle front wheel to the bicycle fork.

2.1.10.1 *Discussion*—

The assembly generally consists of a lever (actuating the cam mechanism), adjusting nut and springs (two, optional).

2.1.11 *secondary retention, n*—system that retains the bicycle wheel in the dropouts when the primary retention system is in the open (unlocked) position.

2.1.12 *wheel hub, n*—assembly consisting of an axle connected by bearings to a hub shell, to which the spokes attach, and permitting the shell to revolve around the axle.

3. Performance Requirements

3.1 Bicycles equipped with a manually operated primary retention system shall be equipped with a secondary retention system.

3.2 The primary retention system shall prevent relative motion between the front wheel axle and the front fork dropouts when tested as shown in Fig. 1 by the methods described in 4.1.1 and as shown in Fig. 1.

3.3 The secondary retention system shall prevent front wheel removal or partial separation when tested by the methods described in 4.1.2. An example of one type of Examples of front wheel partial separation is are shown in Fig. 2.

3.4 Manually operated wheel retention systems shall not be used on bicycles with 20-in. (51-cm) diameter wheels or smaller (excluding adult bicycles).

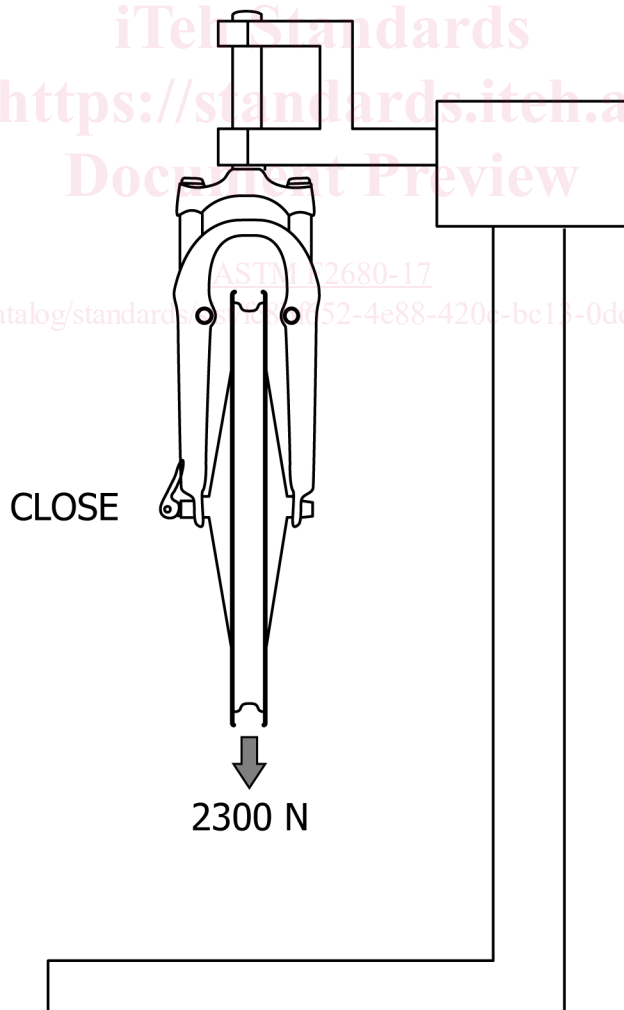

FIG. 1 Typical Primary Retention Test Apparatus

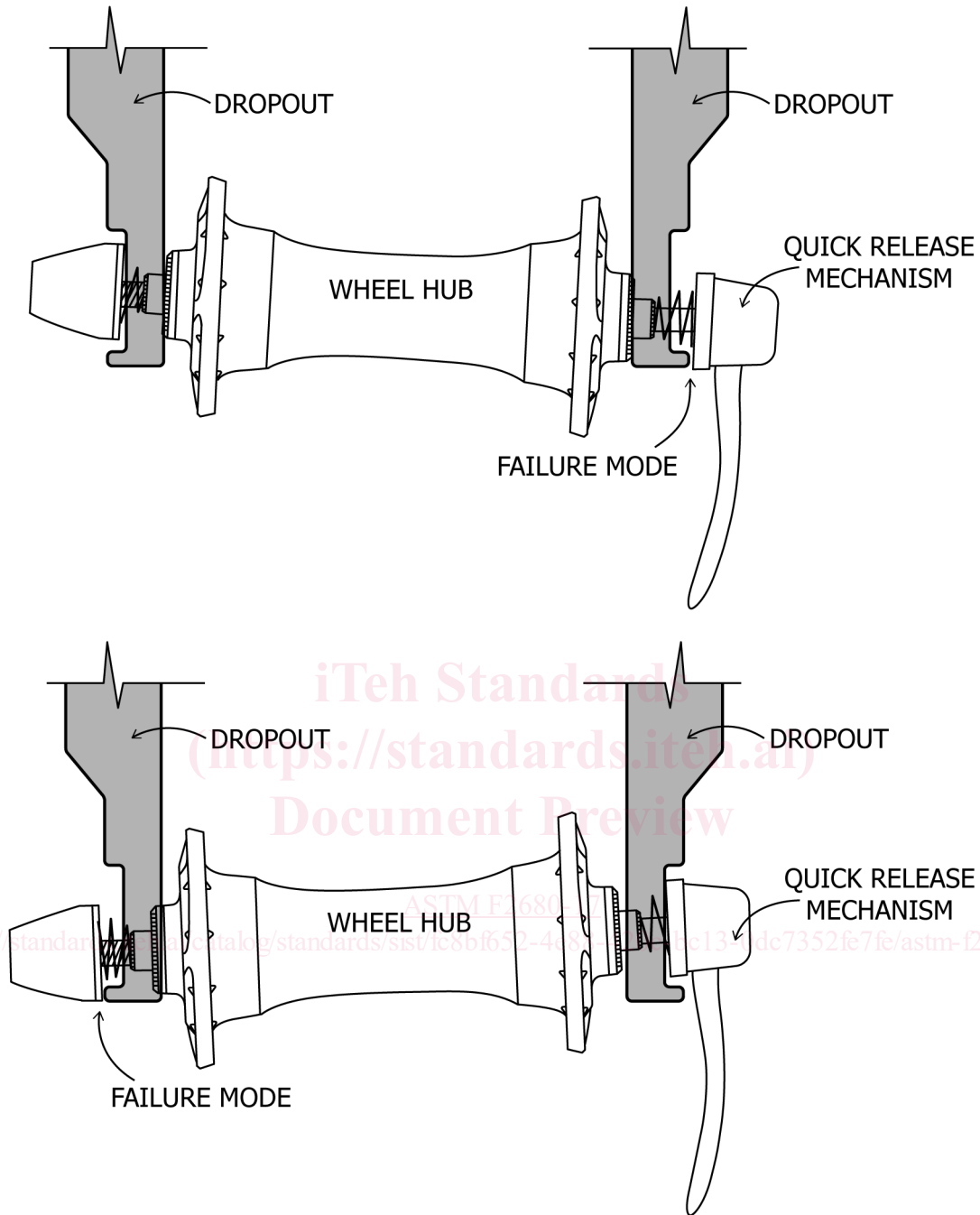

FIG. 2 Failure Mode Examples

3.5 When the quick release assembly is installed into the test fixture (Fig. 3), the quick release lever shall not contact the fixture surface at any time during the test described in 4.2, in either an open or closed position (Fig. 4 and Fig. 5).

3.6 The quick release lever shall not interfere with the rotation of the wheel, including any attachments (for example, rotor), in either the open or closed position when the quick release is used as a system assembly (complete bicycle) and positioned according to the manufacturer's instructions.

4. Test Methods

4.1 *Test Setup*—Assemble and adjust the primary and secondary retention systems according to the manufacturer's instructions. Remove the braking system entirely or set to the state for wheel removal. ~~With no~~ Remove the tire ~~on~~ from the wheel, and mount the fork ~~non-rotatably mounted~~ only by the steerer tube: tube so that the fork cannot rotate (Fig. 1). Assemble and adjust the primary and secondary retention systems according to the manufacturer's instructions.

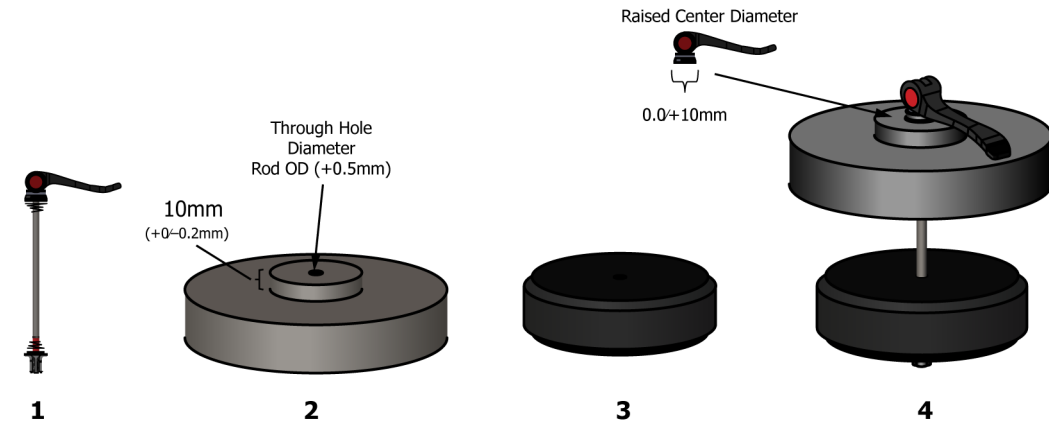

- Key:
 1 – Quick release assembly (Thru-Axle Assembly note shown)
 2 – Test fixture example (10 mm raised center)
 3 – 2.5 kg (5.51 lb) mass
 4 – Test fixture with quick release assembly and mass

NOTE 1—Ensure that the 10 mm raised section of the fixture does not interfere with the quick release lever arm when the lever is in the fully open or closed position. The diameter of the 10 mm raised section should be such that it can accommodate the test without contacting the lever arm.

FIG. 3 Test Fixture

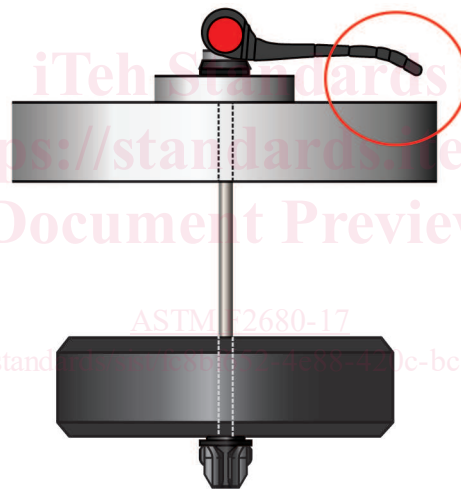

FIG. 4 Passing Result

4.1.1 *Primary Retention Test*—Lock the primary retention system for the riding condition and apply a force of 2300 N that is distributed symmetrically on the axle for a period of 1 min in the direction of removal of the wheel from the fork.

4.1.2 *Secondary Retention Test*—As shown in Fig. 36, with the primary retention system in the unlocked position, apply a Force “A” of 200 N distributed symmetrically on the axle in the direction of the removal of the wheel from the fork. While applying Force “A”, apply an additional separate 100 N Force “B” on the wheel rim as follows:

(1) *Location*—At the intersection of the extension of the Force “A” vector and a rim of maximum size compatible with the fork.

(2) *Direction*—Applied on the wheel rim in a direction parallel to the hub axle and on the line of the direction of removal of the front wheel.

(3) *Duration*—Apply force for 1 min, then reduce Force “B” to zero as quickly as possible while maintaining Force “A”. Then reduce Force “A” to zero.

4.1.2.1 Repeat 4.1.2 with Force “B” applied on the opposite side of the wheel (as shown in Fig. 47).

4.1.2.2 If the wheel mounting system allows the wheel to be mounted in a reversible manner, re-mount the wheel reversed in the bicycle fork, an example of which is shown in Fig. 5.

4.1.2.3 Repeat the test described in 4.1.2 with the assembly shown in Fig. 5.

4.1.2.2 Repeat the test described in 4.1.2.1 if the quick release lever can be manually installed on either side of the fork, the test shall be performed with the assembly shown in lever on each side. See Fig. 6 and Fig. 8.