



Designation: C496/C496M – 17

Standard Test Method for Splitting Tensile Strength of Cylindrical Concrete Specimens¹

This standard is issued under the fixed designation C496/C496M; the number immediately following the designation indicates the year of original adoption or, in the case of revision, the year of last revision. A number in parentheses indicates the year of last reapproval. A superscript epsilon (ϵ) indicates an editorial change since the last revision or reapproval.

1. Scope*

1.1 This test method covers the determination of the splitting tensile strength of cylindrical concrete specimens, such as molded cylinders and drilled cores.

1.2 The values stated in either SI units or inch-pound units are to be regarded separately as standard. The values stated in each system may not be exact equivalents; therefore, each system shall be used independently of the other. Combining values from the two systems may result in non-conformance with the standard.

1.3 *This standard does not purport to address all of the safety concerns, if any, associated with its use. It is the responsibility of the user of this standard to establish appropriate safety, health, and environmental practices and determine the applicability of regulatory limitations prior to use.*

1.4 The text of this standard references notes that provide explanatory material. These notes shall not be considered as requirements of the standard.

1.5 *This international standard was developed in accordance with internationally recognized principles on standardization established in the Decision on Principles for the Development of International Standards, Guides and Recommendations issued by the World Trade Organization Technical Barriers to Trade (TBT) Committee.*

2. Referenced Documents

2.1 *ASTM Standards:*²

[C31/C31M Practice for Making and Curing Concrete Test Specimens in the Field](#)

[C39/C39M Test Method for Compressive Strength of Cylindrical Concrete Specimens](#)

[C42/C42M Test Method for Obtaining and Testing Drilled Cores and Sawed Beams of Concrete](#)

[C125 Terminology Relating to Concrete and Concrete Aggregates](#)

[C192/C192M Practice for Making and Curing Concrete Test Specimens in the Laboratory](#)

[C670 Practice for Preparing Precision and Bias Statements for Test Methods for Construction Materials](#)

3. Terminology

3.1 *Definitions*—For definitions of terms used in this test method, refer to Terminology [C125](#).

4. Summary of Test Method

4.1 This test method consists of applying a diametral compressive force along the length of a cylindrical concrete specimen at a rate that is within a prescribed range until failure occurs. This loading induces tensile stresses on the plane containing the applied load and relatively high compressive stresses in the area immediately around the applied load. Tensile failure occurs rather than compressive failure because the areas of load application are in a state of triaxial compression, thereby allowing them to withstand much higher compressive stresses than would be indicated by a uniaxial compressive strength test result.

4.2 Thin, plywood bearing strips are used to distribute the load applied along the length of the cylinder.

4.3 The maximum load sustained by the specimen is divided by appropriate geometrical factors to obtain the splitting tensile strength.

5. Significance and Use

5.1 Splitting tensile strength is generally greater than direct tensile strength and lower than flexural strength (modulus of rupture).

5.2 Splitting tensile strength is used in the design of structural lightweight concrete members to evaluate the shear resistance provided by concrete and to determine the development length of reinforcement.

¹ This test method is under the jurisdiction of ASTM Committee C09 on Concrete and Concrete Aggregates and is the direct responsibility of Subcommittee C09.61 on Testing for Strength.

Current edition approved Oct. 1, 2017. Published October 2017. Originally approved in 1962. Last previous edition approved in 2011 as C496/C496M-11. DOI: 10.1520/C0496_C0496M-17.

² For referenced ASTM standards, visit the ASTM website, www.astm.org, or contact ASTM Customer Service at service@astm.org. For *Annual Book of ASTM Standards* volume information, refer to the standard's Document Summary page on the ASTM website.

*A Summary of Changes section appears at the end of this standard

6. Apparatus

6.1 *Testing Machine*—The testing machine shall conform to the requirements of Test Method C39/C39M and be of a type with sufficient capacity that will provide the rate of loading prescribed in 8.5.

6.2 *Supplementary Bearing Bar or Plate*—If the diameter or the largest dimension of the upper bearing face or the lower bearing block is less than the length of the cylinder to be tested, a supplementary bearing bar or plate of machined steel shall be used. The surfaces of the bar or plate shall be machined to within ± 0.025 mm [± 0.001 in.] of planeness, as measured on any line of contact of the bearing area. It shall have a width of at least 50 mm [2 in.], and a thickness not less than the distance from the edge of the spherical or rectangular bearing block to the end of the cylinder. The bar or plate shall be used in such manner that the load will be applied over the entire length of the specimen.

6.3 *Bearing Strips*—Two bearing strips of nominal 3.0 mm [$\frac{1}{8}$ in.] thick plywood, free of imperfections, approximately 25 mm [1 in.] wide, and of a length equal to, or slightly longer than, that of the specimen shall be provided for each specimen. The bearing strips shall be placed between the specimen and both the upper and lower bearing blocks of the testing machine or between the specimen and supplemental bars or plates, when used (see 6.2). Bearing strips shall not be reused.

7. Test Specimens

7.1 The test specimens shall conform to the size, molding, and curing requirements set forth in either Practice C31/C31M (field specimens) or Practice C192/C192M (laboratory specimens). Drilled cores shall conform to the size and moisture-conditioning requirements set forth in Test Method C42/C42M. Moist-cured specimens, during the period between their re-

moval from the curing environment and testing, shall be kept moist by a wet burlap or blanket covering, and shall be tested in a moist condition as soon as practicable.

7.2 The following curing procedure shall be used for evaluations of light-weight concrete: specimens tested at 28 days shall be in an air-dry condition after 7 days moist curing followed by 21 days drying at $23.0 \pm 2.0^\circ\text{C}$ [$73.5 \pm 3.5^\circ\text{F}$] and $50 \pm 5\%$ relative humidity.

8. Procedure

8.1 *Marking*—Draw diametral lines on each end of the specimen using a suitable device that will ensure that they are in the same axial plane (see Fig. 1, Fig. 2 and Note 1), or as an alternative, use the aligning jig shown in Fig. 3 (Note 2).

NOTE 1—Figs. 1 and 2 show a suitable device for drawing diametral lines on each end of a 150 mm × 300 mm [6 in. × 12 in.] cylinder in the same axial plane. The device consists of three parts as follows:

- (1) A length of 100-mm [4-in.] steel channel, the flanges of which have been machined flat,
- (2) A section, part a, that is grooved to fit smoothly over the flanges of the channel and that includes cap screws for positioning the vertical member of the assembly, and
- (3) A vertical bar, part b, for guiding a pencil or marker,

The assembly (part a and part b) is not fastened to the channel and is positioned at either end of the cylinder without disturbing the position of the specimen when marking the diametral lines.

NOTE 2—Fig. 4 is a detailed drawing of the aligning jig shown in Fig. 3 for achieving the same purpose as marking the diametral lines. The device consists of:

- (1) A base for holding the lower bearing strip and cylinder,
- (2) A supplementary bearing bar conforming to the requirements in Section 6 as to critical dimensions and planeness, and
- (3) Two uprights to serve for positioning the test cylinder, bearing strips, and supplementary bearing bar.

8.2 *Measurements*—Determine the diameter of the test specimen to the nearest 0.25 mm [0.01 in.] by averaging three

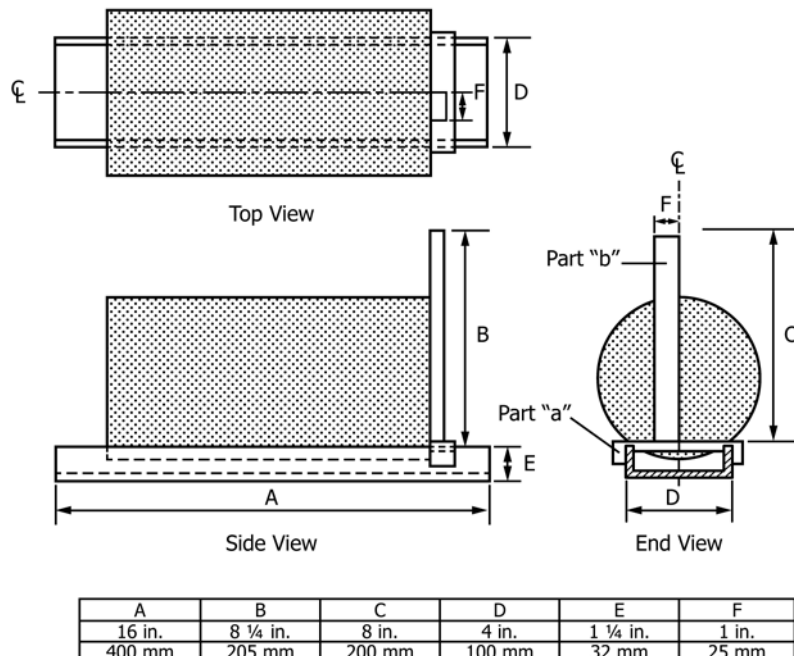

FIG. 1 General Views of a Suitable Apparatus for Marking End Diameters Used for Alignment of Specimen in Testing Machine