

---

# International Standard



# 4108

---

INTERNATIONAL ORGANIZATION FOR STANDARDIZATION • МЕЖДУНАРОДНАЯ ОРГАНИЗАЦИЯ ПО СТАНДАРТИЗАЦИИ • ORGANISATION INTERNATIONALE DE NORMALISATION

---

## Concrete — Determination of tensile splitting strength of test specimens

*Béton — Détermination de la résistance à la traction par fendage des éprouvettes*

First edition — 1980-02-15

**ITeH STANDARD PREVIEW**  
**(standards.iteh.ai)**

[ISO 4108:1980](https://standards.iteh.ai/catalog/standards/sist/7426c3e3-e45d-4853-b31b-11c0719e40d5/iso-4108-1980)

<https://standards.iteh.ai/catalog/standards/sist/7426c3e3-e45d-4853-b31b-11c0719e40d5/iso-4108-1980>



---

UDC 691.32 : 620.17

Ref. No. ISO 4108-1980 (E)

Descriptors : concrete, hardened concrete, compression tests, tensile strength.

## Foreword

ISO (the International Organization for Standardization) is a worldwide federation of national standards institutes (ISO member bodies). The work of developing International Standards is carried out through ISO technical committees. Every member body interested in a subject for which a technical committee has been set up has the right to be represented on that committee. International organizations, governmental and non-governmental, in liaison with ISO, also take part in the work.

Draft International Standards adopted by the technical committees are circulated to the member bodies for approval before their acceptance as International Standards by the ISO Council.

International Standard ISO 4108 was developed by Technical Committee ISO/TC 71, *Concrete, reinforced concrete and pre-stressed concrete*, and was circulated to the member bodies in May 1977.

It has been approved by the member bodies of the following countries:

Australia	Greece	Portugal
Austria	Hungary	Romania
Brazil	India	South Africa, Rep. of
Bulgaria	Israel	Spain
Canada	Italy	Turkey
Czechoslovakia	Mexico	United Kingdom
Denmark	Netherlands	USSR
Egypt, Arab Rep. of	New Zealand	Yugoslavia
France	Norway	
Germany, F. R.	Poland	

The member body of the following country expressed disapproval of the document on technical grounds :

Belgium

# Concrete — Determination of tensile splitting strength of test specimens

## 1 Scope and field of application

This International Standard specifies a method for the determination of the tensile splitting strength of test specimens of hardened concrete.

## 2 References

ISO 1920, *Concrete tests — Dimensions, tolerances and applicability of test specimens*.

ISO 2736, *Concrete — Sampling, making and curing of test specimens*.<sup>1)</sup>

ISO 4012, *Concrete — Determination of compressive strength of test specimens*.

## 3 Test specimens

### 3.1 Requirements

The test specimens used for the tensile splitting test shall meet the requirements given in ISO 1920 and ISO 2736. The

specimens should preferably be cylinders with a height to diameter ratio of 2 for cast specimens, and a height to diameter ratio not smaller than 1 for cut specimens.

### 3.2 Marking

Unless a centring device is used, two lines shall be marked along which the load is to be applied. These lines shall be opposite to each other in an axial plane; they can be established using calipers or other appropriate means. The extremities of the two lines shall be connected over each end of the specimen, so as to define clearly the plane of loading. In the case of prismatic and cubic specimens, the load shall be applied on the moulded faces in such a way that the fracture plane will cross the trowelled surface (see figure 1).

### 3.3 Measuring of dimensions

Measure the dimension  $d$  of the specimen in the plane containing the marked lines, to the nearest millimetre, near the ends and at the middle of the specimen. The average of the three measurements shall be taken as the value of  $d$ .

Measure the length  $l$  along each of the two lines of contact, to the nearest millimetre. The average of the two measurements shall be taken as the value of  $l$ .

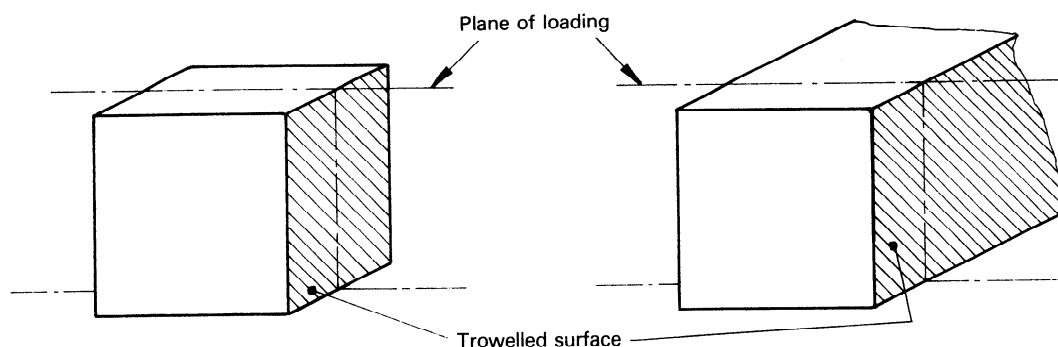

Figure 1 — Plane of loading

1) At present at the stage of draft.

**3.4 Determination of the mass**

Before weighing test specimens which have been cured under water or in a moist atmosphere, wipe off all surplus water. Determine the mass of the specimen with a precision of  $\pm 0,25\%$ . Take note of the moisture condition of the test specimen (for example, oven-dried, air-dried, saturated).

**4 Apparent density**

Calculate the apparent density of the test specimen by dividing its mass, determined in accordance with 3.4, by its volume, calculated from the dimensions determined in accordance with 3.3.

**5 Apparatus**

**5.1 Testing machine**

The testing machine shall conform to regulations for testing

machines for compression tests on concrete as stated in ISO 4012.

**5.2 Packing strips**

Packing strips shall be of plywood or hardboard and shall be used only once. They shall have the following dimensions (see figure 2) :

- width :  $a = 15 \pm 2$  mm
- thickness :  $t = 4 \pm 1$  mm
- length : at least equal to the length of the line of contact of the test specimen.

**5.3 Steel loading pieces**

In tests on cubic or prismatic specimens, it is necessary to place a steel loading piece between the platen of the machine and the

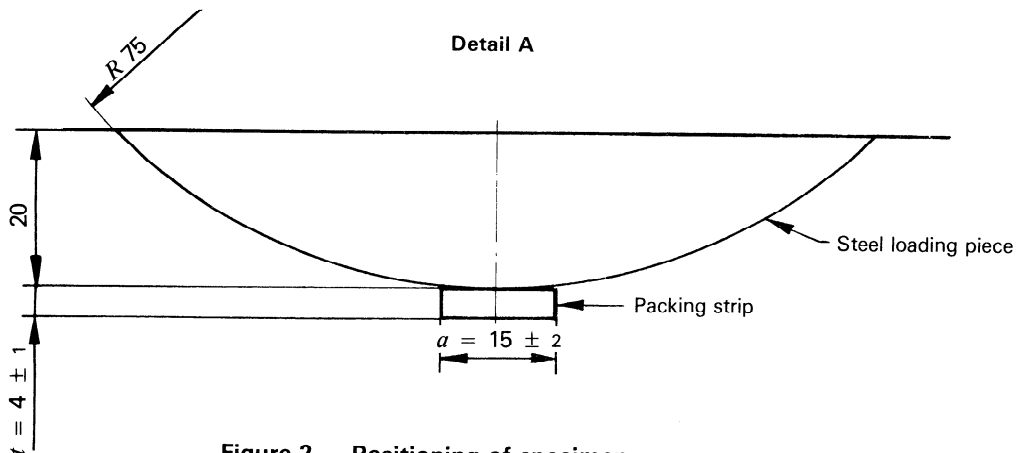
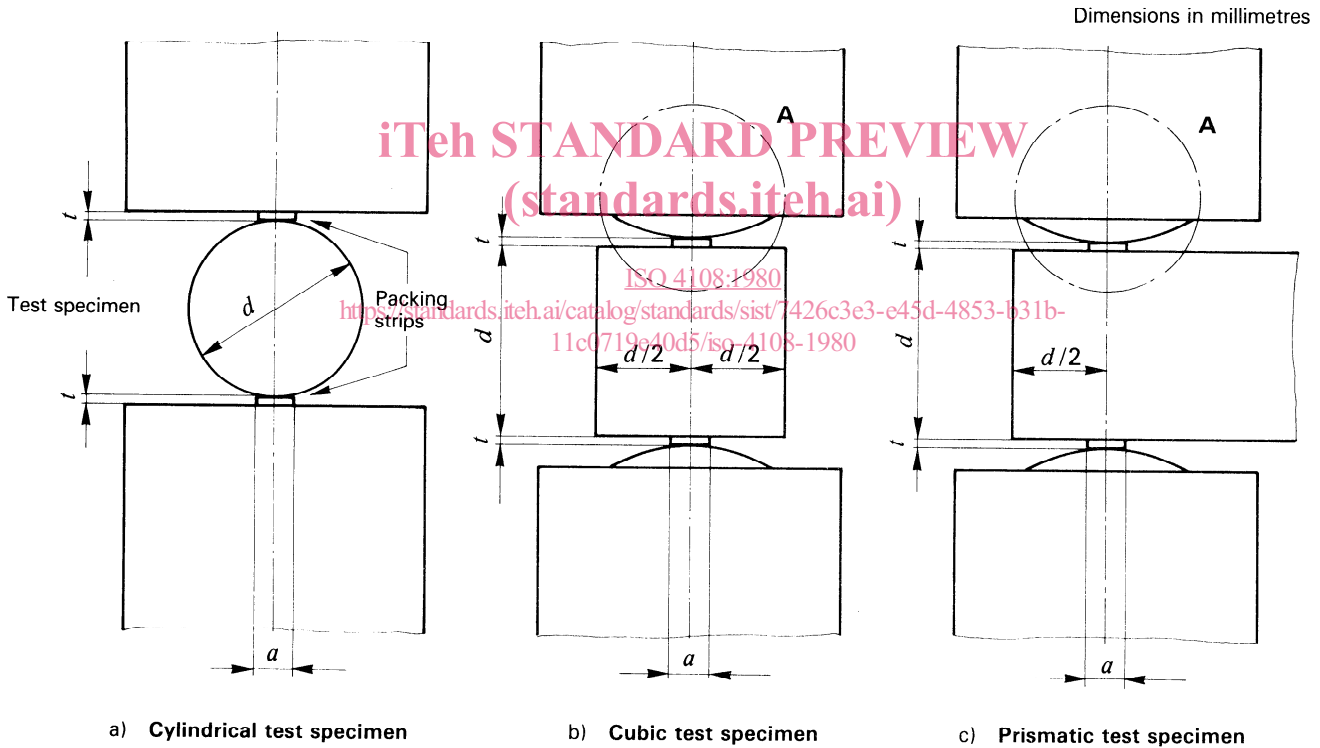

Figure 2 – Positioning of specimen

packing strip. This piece shall not be shorter than the specimen and shall have a cross-section in the shape of a segment of a circle with a radius of 75 mm, so that the load is applied along a line on the surface of the specimen (see figure 2).

## 6 Procedure

### 6.1 Preparation for testing

Wipe clean the bearing surfaces of the testing machine and of the packing strips; remove any loose grit or other material from the surfaces of the test specimen which are to be in contact with the packing strips.

### 6.2 Positioning of the test specimen (see figure 2)

Place the cylindrical test specimen centrally in the testing machine with its axis horizontally between the packing strips in such a manner that the upper packing strip is directly over the lower strip.

Proceed in the same manner for either cubic test specimens or beam ends but making use of the steel loading pieces.

Make sure, either by blocking the spherical head of the machine or by wedging the test specimen, that the latter remains centred when the load is first applied.

### 6.3 Loading

Apply the load continuously and uniformly at a rate of  $0,06 \pm 0,04$  N/(mm<sup>2</sup>.s). Maintain the rate, once adjusted, without any change until failure. The testing time shall be at least 30 s.

Note the maximum load indicated by the testing machine at failure.

## 7 Expression of results

The tensile splitting strength,  $f_{ct}$ , in newtons per square millimetre, is given by the formula

$$f_{ct} = \frac{2F}{\pi \times l \times d}$$

where

$F$  is the maximum load, in newtons;

$l$  is the length of the line of contact of the specimen, in millimetres;

$d$  is the cross-sectional dimension of the specimen, in millimetres, as shown in figure 2.

Express the tensile splitting strength to the nearest 0,05 N/mm<sup>2</sup>.

## 8 Test report

Every report shall refer to this International Standard and shall include the following data :

### 8.1 Data to be given by the producer of the test specimen

#### 8.1.1 Mandatory data

- a) identification of the test specimens;
- b) date of production;
- c) conditions of curing and storage;
- d) required age of the specimen at the time of testing.

#### 8.1.2 Optional data

- e) building project;
- f) part or component of the building;
- g) tensile splitting strength required;
- h) mix data.

### 8.2 Data to be given by the test laboratory

- a) identification and condition of specimen when received;
- b) date of receipt of the specimen;
- c) type and dimensions of the specimen (including indication of whether cut or cast specimen);
- d) curing history;
- e) test date and age of specimen at testing;
- f) apparent density;
- g) maximum load at failure;
- h) tensile splitting strength;
- i) type of fracture;
- j) defects in specimen;
- k) other remarks.

**iTeh STANDARD PREVIEW**  
**(standards.iteh.ai)**

This page intentionally left blank

ISO 4108:1980

<https://standards.iteh.ai/catalog/standards/sist/7426c3e3-e45d-4853-b31b-11c0719e40d5/iso-4108-1980>

**iTeh STANDARD PREVIEW**  
**(standards.iteh.ai)**

This page intentionally left blank

ISO 4108:1980

<https://standards.iteh.ai/catalog/standards/sist/7426c3e3-e45d-4853-b31b-11c0719e40d5/iso-4108-1980>

**iTeh STANDARD PREVIEW**  
**(standards.iteh.ai)**

This page intentionally left blank

ISO 4108:1980

<https://standards.iteh.ai/catalog/standards/sist/7426c3e3-e45d-4853-b31b-11c0719e40d5/iso-4108-1980>