



Designation: D6200 – 01 (Reapproved 2017)

Standard Test Method for Determination of Cooling Characteristics of Quench Oils by Cooling Curve Analysis¹

This standard is issued under the fixed designation D6200; the number immediately following the designation indicates the year of original adoption or, in the case of revision, the year of last revision. A number in parentheses indicates the year of last reapproval. A superscript epsilon (ϵ) indicates an editorial change since the last revision or reapproval.

1. Scope

1.1 This test method describes the equipment and the procedure for evaluation of a quenching oil's quenching characteristics by cooling rate determination.

1.2 This test is designed to evaluate quenching oils in a non-agitated system. There is no correlation between these test results and the results obtained in agitated systems.

1.3 The values in SI units are to be regarded as the standard.

1.3.1 *Exception*—The values in parentheses are provided for information only.

1.4 *This standard does not purport to address all of the safety concerns, if any, associated with its use. It is the responsibility of the user of this standard to establish appropriate safety, health, and environmental practices and determine the applicability of regulatory limitations prior to use.*

1.5 *This international standard was developed in accordance with internationally recognized principles on standardization established in the Decision on Principles for the Development of International Standards, Guides and Recommendations issued by the World Trade Organization Technical Barriers to Trade (TBT) Committee.*

2. Referenced Documents

2.1 *ASTM Standards*:²

D1744 Test Method for Determination of Water in Liquid Petroleum Products by Karl Fischer Reagent (Withdrawn 2016)³

E220 Test Method for Calibration of Thermocouples By Comparison Techniques

E230 Specification and Temperature-Electromotive Force

¹ This test method is under the jurisdiction of ASTM Committee D02 on Petroleum Products, Liquid Fuels, and Lubricants and is the direct responsibility of Subcommittee D02.L0.06 on Non-Lubricating Process Fluids.

Current edition approved Oct. 1, 2017. Published November 2017. Originally approved in 1997. Last previous edition approved in 2012 as D6200-01(2012). DOI: 10.1520/D6200-01R17.

² For referenced ASTM standards, visit the ASTM website, www.astm.org, or contact ASTM Customer Service at service@astm.org. For *Annual Book of ASTM Standards* volume information, refer to the standard's Document Summary page on the ASTM website.

³ The last approved version of this historical standard is referenced on www.astm.org.

(EMF) Tables for Standardized Thermocouples

2.2 *SAE Standards*:⁴

AMS 5665 Nickel Alloy Corrosion and Heat Resistant Bars, Forgings and Rings

2.3 *Japanese Industrial Standards (JIS)*:⁵

JIS K 2242 - 1980 Heat Treating Oil

JIS K 6753 - 1977 Di-2-ethylhexyl Phthalate

3. Terminology

3.1 *Definitions of Terms Specific to This Standard*:

3.1.1 *cooling curve, n*—the cooling curve is a graphical representation of the cooling time (t) - temperature (T) response of the probe (see 7.3). An example is illustrated in Part B of Fig. 1.

3.1.2 *cooling curve analysis, n*—the process of quantifying the cooling characteristics of a heat treating oil based on the temperature versus time profile obtained by cooling a pre-heated metal probe assembly (see Fig. 2) under standard conditions.

3.1.3 *cooling rate curve, n*—The cooling rate curve is obtained by calculating the first derivative (dT/dt) of the cooling time - temperature curve. An example is illustrated in Part B of Fig. 1.

3.1.4 *heat treating oil, n*—a hydrocarbon containing product, often derived from petroleum base stock, that is used to mediate heat transfer between heated metal, such as austenitized steel, to control the microstructure that is formed upon cooling and also control distortion and minimize cracking which may accompany the cooling process.

3.1.5 *quench severity, n*—the ability of a quenching medium to extract heat from a hot metal.⁶

4. Summary of Test Method

4.1 Determine the nickel alloy probe assembly's cooling time versus temperature after placing the assembly in a furnace

⁴ Available from Society of Automotive Engineers (SAE), 400 Commonwealth Dr., Warrendale, PA 15096-0001, http://www.sae.org.

⁵ Available from Japanese Standards Organization (JSA), 4-1-24 Akasaka Minato-Ku, Tokyo, 107-8440, Japan, http://www.jsa.or.jp.

⁶ Boyer, H. E. and Cary, P. R., *Quenching and Distortion Control*, ASM International, Materials Park, OH, 1988, p. 162.

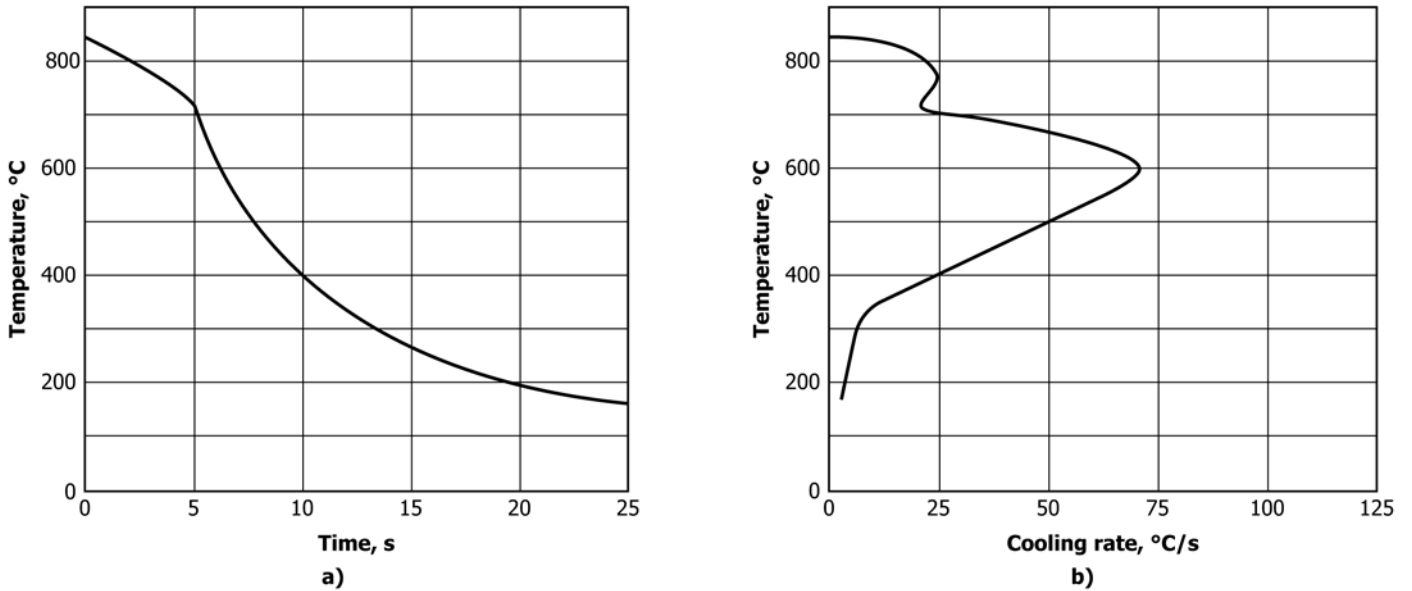
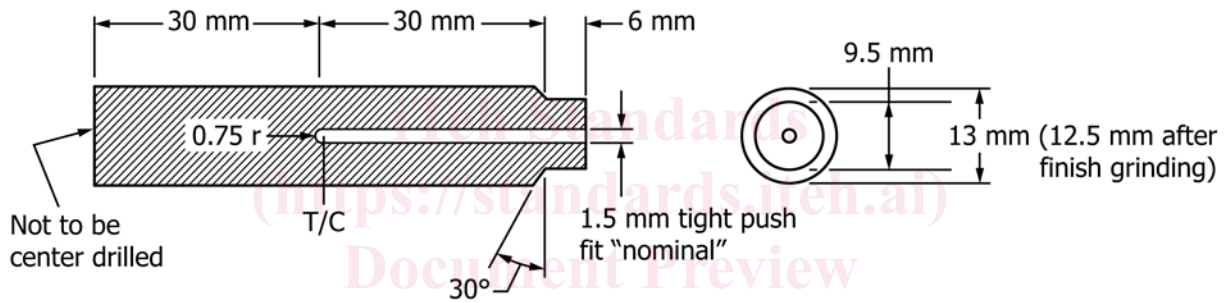

FIG. 1 Typical Temperature/Time and Temperature/Cooling Rate Plots For Test Probe Cooled in a Quenching Oil



(a) Probe details

ASTM D6200-01(2017)

<https://standards.iteh.ai/catalog/standards/sist/3f166a60-b509-43fa-803e-d6e7365c5f24/astm-d6200-012017>

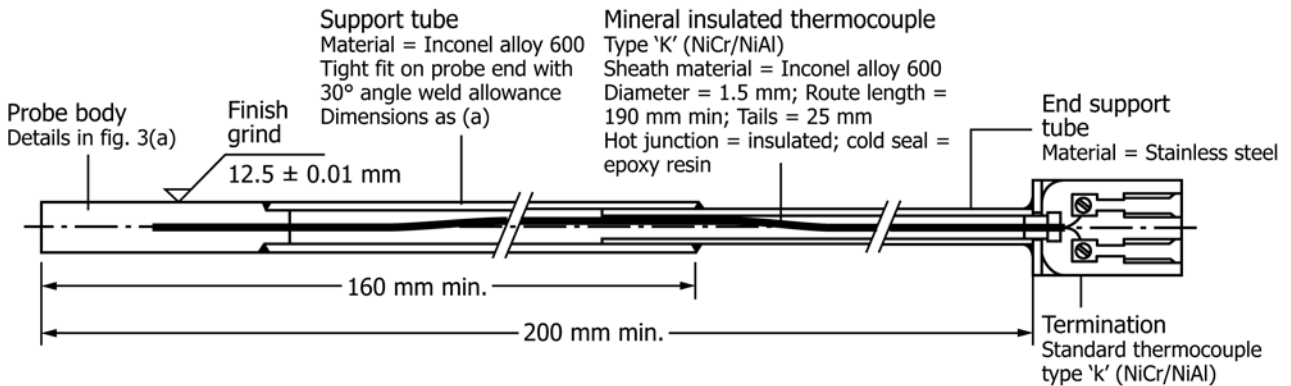

(b) General assembly

FIG. 2 Probe Details and General Probe Assembly

and heating to 850 °C (1562 °F) and then quenching in a heat treating oil. The temperature inside the probe assembly and the cooling times are recorded at selected time intervals to establish a cooling temperature versus time curve. The resulting cooling curve may be used to evaluate quench severity (see Note 1).

NOTE 1—For production testing, the furnace temperature of 815 °C to 857 °C (1500 °F to 1575 °F) may be used.

5. Significance and Use

5.1 This test method provides a cooling time versus temperature pathway which is directly proportional to physical properties such as the hardness obtainable upon quenching of a metal. The results obtained by this test may be used as a guide in heat treating oil selection or comparison of quench severities of different heat treating oils, new or used.

6. Interferences

6.1 The presence of water in a heat treating oil has a major effect upon the results obtained with this test method. Water content of calibration fluids shall be confirmed by Test Method **D1744**. If water is present above 0.01 %, the calibration fluid shall be dried at a minimum temperature of 102°C (216°F) until Test Method **D1744** indicates water content at or below 0.01 %.

7. Apparatus

7.1 *Furnace*—Use a horizontal or vertical electrical resistance tube-type furnace capable of maintaining a constant minimum temperature of 850 °C (1562 °F) over a heated length of not less than 120 mm (4.72 in.) and a probe positioned in the center of the heating chamber. The furnace shall be capable of maintaining the probe's temperature within ± 2.5 °C (4.5 °F) over the specimen length. The furnace, that is, the radiant tube heating media, shall be used with ambient atmosphere.

7.2 *Measurement System*—The temperature-time measurement system shall be a computer based data acquisition system capable of providing a permanent record of the cooling characteristics of each oil sample tested, producing a record of variation in the test probe assembly of temperature with respect to time, and cooling rate with respect to temperature.

7.3 *Probe*—The probe shall be cylindrical, having a diameter of 12.5 mm \pm 0.01 mm (0.492 in. \pm 0.0004 in.) and a length of 60 mm \pm 0.25 mm (2.362 in. \pm 0.01 in.) with a 1.45 mm to 1.65 mm (0.057 in. to 0.065 in.) sheathed Type K thermocouple in its geometric center. The probe shall be made of a nickel alloy 600 (UNS N06600) purchased to SAE Specification AMS 5665 which has a nominal composition of 76.0 % Ni, 15.5 % Cr, 8.0 % Fe, .08 % C, and .25 % max Cu. The probe shall be attached to a support tube with a minimum length of 200 mm (7.874 in.). The thermocouple sheathing and the support tube shall be the same material as the probe (see **Note 2**). See **Fig. 2** for recommended manufacturing details.

NOTE 2—Care must be taken that the probe specimen is not damaged as surface irregularities will influence the results of the test.

7.4 *Transfer Mechanism*—One of the following shall be used to transfer the heated probe from the furnace to the test fluid.

7.4.1 *Automated Transfer Mechanism*—The transfer from the furnace to the oil shall be completed within 3.0 s. Immerse the probe in the center, 0 mm to 5 mm (0 in. to 0.197 in.), of the heat treating oil container to a depth where there is 50 mm \pm 2 mm (1.97 in. \pm 0.08 in.) of fluid above and below the probe when quenched. A mechanical stop shall be used for reproducibility of probe placement.

7.4.2 *Manual Transfer*—If manual transfer is used, the sample container shall be equipped with a fixture to ensure correct placement in the center of the heat treating oil container and to the depth defined in 7.4.1. A timer shall be used to ensure a maximum transfer time of 3.0 s.

7.5 *Sample Container*—A container, preferably a damage-resistant, tall form vessel having an internal diameter of 115 mm \pm 5 mm (4.528 in. \pm 0.197 in.) shall be selected to provide 50 mL (1.97 in.) of fluid above and below the probe when quenched. It is recommended that 2000 mL \pm 50 mL of oil be used. The resulting cooling curve will be dependent on the temperature rise during the quench and on the total fluid volume. Therefore, the cooling curve analysis shall be performed with the same volume of fluid.

7.6 *Oil Temperature Measurement*—Any temperature detection device may be used that is capable of measuring oil temperature to within ± 1 °C (1.8 °F) during drying.

7.7 *Timer*—Graduated in seconds and minutes, and may be part of a computer clock.

8. Reagents and Materials

8.1 *Reference Quenching Fluid*—A reference quenching fluid shall be used for initial and regular system calibration. The primary reference fluid, as described in the Wolfson Engineering Group Specification⁷, exhibits the following cooling characteristics:

Time to cool to 600 °C (1112 °F)	12 s to 14 s
Time to cool to 400 °C (752 °F)	19 s to 21 s
Time to cool to 200 °C (392 °F)	50 s to 55 s
Cooling rate, max	47 °C to 53 °C/s (85 °F to 95 °F/s)
Temperature of the maximum cooling rate	490 °C to 530 °C (914 °F to 986 °F)
Cooling rate at 300 °C (572 °F)	6 °C to 8 °C/s (10.8 °F to 14.4 °F/s)

8.1.1 These characteristics are based on quenching a 2000 mL \pm 50 mL volume of the primary reference fluid in the sample container described in 7.5 according to the procedure outlined in Section 13.

8.1.2 A secondary reference fluid, such as JIS Standards K 2242 and K 6753, may be used, provided that sufficient statistical cooling curve testing has been conducted so that results are traceable to the six cooling characteristics of the primary reference fluid.

8.1.3 The reference fluids shall be stored in a sealed container when not in use and shall be replaced after 200 quenches or two years, whichever is sooner.

8.2 *Cleaning Solvent*—A hydrocarbon solvent that will evaporate at room temperature, leaving no residue (**Warning**—Flammable. Harmful if inhaled.).

8.3 *Polishing Paper*, 600 grit Emery.

8.4 *Cloth*, lintless and absorbent.

9. Cleaning and Conditioning

9.1 *Cleaning Used Probes*—Wipe probe with a lintless cloth or absorbent paper after removal from the oil and prior to

⁷ Available from Wolfson Heat Treatment Centre, Aston University, Aston Triangle, Birmingham B4 7ET, England.