



Designation: ~~D6296 – 98 (Reapproved 2013)~~ **D6296 – 98 (Reapproved 2017)**

Standard Test Method for Total Olefins in Spark-ignition Engine Fuels by Multidimensional Gas Chromatography¹

This standard is issued under the fixed designation D6296; the number immediately following the designation indicates the year of original adoption or, in the case of revision, the year of last revision. A number in parentheses indicates the year of last reapproval. A superscript epsilon (ϵ) indicates an editorial change since the last revision or reapproval.

1. Scope

1.1 This test method provides for the quantitative determination of total olefins in the C_4 to C_{10} range in spark-ignition engine fuels or related hydrocarbon streams, such as naphthas and cracked naphthas. Olefin concentrations in the range from ~~0.2 to 5.0 liquid-volume~~ 0.2 liquid-volume % or mass % to 5.0 liquid-volume % or mass %, or both, can be determined directly on the as-received sample whereas olefins in samples containing higher concentrations are determined after appropriate sample dilution prior to analysis.

1.2 This test method is applicable to samples containing alcohols and ethers; however, samples containing greater than 15 % alcohol must be diluted. Samples containing greater than 5.0 % ether must also be diluted to the 5.0 % or less level, prior to analysis. When ethyl-*tert*-butylether is present, only olefins in the C_4 to C_9 range can be determined.

1.3 This test method can not be used to determine individual olefin components.

1.4 This test method can not be used to determine olefins having higher carbon numbers than C_{10} .

NOTE 1—Precision was determined only on samples containing MTBE and ethanol.

1.5 The values stated in SI units are to be regarded as standard. No other units of measurement are included in this standard.

1.6 *This standard does not purport to address all of the safety concerns, if any, associated with its use. It is the responsibility of the user of this standard to establish appropriate safety, health, and environmental practices and determine the applicability of regulatory limitations prior to use.*

1.7 *This international standard was developed in accordance with internationally recognized principles on standardization established in the Decision on Principles for the Development of International Standards, Guides and Recommendations issued by the World Trade Organization Technical Barriers to Trade (TBT) Committee.*

2. Referenced Documents

2.1 *ASTM Standards:*²

[D1319 Test Method for Hydrocarbon Types in Liquid Petroleum Products by Fluorescent Indicator Adsorption](#)

[D4052 Test Method for Density, Relative Density, and API Gravity of Liquids by Digital Density Meter](#)

[D4307 Practice for Preparation of Liquid Blends for Use as Analytical Standards](#)

[D4815 Test Method for Determination of MTBE, ETBE, TAME, DIPE, tertiary-Amyl Alcohol and \$C_1\$ to \$C_4\$ Alcohols in Gasoline by Gas Chromatography](#)

[D5599 Test Method for Determination of Oxygenates in Gasoline by Gas Chromatography and Oxygen Selective Flame Ionization Detection](#)

3. Terminology

3.1 *Definitions of Terms Specific to This Standard:*

3.1.1 *trap, n*—a device utilized to selectively retain specific portions (individual or groups of hydrocarbons or oxygenates) of the test sample and to release the retained components by increasing the trap temperature.

¹ This test method is under the jurisdiction of ASTM Committee D02 on Petroleum Products, Liquid Fuels, and Lubricants and is the direct responsibility of Subcommittee D02.04.0L on Gas Chromatography Methods.

Current edition approved Oct. 1, 2013; Oct. 1, 2017. Published October 2013; November 2017. Originally approved in 1998. Last previous edition approved in 2008; 2013 as D6296 – 98(2008); (2013). DOI: ~~10.1520/D6296-98R13~~ 10.1520/D6296-98R17.

² For referenced ASTM standards, visit the ASTM website, www.astm.org, or contact ASTM Customer Service at service@astm.org. For *Annual Book of ASTM Standards* volume information, refer to the standard's Document Summary page on the ASTM website.

3.2 Acronyms:

3.2.1 *ETBE*—ethyl-*tert*-butylether.

3.2.2 *MTBE*—methyl-*tert*-butylether.

4. Summary of Test Method

4.1 A reproducible ~~0.2- μ L~~ 0.2 μ L volume of a representative sample, or a dilution thereof, is introduced into a computer controlled gas chromatographic system³ consisting of a series of columns, traps, and switching valves operating at various temperatures. The valves are actuated at predetermined times to direct portions of the sample to appropriate columns and traps. The sample first passes through a polar column that retains C₁₂+ hydrocarbons, all aromatics, C₁₁+ olefins, and some alcohols, all of which are subsequently backflushed to vent. The fraction eluting from the polar column, which contains C₁₁ and lower boiling saturated hydrocarbons as well as decene and lower boiling olefins, enters an ether/alcohol trap where the ethers and alcohols are selectively retained and also subsequently backflushed. The fraction eluting from the ether/alcohol trap, which consists of C₁₁ and lower boiling saturated hydrocarbons and the olefins, enters an olefin trap. The olefins are selectively retained while the saturated hydrocarbons elute, pass through a nonpolar column, and are detected by a flame ionization detector (FID). When the saturated hydrocarbons have completely eluted to the FID, the nonpolar column oven is cooled and the olefins, which have been retained on the olefin trap, are desorbed by heating. The desorbed olefins enter and elute from the nonpolar column, which is temperature programmed to separate the olefins by boiling point, and are detected by the FID.

NOTE 2—Separation of olefins by boiling point is necessary for the calculation of the volume % of the olefins because the density of low boiling olefins differs from that of high boiling olefins and, therefore, a density correction must be applied.

4.2 Quantitation of the detected olefin peak areas to provide volume % or mass %, or both, is accomplished through the use of an external standard followed by the application of flame ionization detector response factors. The quantitation also takes into consideration the baseline compensation, sample dilution, and density corrections.

5. Significance and Use

5.1 The quantitative determination of olefins in spark-ignition engine fuels is required to comply with government regulations.

5.2 Knowledge of the total olefin content provides a means to monitor the efficiency of catalytic cracking processes.

5.3 This test method provides better precision for olefin content than Test Method **D1319**. It also provides data in a much shorter time, approximately 20 min following calibration, and maximizes automation to reduce operator labor.

5.4 This test method is not applicable to M85 or E85 fuels, which contain 85 % methanol and ethanol, respectively.

6. Interferences

6.1 Some types of sulfur-containing compounds are irreversibly absorbed in the olefin and oxygenate traps ultimately reducing the trap capacity. However, a variety of spark-ignition engine fuels have been analyzed without significant performance deterioration of these traps.

6.2 Commercial dyes used to distinguish between grades and types of spark-ignition engine fuels have not been found to interfere with this test method.

6.3 Commercial detergent additives utilized in spark-ignition engine fuels have not been found to interfere with this test method.

6.4 Dissolved water in spark-ignition engine fuels has not been found to interfere with this test method. Free water must be removed using anhydrous sodium sulfate or other drying agent to permit injection of accurate sample volumes.

7. Apparatus

7.1 The complete system used to obtain the precision data is comprised of a computer controlled gas chromatograph, automated sample injector, computer software, and specific hardware modifications. These modifications include columns, traps, and valves which are described as follows and in Section 8. **Fig. 1** illustrates a typical flow diagram and component configuration. Other configurations, components, or conditions may be utilized provided they are capable of separating the olefins and producing a precision that is equivalent, or better, than that shown in the table of precision data.

7.2 *Gas Chromatograph*, dual column, temperature programmable over a range from ~~60~~60 °C to ~~160~~160 °C at approximately ~~20~~20 °C/min, equipped with heated flash vaporization sample inlets, a single flame ionization detector, necessary flow controllers, and computer control.

³ The sole source of supply of apparatus known to the committee at this time, the AC FTO Analyzer, is AC Analytical Controls, Inc., 3494 Progress Dr., Bensalem, PA 19020. If you are aware of alternative suppliers, please provide this information to ASTM Headquarters. Your comments will receive careful consideration at a meeting of the responsible technical committee,¹ which you may attend.

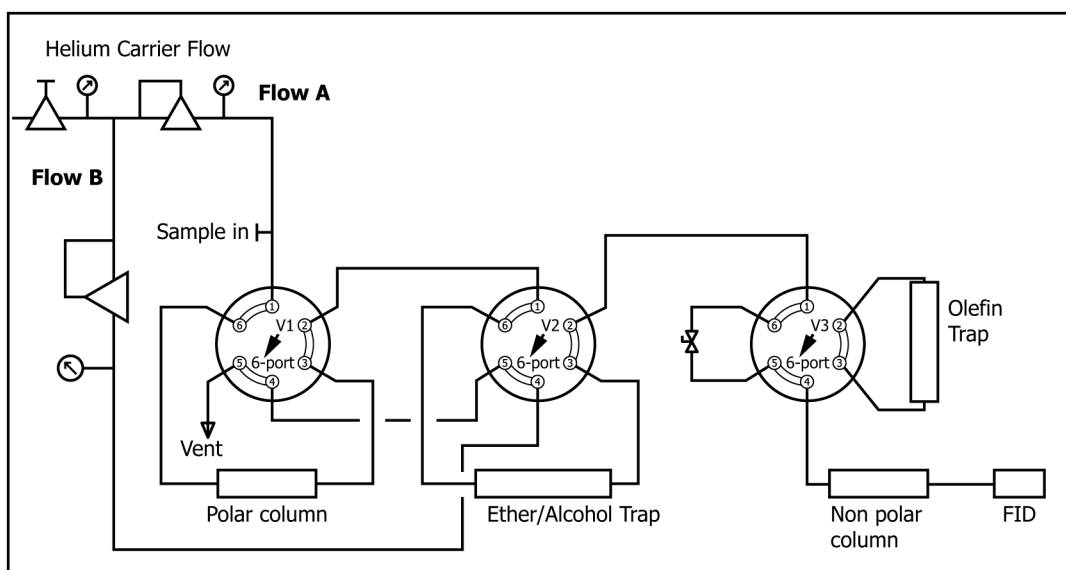

FIG. 1 Typical Flow Diagram and Component Configuration

7.3 *Sample Introduction System*—*System*, manual or automatic, capable of injecting a reproducible $0.2 \pm 0.2 \mu\text{L}$ injection volume of liquid. The total injected sample must be introduced to the chromatographic system, thus excluding the use of split injections or carrier gas purging of the inlet septum. An auto injector is recommended but optional. The precision data was obtained using an automated sample injector.

7.4 *Gas Flow and Pressure Controllers*—*Controllers*, with adequate precision to provide reproducible flow and pressure of helium to the chromatographic system, and hydrogen and air for the flame ionization detector. Control of air flow for rapid cooling of specific system components and for automated valve operation is also required.

7.5 *Electronic Data Acquisition System*, must meet or exceed the following specifications (see Note 3):

7.5.1 Capacity for 150 peaks for each analysis,

7.5.2 External standard calculation of selected peaks with response factors and background correction,

7.5.3 Noise and spike rejection capability,

7.5.4 Sampling rate for fast ($<4.0 \text{ s}$) peaks ($>5 \text{ Hz}$ to give 20 points across peak),

7.5.5 Peak width detection for narrow and broad peaks, and

7.5.6 Perpendicular drop.

NOTE 3—Standard supplied software is typically satisfactory.

7.6 *Gas Purifiers*, to remove moisture and oxygen from helium, moisture and hydrocarbons from hydrogen, and moisture and hydrocarbons from air.

7.7 *Balance*, analytical, capable of weighing 0.0001 g.

7.8 *Glassware*:

7.8.1 *Vial*, autosampler, with caps and including a cap crimper (required when the recommended optional autosampler is used).

7.8.2 *Pipette*, Pasteur, disposable, with bulb.

7.8.3 *Pipette*, volumetric, graduated in 0.01 mL increments, 1 mL and 2 mL capacity.

7.8.4 *Pipette*, total volume, $1, 3, 5, 10, 20$ and 25 mL , $1 \text{ mL}, 3 \text{ mL}, 5 \text{ mL}, 10 \text{ mL}, 20 \text{ mL},$ and 25 mL capacity.

7.9 *Septa*, polytetrafluoroethylene (PTFE) lined for injector.

7.10 *Temperature Controllers of System Components*—The independent temperature control of two columns and two traps, column switching valves, and sample lines is required. All system components that contact the sample must be heated to a temperature that will prevent condensation of any sample component. Table 1 lists the system components and operating temperature (see Note 4). Some of the components require isothermal operation, some require rapid heating and cooling, while one requires reproducible temperature programming. The indicated temperatures are typical; however, the control systems utilized must have the capability of operating at temperatures $\pm 20^\circ$ of those indicated to accommodate specific systems. Temperature control may be by any means that will meet the requirements of Table 1.

NOTE 4—The system components and temperatures listed in Table 1 and Section 8 are specific to the analyzer used to obtain the precision data. Other columns and traps that can adequately perform the required separations are also satisfactory but may require different temperatures.

TABLE 1 Temperature Control Ranges of System Components

| Component | Typical Operating | Heating Time, min, | | Cooling Time, min, | |
|----------------------------|-----------------------|--------------------|-----|------------------------------------|-----|
| | Temperature Range, °C | max | max | max | max |
| Polar column | 60 to 160 | | | | |
| Nonpolar column | 60 to 160 | | | | |
| Nonpolar column | 60 to 160 | | | temperature programmed, ~20 °C/min | |
| Ether/alcohol trap | 120 to 280 | 1 | | | 5 |
| Olefin trap | 155 to 280 | 1 | | | 5 |
| Column switching | 100 | | | isothermal | |
| Valves | | | | | |
| Sample lines | 100 | | | isothermal | |

7.11 *Valves, Column, and Trap Switching*—*Switching*—automated 6-port rotary valves are recommended. The valves must be intended for gas chromatographic usage and meet the following requirements:

7.11.1 The valves must be capable of continuous operation at operating temperatures that will prevent sample condensation.

7.11.2 The valves must be constructed of materials that are nonreactive with the sample under analysis conditions. Stainless steel, PFA, and Vespel⁴ are satisfactory.

7.11.3 The valves must have a small internal volume but offer little restriction to carrier gas flow under analysis conditions.

7.12 *Valves, Air*, to control pressurized air for ether/alcohol and olefin trap cooling; 3-port automated valves are recommended.

NOTE 5—New valves, tubing, columns, traps, and other materials that contact the sample or gasses may require conditioning prior to operation in accordance with the manufacturer's instructions.

8. Reagents and Materials

8.1 *Air*, compressed, 10 mg/mg/kg/kg each of total hydrocarbons and H₂O. (**Warning**—Compressed gas under high pressure that supports combustion.)

8.2 *Helium*, 99.999 % pure, 0.1 0.1 mg/mg/kg/kg H₂O (**Warning**—Compressed gas under high pressure.)

8.3 *Hydrogen*, 99.999 % pure, 0.1 0.1 mg/mg/kg/kg H₂O (**Warning**—Extremely flammable gas under high pressure.)

8.4 *2,2,4-trimethylpentane (isooctane)*, (*isooctane*), 99.99 % pure (**Warning**—Flammable. Harmful if inhaled.)

8.5 *Columns and Traps (System Components)*—*Components*—This test method requires the use of two chromatographic columns and two traps (see **Note 4**). Each system component is independently temperature controlled as described in **7.10** and **Table 1**. Refer to **Fig. 1** for the location of the components in the system. The following list of columns and traps contains guidelines that are to be used to judge suitability.

8.5.1 *Polar Column*—At a temperature of ~~160°C, 160 °C~~, this column must retain all aromatic components in the sample and elute all nonaromatic components boiling below ~~200°C, 200 °C~~, which includes decene and lower boiling olefins, within 2 min after sample injection.

8.5.1.1 This column must elute all aromatics and other components retained from **8.5.1** within 8 min of when it is backflushed.

8.5.2 *Ether/Alcohol Trap*—At a temperature of ~~140°C, 140 °C~~, this trap must retain alcohols and ethers and elute all non-oxygenates boiling below ~~200°C, 200 °C~~ within ~~4.5, 4.5 min~~ to ~~5.0 min~~ ~~5.0 min~~ after sample injection.

8.5.2.1 At a temperature of ~~280°C, 280 °C~~, this trap must elute all retained components.

8.5.3 *Olefin Trap*—Within a temperature range from ~~140°C, 140 °C~~ to ~~165°C, 165 °C~~, this trap must quantitatively retain (trap) all olefins in the C₄ to C₁₀ range for at least 10 min after sample injection while eluting all non-olefin components boiling below ~~200°C, 200 °C~~.

8.5.3.1 At a temperature of ~~280°C, 280 °C~~, this trap must quantitatively elute all trapped olefins.

8.5.4 *Nonpolar Column*—At a temperature of ~~160°C, 160 °C~~, this column must elute paraffins and naphthenes through C₁₁ within 2 min.

8.5.4.1 This column must distribute the C₄ through C₁₀ olefins by carbon number when temperature programmed from ~~60°C, 60 °C~~ to ~~160°C, 160 °C~~ at approximately ~~20°C/min, 20 °C/min~~.

8.6 *Set Up Mixtures*—Two qualitative synthetic mixtures containing *isooctane* and ethers are required to verify that all instrument components, temperatures, and cut times are satisfactory to produce accurate analyses and to aid in making operating adjustments as columns and traps age. The composition of these mixtures and approximate component concentrations are shown in **Table 2**. The mixtures may be purchased or prepared according to Practice **D4307**. (**Warning**—Flammable. Harmful if inhaled.)

8.7 *Calibration Standards*—Quantitative synthetic mixtures of pure hydrocarbons and ethers (**Warning**—Flammable. Harmful if inhaled) are required to verify that the required component separation is being achieved, to determine the retention time of the olefins by carbon number, and to determine the response factor on the FID for the olefins. Examples of two mixtures, including

⁴ PFA and Vespel are trademarks of E.I. DuPont de Nemours and Co.

TABLE 2 Set Up Mixtures

| Mixture No. | Component | Approximate Concentrations, mass % |
|-------------|--|------------------------------------|
| 1 | methyl- <i>tert</i> -butylether (MTBE) | 5 |
| | isooctane | 95 |
| 2 | ethyl- <i>tert</i> -butylether (ETBE) | 5 |
| | isooctane | 95 |

densities of individual components, are shown in [Table 3](#) and [Table 4](#).⁵ Calibration Standard 1 is used for all samples except those that contain ETBE and Calibration Standard 2 is used for samples containing ETBE. When the oxygenate composition of samples is unknown, it can be determined using Test Method [D4815](#), [D5599](#), or other test methods. Mixtures may be purchased or prepared according to Practice [D4307](#). The actual concentration levels are not critical but must be accurately known. Determine the density of the calibration standard by Test Method [D4052](#) or other test method.

8.8 *Quality Control Sample*, used to routinely monitor the operation of the chromatographic system and to verify that reported concentrations are within the precision of the test method. A sample or samples that are similar in composition to samples typically analyzed may be designated as the quality control (QC) samples. When samples to be analyzed contain C₄ and C₅ olefins, the QC samples must contain these to monitor olefin trap capacity. Each QC sample must be of sufficient volume to provide an ample supply for the intended period of use, and it must be homogeneous and stable under the anticipated storage conditions.

9. Preparation and Setup of Apparatus

9.1 Assemble the analyzer system (gas chromatograph with independent temperature controlled components) as shown in [Fig. 1](#) or with an equivalent flow system. If using a commercial system, install, place the system in service, and optimize the system in accordance with the manufacturer's instructions.

NOTE 6—Commercial systems will have all parameters predetermined and accessible through the software. Other constructed systems will require experimentation and optimization of parameters to achieve the required separation and precision.

9.2 Impurities in the helium carrier gas, hydrogen, or air will have a detrimental effect on the performance of the columns and traps. Therefore, install efficient purifiers in the gas lines as close to the system as possible and use good quality gases. The helium and hydrogen gas connection lines shall be made of metal. Check that all gas connections, both exterior and interior to the system, are leak tight.

9.3 Verify that the ether/alcohol trap conditions satisfactorily retain ethers. Analyze Set Up Mixture 1 or 2, depending on whether samples contain MTBE or ETBE, using a method to set the switching valves so that only the nonpolar column and ether/alcohol trap are in the flow path. Determine the elution time of the MTBE (or ETBE). The ether/alcohol trap conditions are satisfactory if the ether peak begins to elute after ~~5.5 min~~ **5.5 min** and the peak shows a steep frontal portion. If the ether peak begins to elute earlier or the frontal is not steep, decrease the temperature of the ether/alcohol trap and reoptimize the system.

NOTE 7—If the oxygenate composition is unknown, the sample will require analysis by Test Method [D4815](#), [D5599](#), or other test methods. If it is found that ETBE is present, only C₄ through C₉ olefins can be determined.

9.4 Optimize the olefin trap temperature by analyzing Calibration Standard 1 or 2 as described in [10.3](#), depending on whether samples contain MTBE or ETBE. A typical chromatogram is shown in [Fig. 2](#). Verify that undecane is completely eluted before 10 min while pentene is quantitatively (see [Note 8](#)) retained. If the undecane has a longer retention time, the olefin trap temperature must be increased. If pentene is not being quantitatively retained, the olefin trap temperature must be decreased. Adjust the olefin trap temperature as necessary, and reanalyze the calibration standard until the above conditions are met.

NOTE 8—As compared to the precision statement (see [Table 5](#)).

9.5 Analyze the quality control sample, see [8.8](#). Verify that results are consistent with those previously obtained and that C₄ and C₅ olefins are quantitatively (see [Note 8](#)) retained by the olefin trap. If C₄ and C₅ olefins are not quantitatively retained, reoptimize the olefin trap temperature (see [9.4](#)).

9.5.1 Reoptimize the system (see [9.1](#)) whenever the QC sample results do not conform to those expected.

10. Procedure

10.1 *Sample Preparation*—Because the ether/alcohol and olefin traps have specific capacities that must not be exceeded, some samples will need to be diluted to stay within the working concentration range limits of the system.

⁵ ASTM publication DS 4A, *Physical Constants of Hydrocarbons*, and ASTM publication DS 4B, *Physical Constants of Hydrocarbons for Oxygenates*, ASTM International, W. Conshohocken, PA.

TABLE 3 Calibration Standard 1 Containing MTBE

| Component | Density, kg/L | Mass % | Volume % |
|------------------|---------------|--------|----------|
| Pentene | 0.6452 | 1.00 | 1.09 |
| Hexene | 0.6763 | 1.00 | 1.04 |
| Heptene | 0.7009 | 1.00 | 1.00 |
| Octene | 0.7186 | 1.00 | 0.98 |
| Nonene | 0.7329 | 1.00 | 0.96 |
| Decene | 0.7440 | 1.00 | 0.94 |
| Undecane | 0.7438 | 1.00 | 0.94 |
| Dodecane | 0.7521 | 1.00 | 0.93 |
| <i>isooctane</i> | 0.6985 | 87.00 | 87.41 |
| MTBE | 0.7451 | 5.00 | 4.71 |
| Total | | 100.00 | 100.00 |

TABLE 4 Calibration Standard 2 Containing ETBE

| Component | Density, kg/L | Mass % | Volume % |
|-----------------------------|-------------------|------------------|------------------|
| Pentene | 0.6452 | 1.00 | 1.09 |
| Hexene | 0.6763 | 1.00 | 1.04 |
| Heptene | 0.7009 | 1.00 | 1.00 |
| Octene | 0.7186 | 1.00 | 0.98 |
| Nonene | 0.7329 | 1.00 | 0.96 |
| Decene | 0.7440 | 1.00 | 0.94 |
| Decane | 0.7335 | 1.00 | 0.95 |
| Undecane | 0.7438 | 1.00 | 0.94 |
| Dodecane | 0.7521 | 1.00 | 0.93 |
| <i>isooctane</i> | 0.6985 | 86.00 | 86.45 |
| <i>isooctane</i> | 0.6985 | 86.00 | 86.45 |
| ETBE | 0.7431 | 5.00 | 4.72 |
| Total | | 100.00 | 100.00 |

10.1.1 Generally, the total olefin concentration must be lower than 5 %. When relatively large amounts of C₄ and C₅ olefins are present, a lower final concentration is required. In addition, the maximum total ether concentration is limited to 5 %. When any of these conditions is exceeded, a dilution of the sample is required prior to analysis.

10.2 Samples are diluted using *isooctane* as a diluent. Fig. 3 is a Sample Dilution Decision Diagram that shows examples of dilutions that can be used to obtain appropriate dilution for specific samples. Other dilutions may be necessary depending on the capacity of the olefin trap as determined by monitoring breakthrough (see Note 9) of olefins using the QC sample. Bring samples and calibration mixture to ambient temperature prior to dilution during sample preparation.

NOTE 9—Breakthrough can be recognized in the chromatogram by the signal not returning to baseline within the first ~~10 min~~ 10 min.

10.2.1 To prepare dilutions, tare to the nearest ~~0.1 mg~~ 0.1 mg, a glass container that can be sealed, preferably with a polyethylene screw cap or equivalent, and that is large enough to contain both the specimen and ~~*isooctane*~~ *isooctane*. Pipette a minimum of ~~1 mL~~ 1 mL of sample into the container and reweigh. Pipette a sufficient volume of *isooctane* into the container to obtain the desired dilution ratio. For example, if a 1:3 dilution is desired, pipette ~~5 mL~~ 5 mL of sample followed by ~~15 mL~~ 15 mL of ~~*isooctane*~~ *isooctane*. Calculate a dilution factor:

$$D_{dil} = \frac{V_{sam}}{V_{sam} + V_{dil}} \quad (1)$$

where:

- D_{dil} = dilution factor,
- V_{sam} = volume of sample added, mL, and
- ~~V_{dil} = volume of *isooctane* diluent, mL.~~
- V_{dil} = volume of *isooctane* diluent, mL.

10.2.2 Calculate the density of the sample to three decimal places:

$$D = \frac{M}{V} \quad (2)$$

where:

- D = density, kg/L,
- M = mass of sample pipetted, g, and
- V = volume of sample pipetted, mL.

10.3 *Sample Analysis*—Load the necessary system set-point conditions, which include initial system component temperatures, times at which column and trap temperatures are changed, the initial positions of switching valves, and times when valve switches occur (see Note 6).