



## Designation: **E803–91 (Reapproved 2013) E803 – 17**

# Standard Test Method for Determining the $L/D$ Ratio of Neutron Radiography Beams<sup>1</sup>

This standard is issued under the fixed designation E803; the number immediately following the designation indicates the year of original adoption or, in the case of revision, the year of last revision. A number in parentheses indicates the year of last reapproval. A superscript epsilon ( $\epsilon$ ) indicates an editorial change since the last revision or reapproval.

## 1. Scope-~~Scope~~\*

1.1 This test method defines an empirical technique for the measurement of the effective collimation ratio,  $L/D$ , of neutron radiography beams. The technique is based upon analysis of a neutron radiographic image and is independent of measurements and calculations based on physical dimensions of the ~~collimator~~ collimation system. The values derived by this technique should be more accurate than those based on physical measurements, particularly for poorly defined apertures.

1.2 This test method covers both the manufacture and use of the device to measure  $L/D$  ratios.

1.3 Neutron images for this method can be produced on radiographic film using an appropriate conversion screen as detailed in Guide E748 or a CR screen with appropriate neutron converter. The method has not been validated with images produced by digital detector arrays.

1.4 This test method only applies to neutron beam lines with cold or thermal neutron spectrums.

1.5 The values stated in SI units are to be regarded as standard.

1.6 *This standard does not purport to address all of the safety concerns, if any, associated with its use. It is the responsibility of the user of this standard to establish appropriate safety, health, and environmental practices and determine the applicability of regulatory limitations prior to use.*

1.7 *This international standard was developed in accordance with internationally recognized principles on standardization established in the Decision on Principles for the Development of International Standards, Guides and Recommendations issued by the World Trade Organization Technical Barriers to Trade (TBT) Committee.*

## 2. Referenced Documents

2.1 *ASTM Standards:*<sup>2</sup>

E748 Guide for Thermal Neutron Radiography of Materials E803-17

E1316 Terminology for Nondestructive Examinations

## 3. Summary of Test Method

3.1 Determination of neutron beam  $L/D$  ratio (length of the beam line divided by the diameter of the aperture) using the NU (no umbra) technique<sup>3</sup> is accomplished by radiographing the NU device with the neutron beam to be measured and subsequently analyzing the radiograph resulting image by one of three methods. Each of the three methods is based upon the determination of that point at which the umbral shadow width reaches zero. See Fig. 1. A key feature of the NU technique is that the neutron  $L/D$  can be determined accurately without the need for expensive instrumentation. Neutron radiography practices are discussed in Practices radiography method is discussed in Guide E748 and the terms are defined in Terminology E1316.

## 4. Significance and Use

4.1 The quality of a neutron radiographic image is dependent upon many factors. The  $L/D$  ratio is one of those factors and constitutes a numerical definition of the geometry of the neutron beam. The  $L/D$  ratio required for a specific neutron radiographic

<sup>1</sup> This test method is under the jurisdiction of Committee E07 on Nondestructive Testing and is the direct responsibility of Subcommittee E07.05 on Radiology (Neutron) Method.

Current edition approved June 1, 2013/Nov. 1, 2017. Published June 2013/November 2017. Originally approved in 1986. Last previous edition approved in 2008/2013 as E803 – 91 (2008) (2013). DOI: 10.1520/E0803-91R13-10.1520/E0803-17.

<sup>2</sup> For referenced ASTM standards, visit the ASTM website, www.astm.org, or contact ASTM Customer Service at service@astm.org. For Annual Book of ASTM Standards volume information, refer to the standard's Document Summary page on the ASTM website.

<sup>3</sup> Newacheck, R. L., and Underhill, P. E., "The NU Method for Determining  $L/D$  Ratio Of Neutron Radiography Facilities," Aerotest Operations, Inc., Report A.O. 77-27, June 1977.

\*A Summary of Changes section appears at the end of this standard

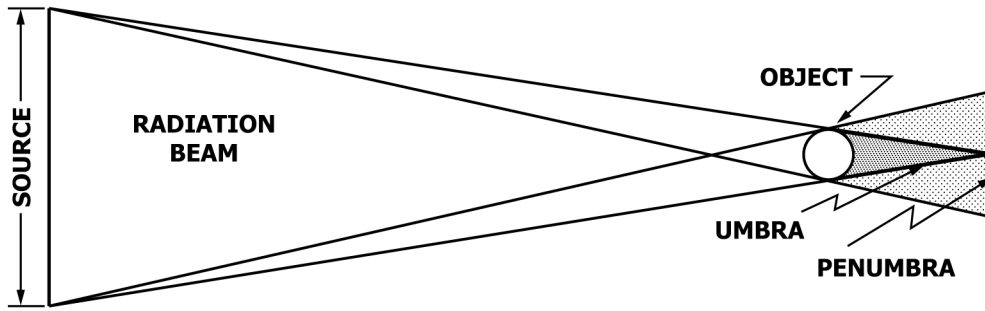

FIG. 1 Diagram of Zero Umbra Image Configuration

examination is dependent upon the thickness of the specimen and the physical characteristics of the particular element of interest. Use of this test method allows the radiographer and the user to determine and periodically check/measure the effective collimation ratio.

5. Apparatus

5.1 *The NU Device* (see Fig. 2(a) and (b), and Fig. 3) employs neutron absorbing rods positioned at various distances from the image plane. In practice this device consists of cadmium and nylon rods located in V-grooves accurately machined in the surface of an aluminum channel section set at a  $45 \pm 1/4^\circ$  angle to the side support plate. Near the image plane end the V-grooves are machined on 0.283-cm centers. After 21 V-grooves, counting one on the end, the grooves are machined on 0.707-cm centers to the source end. The 0.64-mm diameter cadmium and nylon rods are laid into the V-grooves and secured with neutron transparent adhesive tape. The aluminum channel is supported by side plates to maintain the  $45 \pm 1/4^\circ$  angle relative to the image plane. While cadmium rods with diameters other than 0.64 mm may be used, the exact rod diameter/LD must be known and the depth of the V-grooves must be adjusted accordingly. These nylon rods are not used in diameter/LD calculations, nor do they detract from the function of the device, and so are considered optional.

5.2 A single A unit or B unit as shown in Fig. 2(b) is(b) and Fig. 3 can be used for LD values expected to be less than 150-150, while multiple device segments can be used in combination to measure larger LD ratios. Alternately, a single A or B unit used with appropriate spacers may be used to accommodate a wide range of LD values-values when using the methods described in 7.1 or 7.3 to establish the collimation ratio.

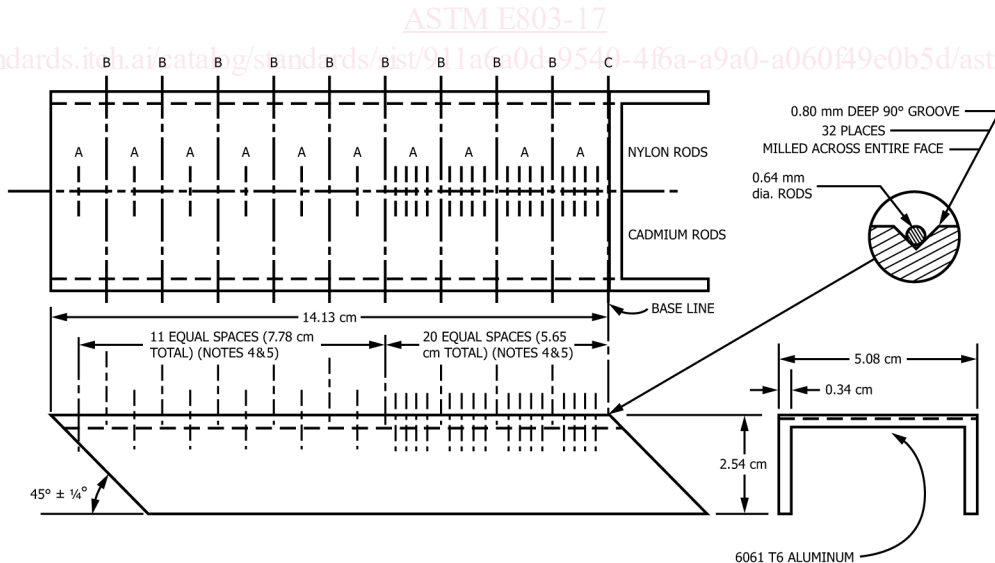

- NOTE 1—Rods at “A” positions are 1 cm each side of center line (22 ea.)
- NOTE 2—Rods at “B” positions are 2 cm each side of center line (9 ea.)
- NOTE 3—Rods at “C” positions are 2.5 cm each side of center line (1 ea.)
- NOTE 4—All dimensions from base line to reduce accumulative errors
- NOTE 5—Rod arrangement shown for single system device. For an add-on device, to form a double system, extend the 11 spaces for 7.78 cm to 19 spaces for 13.43 cm and eliminate the close spacing (20 for 5.65 cm)
- NOTE 6—Rods held tightly in position with one layer of transparent tape

FIG. 2 (a) Support Channel Subassembly with Rod Spacing

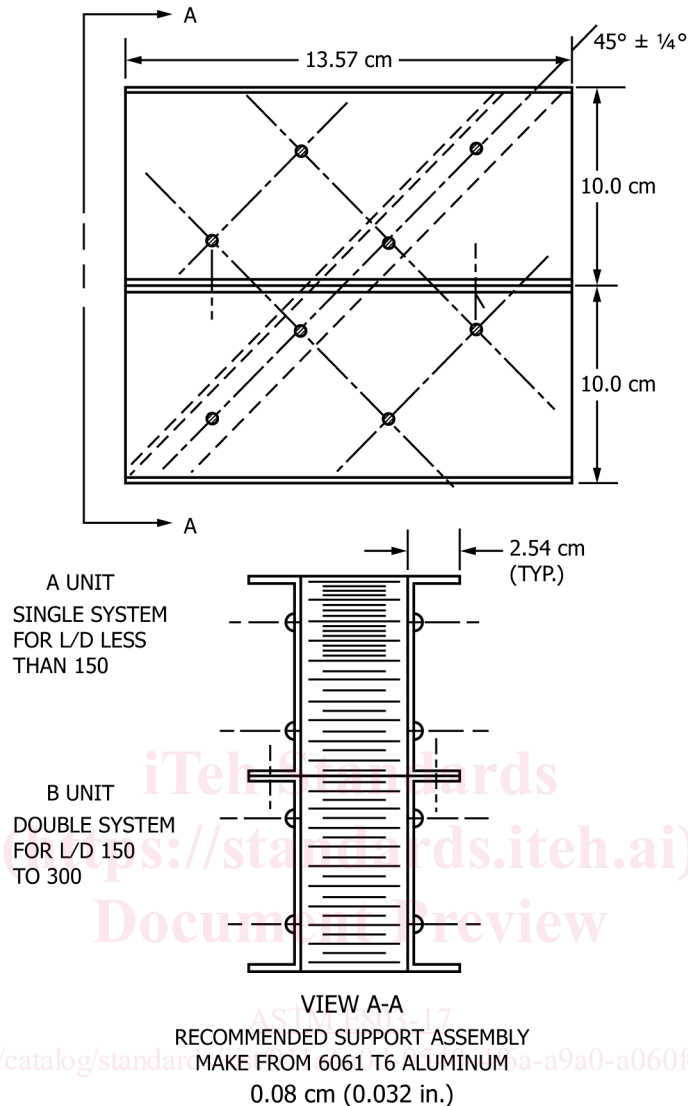

FIG. 2 (b) L/D Apparatus Assembly (continued)

## 6. Procedure

- 6.1 Place the NU device against the cassette with the finely spaced rods nearest the cassette.
- 6.1 Align the plane of the cassette-imaging device perpendicular to the axis of the neutron beam.
- 6.2 Insert spacers of known thickness, if required.
- 6.3 Place the NU device against the imaging device (or spacers) with the finely spaced rods nearest the imaging device if using an A unit.
- 6.4 Expose the single-emulsion film and NU device for a time span that will produce a nominal background film density of  $2.5 \pm 0.4$ .
- Film Procedure:
- 6.4.1 Expose the single-emulsion film and NU device for a time span that will produce a nominal background film density of  $2.5 \pm 0.4$ .
- 6.4.2 Process the exposed film in accordance with the manufacturer's recommendations.
- 6.4.3 Analyze the resultant image in accordance with one or more of the three methods outlined in Section 7.
- 6.4.4 Digitization of film (optional) should be performed with a transmission scanner. A minimum of 300 dpi for scanning is required. Accuracy is improved considerably at or above 600 dpi.
- 6.5 Process the exposed film in accordance with the manufacturer's recommendations.
- CR Procedure:
- 6.5.1 CR images must be produced using an image plate with either an embedded conversion material (i.e. gadolinium), or a high resolution image plate pressed against a suitable conversion screen. High resolution and low noise are both required for accurate determination of the L/D ratio.

- 6.5.2 Expose the CR screen for a sufficient duration to optimize image production.
  - 6.5.3 Scan the imaging phosphor with 100 um or smaller pixel pitch.
  - 6.5.4 Produce the image without any edge enhancement, or other image enhancements.
  - 6.5.5 Analyze the resulting image in accordance with the visual or line plot analysis method.
- 6.5 Analyze the resultant image in accordance with one or more of the three methods outlined in Section 7.

## 7. Data Analysis

The alternative line plot analysis method described in section 7.3 has the best repeatability, but is not suitable for use with current CR systems. A CR system with 15 um or smaller pixel pitch might be able to use the method detailed in 7.3. When generating line plots, averaging through the use of a multiple pixel wide line substantially improves repeatability of the results.

7.1 *Visual Analysis*—A visual determination of the *L/D* ratio can be made directly from the neutron radiograph—radiographic image. When observing the individual rod images, the umbral image can be recognized as the “white” line along the center of the rod image. This “white” line will decrease in width for the rods located farther and farther from the film. At some point the umbral images will disappear. Beyond this point a less intense white line will appear and increase in width with increasing rod distance. Use of a 5 to 10-power magnifier for film, or digital magnification for digital images will aid in determining the point at which the “white” line disappears and then increases in width with a decreased intensity. Based on the visual observation, determine the rod with zero umbral width and then determine its distance (*b*) from the cassette. The *L/D* ratio is calculated as follows:

$$L/D = (b/\text{rod diameter})$$

7.2 *Microdensitometric—Line Plot Analysis*—The second data analysis method is based on a microdensitometric—scan microdensitometric, line plot from a digitized film, or a line plot from a digital CR image. The line plot is taken across the cadmium rod images beginning with the “0” position rod nearest the film. A typical scan—line plot is shown in Fig. 4. A densitometer aperture of 20 × 300 μm and no horizontal expansion is suggested for this method. The value of *b* is obtained from the intersection of a straight line originating from the tip (low film density) of the scan of the “0” rod and a curved line through the tips of the remaining wave forms as shown in Fig. 4. This method gives the best results suitable for use for *L/D* ratios up to a few hundred. Higher *L/D* ratios cannot be determined accurately by this method due to the inability to obtain a stable wave form for large values of *b*. If spacers or an offset distance are present between the E803 device and the imaging device, this method cannot be used.

7.3 *Alternative Microdensitometric—Line Plot Analysis*—This method also uses a line plot or scanning microdensitometric traces for *L/D* ratio determinations and is applicable for both high and low *L/D* ratios. For this method the recommended microdensitometer settings are: 20 × 300 μm aperture and 50× (or more) chart recording expansion. These settings will produce individual wave forms as shown—Line plots similar to those in Fig. 5. At least two wave forms must be scanned, one near the film plane and one other near the point where the umbra disappears. Care must be taken not to go beyond the point where the umbral image disappears. Microdensitometer settings must remain the same for all scans. For are produced, for each wire *L/D* ratios above 100, the “0” centimetre rod image should not be used because the unsharpness due to the film/conversion screen combination overrides the unsharpness due to the to *L/D* ratio. For the lower *L/D* ratios (under ~100), the simplified equation using  $X_2$  and  $U_0$  for the “0” rod image may be used with good results: be analyzed.

7.3.1 To determine the value of *b* it is necessary to measure the umbral image width for the two rods selected. This dimension—umbral width is measured along a horizontal line (parallel to background) through the average of the low-density scan of the individual wave form—form (i.e. the segment corresponding with the umbral shadow). The desired dimension is the distance between the intersections of this horizontal line with lines drawn through the two sides of the wave form. The measurement may be centimetres or inches and need not be converted to the unmagnified value: unit of measurement and scan/magnification settings must be consistent through measurement of all individual wave forms.

7.3.2 Using this dimension, determine the value of *b* as follows (see Fig. 6):

$$b = (U_1 X_1) / (U_1 - U_2) + X_0$$

where:

- $U_1$  = umbral width of a rod near the image plane;
- $U_2$  = umbral image width of a rod near the distance where the umbra disappears;
- $X_0$  = distance from the film to the rod chosen for  $U_1$ , cm, and
- $X_1$  = distance between the two rods chosen for analysis, cm.

Since—At least two wave forms must be plotted, one near the film plane and one near the point where the umbra disappears. Increasing the number of wave forms plotted improves accuracy. Care must be taken not to go beyond the point where the umbral image disappears. If the *L/D* = devices  $b/\text{rod diameter}$ , it is possible to determine—are placed directly against the imaging device, the five cadmium wires closest to the imaging device should not be used because the unsharpness due to the imaging device/conversion screen combination overrides the unsharpness due to the *L/D* directly as follows: ratio.

$$L/D = \left[ \frac{U_1 X_1}{U_1 - U_2} + X_0 \right] / \text{rod diameter}$$