



Designation: D4962 – 17

Standard Practice for NaI(Tl) Gamma-Ray Spectrometry of Water¹

This standard is issued under the fixed designation D4962; the number immediately following the designation indicates the year of original adoption or, in the case of revision, the year of last revision. A number in parentheses indicates the year of last reapproval. A superscript epsilon (ϵ) indicates an editorial change since the last revision or reapproval.

1. Scope

1.1 This practice covers the measurement of radionuclides in water by means of gamma-ray spectrometry. It is applicable to nuclides emitting gamma-rays with energies greater than 50 keV. For typical counting systems and sample types, activity levels of about 40 Bq (1080 pCi) are easily measured and sensitivities of about 0.4 Bq (11 pCi) are found for many nuclides **(1-10)**.² Count rates in excess of 2000 counts per second should be avoided because of electronic limitations. High count rate samples can be accommodated by dilution or by increasing the sample to detector distance.

1.2 This practice can be used for either quantitative or relative determinations. In tracer work, the results may be expressed by comparison with an initial concentration of a given nuclide which is taken as 100 %. For radioassay, the results may be expressed in terms of known nuclidic standards for the radionuclides known to be present. In addition to the quantitative measurement of gamma-ray activity, gamma-ray spectrometry can be used for the identification of specific gamma-ray emitters in a mixture of radionuclides. General information on radioactivity and the measurement of radiation has been published **(11 and 12)**. Information on specific application of gamma-ray spectrometry is also available in the literature **(13-16)**.

1.3 The values stated in SI units are to be regarded as standard. The values given in parentheses after SI units are included for information only and are not considered standard.

1.4 *This standard does not purport to address all of the safety concerns, if any, associated with its use. It is the responsibility of the user of this standard to establish appropriate safety, health, and environmental practices and determine the applicability of regulatory limitations prior to use.*

1.5 *This international standard was developed in accordance with internationally recognized principles on standardization established in the Decision on Principles for the*

Development of International Standards, Guides and Recommendations issued by the World Trade Organization Technical Barriers to Trade (TBT) Committee.

2. Referenced Documents

- 2.1 *ASTM Standards*:³
[D1129 Terminology Relating to Water](#)
[D3648 Practices for the Measurement of Radioactivity](#)
[D7902 Terminology for Radiochemical Analyses](#)
[E181 Test Methods for Detector Calibration and Analysis of Radionuclides](#)

3. Terminology

3.1 Definitions:

3.1.1 For definitions of terms used in this standard, refer to Terminologies [D1129](#) and [D7902](#).

4. Summary of Practice

4.1 Gamma-ray spectra are commonly measured with modular equipment consisting of a detector, amplifier, multi-channel analyzer device, and a computer **(17 and 18)**.

4.2 Thallium-activated sodium-iodide crystals, NaI(Tl), which can be operated at ambient temperatures, are often used as gamma-ray detectors in spectrometer systems. However, their energy resolution limits their use to the analysis of single nuclides or simple mixtures of a few nuclides. A resolution of about 7 % (45 keV full width at one half the ¹³⁷Cs peak height) at 662 keV can be expected for a NaI(Tl) detector in a 76 mm by 76 mm-configuration. There are solid scintillators such as cerium doped LaBr₃ that may provide a performance advantage over NaI(Tl) in terms of energy resolution but whose suitability should be evaluated and documented before being considered as a substitute for NaI(Tl).

4.3 Interaction of a gamma-ray with the atoms in a NaI(Tl) detector results in light photons that can be detected by a photomultiplier tube (PMT). The output from the PMT and its preamplifier is directly proportional to the energy deposited by the incident gamma-ray. These current pulses are fed into an

¹ This practice is under the jurisdiction of ASTM Committee [D19](#) on Water and is the direct responsibility of Subcommittee [D19.04](#) on Methods of Radiochemical Analysis.

Current edition approved Nov. 1, 2017. Published November 2017. Originally approved in 1989. Last previous edition approved in 2009 as D4962 – 02 (2009). DOI: 10.1520/D4962-17.

² The boldface numbers in parentheses refer to the references at the end of this practice.

³ For referenced ASTM standards, visit the ASTM website, www.astm.org, or contact ASTM Customer Service at service@astm.org. For *Annual Book of ASTM Standards* volume information, refer to the standard's Document Summary page on the ASTM website.

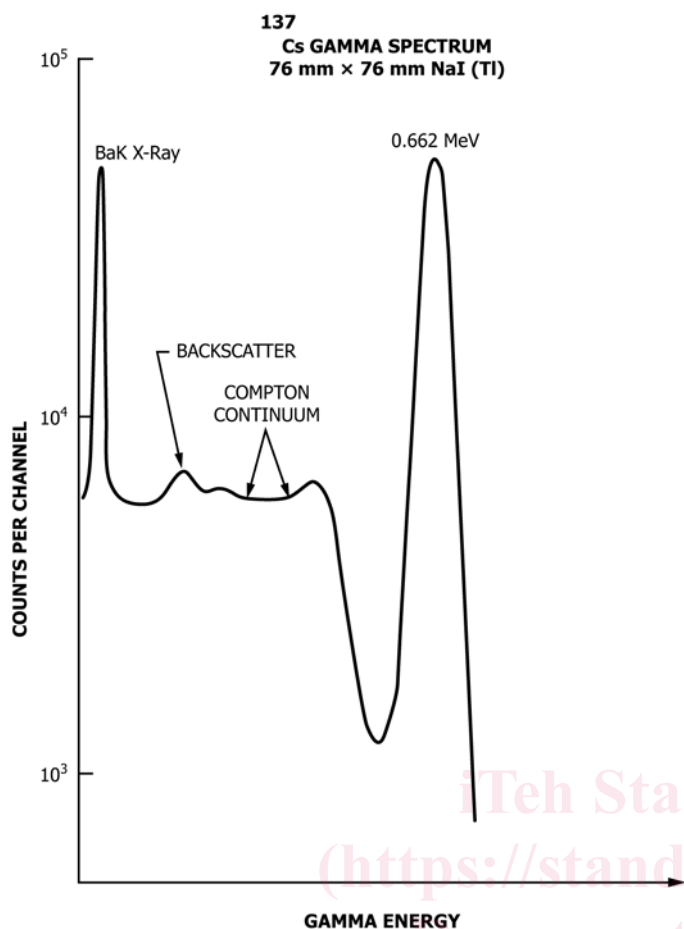

FIG. 1 Compton Continuum

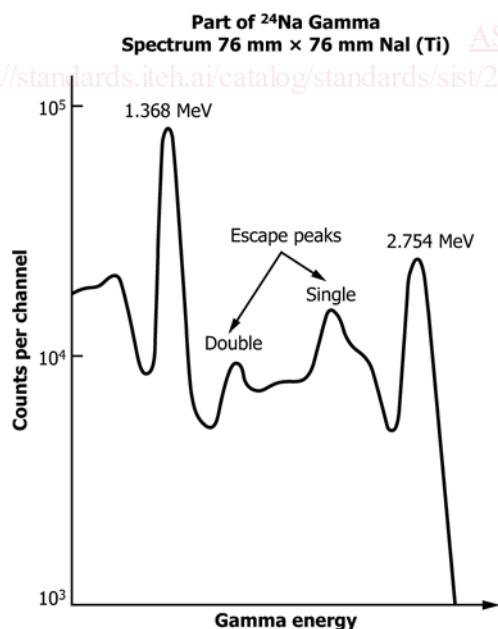

FIG. 2 Single and Double Escape Peaks

4.4 A multichannel pulse-height analyzer is used to determine the amplitude of each pulse originating in the detector, and accumulates in a memory the number of pulses in each amplitude band (or channel) in a given counting time (17 and 18). For a 0 to 2 MeV spectrum two hundred channels may be adequate but most current systems provide a thousand or more channels.

4.5 The distribution of the amplitudes (pulse heights) of the pulse energies, represented by the pulse height, can be separated into two principal components. One of these components has a nearly Gaussian distribution and is the result of total absorption of the gamma-ray energy in the detector; this peak is normally referred to as the full-energy peak or photopeak. The other component is a continuous one, lower in energy than the photopeak. This continuous curve is referred to as the Compton continuum and results from interactions wherein the gamma photons lose only part of their energy to the detector.

4.6 Other peaks components, such as escape peaks, backscattered gamma-rays, or X-rays from shields, are often superimposed on the Compton continuum. These portions of the curve are shown in Fig. 1 and Fig. 2.

4.7 Escape peaks will be present when gamma-rays with energies greater than 1.02 MeV are emitted from the sample (19-24). The positron formed in pair production is usually annihilated in the detector and one or both of the 511 keV annihilation quanta may escape from the detector without interaction. This condition will cause single- or double-escape peaks at energies of 0.511 or 1.022 MeV less than the photopeak energy.”

4.8 In the plot of pulse height versus count rate, the size and location of the photopeak on the pulse height axis is proportional to the number and energy of the incident photons, and is the basis for the quantitative and qualitative application of the spectrometer. The Compton continuum serves no useful quantitative purpose in photopeak analysis and must be subtracted from the photopeak to obtain the correct number of counts before peaks are analyzed.

4.9 If the analysis is being directed and monitored by an online computer program, the analysis period may be terminated by prerequisites incorporated in the program. Analysis may also be terminated when a preselected time or total counts in a region of interest or in a specified channel is reached. Visual inspection of the computer monitor can also be used as a criterion for manually terminating the analysis.

4.10 Upon completion of the analysis, the spectral data are interpreted and reduced to nuclide activity of becquerels (disintegrations per second) or related units suited to the particular application. At this time, the spectral data may be inspected on the monitor to identify the gamma-ray emitters present. This is accomplished by reading the channel number from the x-axis and converting to gamma-ray energy by means of an equation relating channel number and gamma-ray energy. If the system is calibrated for 2 keV per channel with channel zero representing 0 keV, the energy can be readily calculated. In some systems the channel number or gamma-ray energy in keV can be displayed on the monitor for any selected channel.

amplifier of sufficient gain to produce voltage output pulses in the amplitude range from 0 to 10 V.

Identification of nuclides may be aided by libraries of gamma-ray spectra and other nuclear data tabulations (25-30).

4.11 Data reduction of spectra involving mixtures of nuclides is usually accomplished using a library of standard spectra of the individual nuclides acquired under conditions identical to that of the unknown sample (25-30).

5. Significance and Use

5.1 Gamma-ray spectrometry is used to identify radionuclides and to make quantitative measurements. Use of a computer and a library of standard spectra will be required for quantitative analysis of complex mixtures of nuclides.

5.2 Variation of the physical geometry of the sample and its relationship with the detector will produce both qualitative and quantitative variations in the gamma-ray spectrum. To adequately account for these geometry effects, calibrations are designed to duplicate all conditions including source-to-detector distance, sample shape and size, and sample matrix encountered when samples are measured. This means that a complete set of library standards may be required for each geometry and sample to detector distance combination that will be used.

5.3 Since some spectrometry systems are calibrated at many discrete distances from the detector, a wide range of activity levels can be measured on the same detector. For high-level samples, extremely low efficiency geometries may be used. Quantitative measurements can be made accurately and precisely when high activity level samples are placed at distances of 1 m or more from the detector.

5.4 Electronic problems, such as erroneous deadtime correction, loss of resolution, and random summing, may be avoided by keeping the gross count rate below 2 000 counts per second and also keeping the deadtime of the analyzer below 5 %. Total counting time is governed by the activity of the sample, the detector source distance, and the acceptable Poisson counting uncertainty.

6. Interferences

6.1 In complex mixtures of gamma-ray emitters, the degree of interference of one nuclide in the determination of another is governed by several factors. If the gamma-ray emission rates from different radionuclides are similar, interference will occur when the photopeaks are not completely resolved and overlap. A method of predicting the gamma-ray resolution of a detector is given in the literature (31). If the nuclides are present in the mixture in unequal portions radiometrically, and nuclides of higher gamma-ray energies are predominant, there are serious interferences with the interpretation of minor, less energetic gamma-ray photopeaks. The complexity of the analysis method is due to the resolution of these interferences and, thus, one of the main reasons for computerized systems.

6.2 Cascade summing may occur when nuclides that decay by a gamma-ray cascade are analyzed. Cobalt-60 is an example; 1773 and 1333 keV gamma-rays from the same decay may enter the detector to produce a sum peak at 2506 keV and cause the loss of counts from the other two peaks. Cascade

summing may be reduced by increasing the source to detector distance. Summing is more significant if a well-type detector is used.

6.3 Random summing occurs in all measurements but is a function of count rate. The total random summing rate is proportional to the square of the total number of counts. For most systems, random summing losses can be held to less than 1 % by limiting the total counting rate to 2000 counts per second (see Test Methods E181).

6.4 The density of the sample is another factor that can affect quantitative results. This source of error can be avoided by preparing the standards for calibration in matrices of the same density of the sample under analysis.

7. Apparatus

7.1 *Gamma Ray Spectrometer*, consisting of the following components, as shown in Fig. 3. Some currently available commercial systems incorporate the power supply, preamplifier, amplifier, and multichannel analyzer into a single unit.

7.1.1 *Detector Assembly*—Sodium iodide crystal, activated with about 0.1 % thallium iodide, cylindrical, with or without an inner sample well, 51 to 102 mm in diameter, 44 to 102-mm high, and hermetically sealed in an opaque container with a transparent window. The crystal should contain less than 5 µg/g of potassium, and should be free of other radioactive materials. In order to establish freedom from other radioactive materials, the manufacturer should supply the gamma-ray spectrum of the background of the crystal between 80 and 3000 keV. The

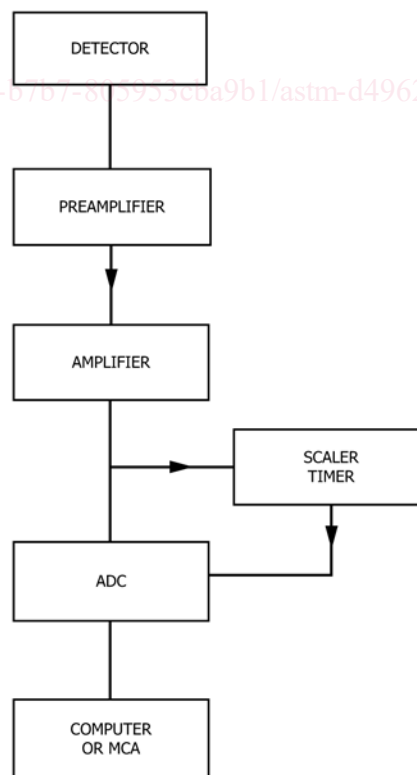

FIG. 3 Gamma Spectrometry System

crystal should be attached and optically coupled to a photomultiplier or other suitable optical sensor such as an avalanche photodiode. A photomultiplier requires a preamplifier or a cathode follower compatible with the amplifier. The resolution (FWHM) of the assembly for the photopeak of ^{137}Cs should be less than 9 %.

7.1.2 Shield—The detector assembly shall be surrounded by an external radiation shield made of dense metal, equivalent to 102 mm of lead in gamma-ray attenuation capability. It is desirable that the inner walls of the shield be at least 127 mm distant from the detector surfaces to reduce backscatter. If the shield is made of lead or a lead liner, the shield may have a graded inner liner of 1.6 mm of cadmium or tin lined with 0.4 mm of copper, to attenuate lead X-rays at 88 keV, on the surface near the detector. The shield must have a door or port for inserting and removing samples.

7.1.3 High Voltage Power/Bias Supply—High-voltage power supply of range (usually from 500 to 3000 V and up to 10 mA) sufficient to operate a NaI(Tl) detector, photomultiplier, and its preamplifier assembly. The power supply shall be regulated to 0.1 % with a ripple of not more than 0.01 %. Line noise caused by other equipment shall be removed with radiofrequency filters and additional regulators.

7.1.4 Preamplifier/Amplifier—An amplifier compatible with the preamplifier or emitter follower and with the pulse-height analyzer.

7.1.5 Scalar/Timer—A scalar/timer may be used to monitor the count and regulate the spectral acquisition.

7.1.6 ADC/MCA—A multichannel pulse-height analyzer (MCA) or stand-alone analog-to-digital-converter (ADC) under software control of a separate computer, performs many functions required for gamma-ray spectrometry. An MCA or computer collects the data, provides a visual display, and outputs final results or raw data for later analysis. The four major components of an MCA are the ADC, the memory, the control, and the input/output circuitry and devices. The ADC digitizes the analog pulses from the detector amplifier. These pulses represent energy. The digital result selects a memory location (channel number) which is used to store the number of events which have occurred with that energy. Simple data analysis and control of the MCA is accomplished by controlling factors such as the input/output, channel summing over set regions of interest, and system energy calibration.

7.1.7 Data Storage—Because of the use of microprocessors, modern MCAs provide a wide range of input and output (I/O) capabilities to an associated computer.

8. Container for Test Specimen

8.1 Sample mounts and containers must have a convenient reproducible geometry. Considerations include commercial availability, ease of use and disposal, and the containment of radioactivity for protection of the working environment and personnel from contamination. The evaporation of liquid samples to dryness is not necessary and liquid samples up to several litres may be used. However, samples that have been evaporated to dryness for gross beta counting can also be used for gamma-ray spectrometry. Massive samples may cause significant self-absorption of low-energy gamma-rays and

degrade the higher-energy gamma-rays. Therefore, it is important to calibrate the detector with standards of the same geometry and density. A beta absorber consisting of about 6 mm of aluminum, beryllium, or plastic may be used for samples that have a significant beta activity and high beta energies.

9. Single or Simple Mixtures of Radionuclides

9.1 Calibration and Standardization:

9.1.1 Begin operation of the instrumentation and detector according to the manufacturer's instructions. Initial set-up includes all electronic adjustment to provide constant operating conditions consistent with the application and life expectancy of the calibrations. Adjust the analog-to-digital converter gain and threshold, amplifier gain and zero-level, and detector high voltage, or bias, to yield an optimum energy calibration, usually 2 keV per channel. Modern commercial equipment is capable of linearity to the extent that the energy may be interpreted by the operator directly to the nearest 5 keV simply by reading the channel number of the highest channel in a peak. The energy calibration is usually accomplished with radioactive sources covering the entire range of interest. All efficiency calibrations and source analyses are performed with the same gain settings and the same high voltage setting. Obtain efficiency calibrations by placing an appropriate volume of a radionuclide standard solution traceable to a national metrology institute such as NIST⁴ containing 100 to 10 000 Bq in a container and placing the container on the detector or in the detector well.

9.1.2 Preparation of Apparatus:

9.1.2.1 Follow the manufacturer's instructions, limitations, and cautions for the set up of and the preliminary testing for all of the spectrometry equipment to be used in the analysis. This equipment could include detectors, power supplies, preamplifiers, amplifiers, multichannel analyzers, and computers. Some currently available commercial systems incorporate the power supply, preamplifier, amplifier, and multichannel analyzer into a single unit.

9.1.2.2 Place an appropriate volume of a single radionuclide or mixed radionuclide standard traceable to a national metrology institute such as NIST in a sealed container and place the container at a desirable and reproducible source-to-detector distance. The solution above should provide about 100 counts per second in the peaks of interest. In all radionuclide measurements, the volumes, shape, and physical and chemical characteristics of the samples, and the corresponding standard, and their containers must be as identical as practicable for the most accurate results. If precipitates or residues are to be analyzed, then evaporate the standards on the same type of mount as the sample.

9.1.3 Energy Calibration:

9.1.3.1 Multichannel analyzers and NaI(Tl) detectors being produced today are capable of producing an almost linear energy response.

9.1.3.2 The energy calibration (channel number of the multichannel analyzer versus the gamma-ray energy) of the

⁴ Available from National Institute of Standards and Technology (NIST), 100 Bureau Dr., Stop 1070, Gaithersburg, MD 20899-1070, <http://www.nist.gov>.