



Designation: **D7247 – 16 D7247 – 17**

# Standard Test Method for Evaluating the Shear Strength of Adhesive Bonds in Laminated Wood Products at Elevated Temperatures<sup>1</sup>

This standard is issued under the fixed designation D7247; the number immediately following the designation indicates the year of original adoption or, in the case of revision, the year of last revision. A number in parentheses indicates the year of last reapproval. A superscript epsilon ( $\epsilon$ ) indicates an editorial change since the last revision or reapproval.

## 1. Scope

1.1 This standard describes a test method for evaluating the comparative shear strength of a planar adhesive bond at both ambient and elevated temperatures relative to the performance of solid wood under the same conditions. The test method is based on the breaking load after the specimen is exposed to either ambient or a constant elevated temperature for a specified duration as described in Section 7. This standard does not preclude the development and implementation of other methods that provide equivalent performance meeting the intent of this method.

1.2 This test method is intended for the evaluation of adhesives that can be used to assemble test specimens in accordance with Test Method D905. The evaluation of other types of adhesives, such as the binder systems used for strand-based products, is beyond the scope of this test method, except as noted in 1.4.

1.3 This test method is intended for the evaluation of adhesives as a component of laminated wood products at elevated temperatures. The evaluation of fire performance on fire-rated laminated wood products or assemblies is beyond the scope of this test method.

1.4 This test method may be used for the evaluation of heat durability for binder adhesives used in strand-based structural wood composites, such as oriented strand lumber (OSL) and laminated strand lumber (LSL), by substituting strand-based composite specimens for the bonded specimens.

1.5 The exact formulation of adhesive supplied to the manufacturer of laminated wood products shall be evaluated. Modifications to the adhesive formulation require a separate evaluation unless approved by the manufacturer of the laminated wood product, qualified agency, and code evaluation agency.

1.6 The values stated in SI units are to be regarded as the standard. The values given in parentheses are for information only.

1.7 *This standard does not purport to address all of the safety concerns, such as the fire hazard, if any, associated with its use. It is the responsibility of the user of this standard to establish appropriate safety, health, and environmental practices and determine the applicability of regulatory limitations prior to use.*

1.8 *This international standard was developed in accordance with internationally recognized principles on standardization established in the Decision on Principles for the Development of International Standards, Guides and Recommendations issued by the World Trade Organization Technical Barriers to Trade (TBT) Committee.*

## 2. Referenced Documents

### 2.1 ASTM Standards:<sup>2</sup>

D905 Test Method for Strength Properties of Adhesive Bonds in Shear by Compression Loading

D907 Terminology of Adhesives

D2395 Test Methods for Density and Specific Gravity (Relative Density) of Wood and Wood-Based Materials

D2915 Practice for Sampling and Data-Analysis for Structural Wood and Wood-Based Products

D4933 Guide for Moisture Conditioning of Wood and Wood-Based Materials

D5266 Practice for Estimating the Percentage of Wood Failure in Adhesive Bonded Joints

D5456 Specification for Evaluation of Structural Composite Lumber Products

<sup>1</sup> This test method is under the jurisdiction of ASTM Committee D14 on Adhesives and is the direct responsibility of Subcommittee D14.30 on Wood Adhesives. Current edition approved April 1, 2016. Published October 15, 2017. Originally approved in 2006. Last previous edition approved in 2007 as D7247 – 07a<sup>1</sup>, which was withdrawn January 2016 and reinstated in April 2016 as D7247 – 16. DOI: 10.1520/D7247-16.10.1520/D7247-17.

<sup>2</sup> For referenced ASTM standards, visit the ASTM website, www.astm.org, or contact ASTM Customer Service at service@astm.org. For Annual Book of ASTM Standards volume information, refer to the standard's Document Summary page on the ASTM website.

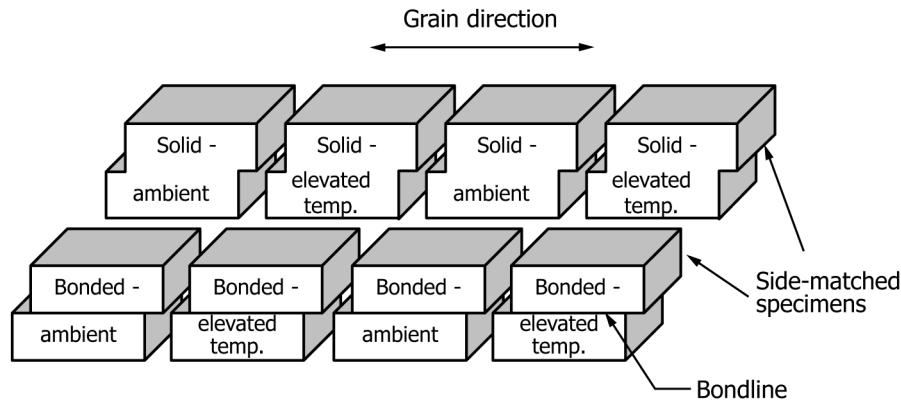

Note—See Fig. 2 for specimen dimension.

**FIG. 1 Example of Side-Matched Specimen Fabrication (Using Nominal 2 by 6 in. Lumber with Bonded Specimens and Side-Matched Solid Wood Control Specimens)**

## 2.2 Other Documents:

[ANSI A190.1 American National Standard for Wood Products — Structural Glued Laminated Timber](#)<sup>3</sup>

[ANSI/AWC NDS-2015 National Design — Specification for Wood Construction \(NDS\)](#)<sup>3</sup>

[Wood Handbook Wood as an Engineering Material](#)<sup>4</sup>

## 3. Terminology

### 3.1 Definitions:

3.1.1 Many terms in this test method are defined in Terminology [D907](#).

## 4. Significance and Use

4.1 A discussion of the issues and limitations associated with the measurement of strength properties of adhesive bonds in shear by compression loading is found in Test Method [D905](#).

4.2 While various combinations of test temperature and heat exposure duration can be used, the provisions specified in [7.2.4](#) shall be based on the understanding that the objective of this test method is to evaluate adhesive bond performance just before wood begins to burn and the elevated temperature is selected to be slightly below the unpiloted ignition temperature for wood when taken into account the specific product and its end-use applications.

4.3 When using this test method, consideration shall be given to the unique production conditions, such as wood moisture content, applied spread rate, press pressure, and curing temperature of the adhesive.

## 5. Apparatus

5.1 The testing machine and shearing tool described in Test Method [D905](#) have been found to be satisfactory for the test method described herein.

5.2 An oven capable of maintaining the targeted test temperature to within  $\pm 1\%$  and with sufficient air circulation to provide constant temperature conditions within the oven interior is required for heating the specimens.

5.3 Thermometers/thermocouples capable of measuring the temperature of the test specimen and air are required.

NOTE 1—Type “K” 24 gauge thermocouples are recommended.

5.4 *Dessicator*, capable of maintaining the dry condition of the dried specimen sets until exposure and testing.

NOTE 2—Fresh or freshly regenerated desiccant is recommended for each test.

## 6. Test Specimen

6.1 The wood species used for the tests shall be the wood species used in commercial production. Wood species with similar bonding characteristics in accordance with ANSI A190.1 shall be permitted to be grouped for the purpose of this test method. Nominal 2-in. thick lumber shall be used to manufacture the test specimens. The lumber shall have the annual growth rings oriented 45 to 90°, as measured from the wide face (vertical grain), and be free of defects and at the equilibrium moisture content recommended by the manufacturer of the adhesive. If no such recommendation exists, the moisture content shall be between 10 and 12 % prior to bonding following the moisture conditioning procedures described in Guide [D4933](#). Each piece of lumber used

<sup>3</sup> APA — The Engineered Wood Association, 7011 S. 19th St., Tacoma, WA 98466, [www.apaword.org](http://www.apaword.org).

<sup>4</sup> Available from U.S. Department of Agriculture, Forest Service, Forest Products Laboratory, One Gifford Pinchot Drive Madison, WI 53726, [www.fpl.fs.fed.us](http://www.fpl.fs.fed.us).

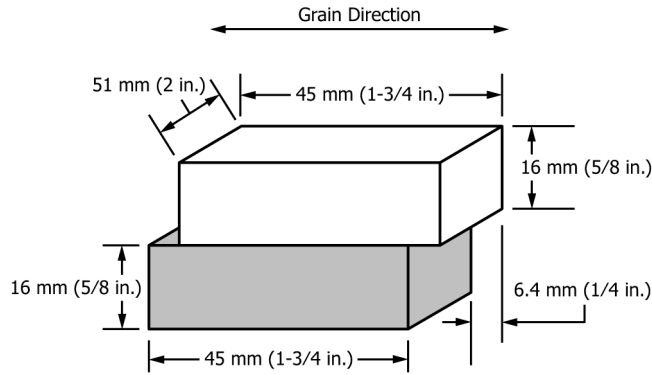

FIG. 2 Form and Dimensions of a Bonded Specimen

as part of this test method shall have a specific gravity equal to or exceeding the value specified in the National Design Specification for Wood Construction (NDS) for the wood species, as determined in accordance with Test Methods D2395 based on oven-dry weight and volume. The specific gravity determination for each piece of lumber shall be permitted to be conducted on the ends trimmed from the lumber during the preparation of the bonded and solid wood test specimens. The side-matched components stock from which the bonded and solid wood control specimens are prepared shall have a specific gravity within  $\pm 0.02$  of each other (for example, if the solid wood control specimens have a specific gravity of 0.50, the bonded specimens shall have a specific gravity between 0.48 and 0.52);  $\pm 0.02$  of each other.

6.2 Specimens shall be prepared in accordance with the general principle of Test Method D905. To ensure that pieces with a mean specific gravity are bonded together, a single piece of the nominal 2 in. thick lumber shall provide, at a minimum, the two pieces (lumber) necessary for each bonded specimen and a side-matched solid wood (control) specimen. An example of the shear specimen-cutting pattern is shown in Fig. 1. Care shall be exercised to ensure the same annual ring orientation when bonding the lumber together into a bonded assembly.

6.3 The mating surfaces of the lumber used to prepare the bonded specimens shall be surfaced no more than 24 h prior to bonding. The adhesive preparation, spread rate, clamping pressure and clamping time shall follow the adhesive manufacturer's recommendations. The production conditions for the end-use products shall also be considered (see 4.3).

6.4 A minimum of 20 bonded specimens shall be prepared in accordance with Fig. 2. The bonded specimens will have a thickness less than the specified 38 mm (1.5 in.) as described in Test Method D905 due to surfacing from nominal 2-in lumber. In addition, a minimum of 20 solid wood (without the bondline) control specimens side-matched with the bonded specimens shall be prepared as shown in Fig. 1. The side-matched solid wood specimens shall be surfaced to the same thickness as the bonded specimens. The bonded and matched solid wood control specimens shall be prepared as 20 pairs.

6.5 A total of 10 pairs of bonded and matched solid wood control specimens shall be tested at ambient temperature and the remaining 10 pairs of bonded and matched solid wood control specimens shall be tested at the targeted elevated temperature.

6.6 For specimens tested at the elevated temperature, a hole shall be drilled through one lamination at a 90° angle to the bondline and extending 0.6 mm ( $\frac{1}{32}$  in.) past the bondline. The drilled hole shall allow the thermocouple wire casing to fit snugly inside the hole (see Fig. 3), with the exposed portion of the thermocouple wire touching the bondline of the bonded specimen or the geometric center (shear plane) of the matched solid wood control specimen. The tip of the thermocouple wire shall have a maximum of 1 mm (0.040 in.) of insulation removed.

NOTE 3—Experience has shown that stripping the wire insulation approximately 12.7 mm (0.5 in.), twisting the wires together, and cutting the exposed wire back to 1 mm (0.040 in.) gives consistent results. Damage to or improper removal of thermocouple wire insulation increases the possibility of inaccurate temperature readings in the oven. Prior to re-using thermocouple wire, it is to be re-tested to ensure that accurate temperature readings are being provided.

6.7 All specimens shall be oven dried for 48 h at  $60 \pm 2^\circ\text{C}$  ( $140 \pm 4^\circ\text{F}$ ) and placed in an atmosphere, such as a desiccator, to allow for cooling in dry conditions.

NOTE 4—The intent of the oven drying is to remove the moisture from the wood adherend so that the specimen weight reduction during testing in accordance with Section 7 is primarily due to thermal degradation.

6.8 After cooling, the specimen weight shall be determined. The width and length of the test specimen shall be measured and recorded, at the bondline, to the nearest 0.25 mm (0.010 in.) to determine the shear area. Test specimens are to be kept in the desiccator until just prior to testing in accordance with Section 7.

## 7. Test Procedures

### 7.1 Specimens at Ambient Temperature Condition: