



Standard Test Method for Fire Testing of Stacked Chairs¹

This standard is issued under the fixed designation E1822; the number immediately following the designation indicates the year of original adoption or, in the case of revision, the year of last revision. A number in parentheses indicates the year of last reapproval. A superscript epsilon (ϵ) indicates an editorial change since the last revision or reapproval.

1. Scope*

1.1 This is a fire-test-response standard.

1.2 This test method provides a means of determining the burning behavior of stacking chairs used in public occupancies by measuring specific fire-test responses when a stack of chairs is subjected to a specified flaming ignition source under well ventilated conditions.

1.3 This test method is limited to stacked chairs.

1.4 Test data are obtained describing the burning behavior following application of a specific ignition source, from ignition until all burning has ceased, a period of 1 h has elapsed, or flashover under test conditions appears inevitable.

1.5 This test method does not provide information on the fire performance of stacked chairs under fire conditions other than those conditions specified in this test method. In particular, this test method does not apply to smoldering ignition by cigarettes. See 5.11 for further information.

1.6 The rate of heat release of the burning test specimen is measured by an oxygen consumption method. See 5.11.4 for further information.

1.7 Other measurements are the production of light-obscuring smoke and the concentrations of certain toxic gas species in the combustion gases. See 5.11.5 for further information.

1.8 The burning behavior is documented visually by photographic or video recordings.

1.9 *This standard is used to measure and describe the response of materials, products, or assemblies to heat and flame under controlled conditions, but does not by itself incorporate all factors required for fire hazard or fire risk assessment of the materials, products or assemblies under actual fire conditions.*

1.10 *Fire testing is inherently hazardous. Adequate safeguards for personnel and property shall be employed in conducting these tests.*

¹ This test method is under the jurisdiction of ASTM Committee E05 on Fire Standards and is the direct responsibility of Subcommittee E05.15 on Furnishings and Contents.

Current edition approved Nov. 1, 2017. Published December 2017. Originally approved in 1996. Last previous edition approved in 2013 as E1822 – 13. DOI: 10.1520/E1822-17.

1.11 Use the SI system of units in referee decisions; see [IEEE/ASTM SI-10](#). The units given in parentheses are for information only.

1.12 *This standard does not purport to address all of the safety concerns, if any, associated with its use. It is the responsibility of the user of this standard to establish appropriate safety, health, and environmental practices and determine the applicability of regulatory limitations prior to use.*

1.13 *This international standard was developed in accordance with internationally recognized principles on standardization established in the Decision on Principles for the Development of International Standards, Guides and Recommendations issued by the World Trade Organization Technical Barriers to Trade (TBT) Committee.*

2. Referenced Documents

2.1 *ASTM Standards:*²

D123 Terminology Relating to Textiles

E84 Test Method for Surface Burning Characteristics of Building Materials

E176 Terminology of Fire Standards

E800 Guide for Measurement of Gases Present or Generated During Fires

E1354 Test Method for Heat and Visible Smoke Release Rates for Materials and Products Using an Oxygen Consumption Calorimeter

E1474 Test Method for Determining the Heat Release Rate of Upholstered Furniture and Mattress Components or Composites Using a Bench Scale Oxygen Consumption Calorimeter

E1537 Test Method for Fire Testing of Upholstered Furniture

E1590 Test Method for Fire Testing of Mattresses

IEEE/ASTM SI-10 American National Standard for Use of the International System of Units (SI): The Modern Metric System

² For referenced ASTM standards, visit the ASTM website, www.astm.org, or contact ASTM Customer Service at service@astm.org. For *Annual Book of ASTM Standards* volume information, refer to the standard's Document Summary page on the ASTM website.

*A Summary of Changes section appears at the end of this standard

2.2 ISO Standards:

ISO 4880 Burning Behaviour of Textiles and Textile Products—Vocabulary³

ISO 9705 Fire Tests—Full Scale Room Test for Surface Products³

ISO 13943 Fire Safety—Vocabulary³

2.3 UL Standards:

UL 1056 Fire Test of Upholstered Furniture (withdrawn)⁴

UL 1895 Fire Test of Mattresses (withdrawn)⁴

2.4 CA Standards:

CA TB 129, Flammability Test Procedure for Mattresses for Use in Public Buildings⁵

CA TB 133, Flammability Test Procedure for Seating Furniture for Use in Public Occupancies⁵

2.5 NFPA Standard:

NFPA 289 Standard Method of Fire Test for Individual Fuel Packages⁶

2.6 Other Document:

Nordtest Method NT Fire 032 Upholstered Furniture: Burning Behavior—Full Scale Test⁷

3. Terminology

3.1 *Definitions*—For definitions of terms used in this test method and associated with fire issues, refer to Terminology **E176** and ISO 13943. In case of conflict, the definitions in Terminology **E176** shall prevail. For definitions of terms used in this test method and associated with textile issues refer to Terminology **D123** and ISO 4880. In case of conflict, the definitions in Terminology **D123** shall prevail.

3.2 Definitions of Terms Specific to This Standard:

3.2.1 *stacking chair, n*—chair that is intended to be stacked when not in use.

3.2.2 *test specimen, n*—stack of five identical stacking chairs.

3.2.3 *upholstered, adj*—covered with material (as fabric or padding) to provide a soft surface.

3.2.4 *upholstered seating furniture, n*—a unit of interior furnishing that (1) contains any surface that is covered, in whole or in part, with a fabric or other upholstery cover material, (2) contains upholstery material, and (3) is intended or promoted for sitting upon.

3.2.5 *upholstery cover material, n*—the outermost layer of fabric or related material used to enclose the main support system, or upholstery materials, or both, used in the furniture unit.

3.2.6 *upholstery material, n*—the padding, stuffing, or filling material used in a furniture item, which may be either loose or attached, enclosed by an upholstery cover material, or located between the upholstery cover material and support system, if present.

3.2.6.1 *Discussion*—This includes, but is not limited to, material such as foams, cotton batting, polyester fiberfill, bonded cellulose, or down.

4. Summary of Test Method

4.1 This fire-test-response test method determines a number of fire-test-response characteristics associated with a stack of five stacking chairs, ignited with a propane gas burner. Measurements to be made include the rate of heat and smoke release, total amount of heat released, rates and concentrations of carbon oxides released, and rates and amounts of mass of test specimen lost. Other optional measurements are also described.

4.2 In Test Configurations A and B, the test specimen is placed on a weighing platform located in a test room. An exhaust hood, connected to a duct, is located at the doorway of the room.

4.3 In Test Configuration C, the test specimen is placed on a weighing platform located directly under a hood.

4.4 Heat, smoke, and combustion gas release instrumentation is placed in the duct.

4.5 Additional (optional) instrumentation placed in the test room is also described.

5. Significance and Use

5.1 This test method provides a means of measuring a variety of fire-test-response characteristics resulting from burning a stack of five stacking chairs. After ignition using a propane gas burner, the test specimen is permitted to burn freely under well-ventilated conditions. The most important fire-test-response characteristic measured in this test method is the rate of heat release, which quantifies the intensity of the fire generated.

5.2 The rate of heat release is measured by the principle of oxygen consumption. **Annex A3** discusses the assumptions and limitations.

5.3 This test method also provides measures of other fire-test-response characteristics, including smoke obscuration (as the rate of smoke release, total smoke released or optical density of smoke), combustion gas release (as concentrations of combustion gases), and mass loss, that are important to making decisions on fire safety.

5.4 In the majority of fires, the most important gaseous components of smoke are the carbon oxides present in all fires. They are indicators of the toxicity of the atmosphere and of the completeness of combustion. Measurement of concentrations of carbon oxides are useful for two purposes: as part of fire hazard assessment calculations and to improve the accuracy of heat-release measurements. Other toxic combustion gases, which are specific to certain materials, are also indicators of the toxicity of the atmospheres, but are less crucial for determining

³ Available from International Organization for Standardization (ISO), 1, ch. de la Voie-Creuse, Case postale 56, CH-1211, Geneva 20, Switzerland, <http://www.iso.ch>.

⁴ Available from Underwriters Laboratories (UL) (hard copy only), 333 Pfingsten Rd., Northbrook, IL 60062-2096, <http://www.ul.com>.

⁵ Available from California Bureau of Home Furnishings and Thermal Insulation, State of California, Department of Consumer Affairs, 3485 Orange Grove Ave., North Highlands, CA 95660-5595.

⁶ Available from National Fire Protection Association (NFPA), 1 Batterymarch Park, Quincy, MA 02169-7471, <http://www.nfpa.org>.

⁷ Available from Nordtest, P.O. Box 22, SF-00341, Helsingfors, Finland.

combustion completeness and are optional measures; however fire hazard assessment often requires their measurement.

5.5 The type of ignition chosen (flaming source) is common in both accidental and intentional fires in public occupancies. This test method is thus applicable to stacked chairs in public occupancies. Such facilities include, but are not limited to, health-care facilities, old-age convalescent and board and care homes, college dormitories and residence halls, and hotels and motels.

5.6 One of the following three configurations is to be used in this test method:

5.6.1 *Test Configuration A*—A test room with the following dimensions: 3.66 by 2.44 by 2.44 m high (12 by 8 by 8 ft).

5.6.2 *Test Configuration B*—A test room with the following dimensions: 3.66 by 3.05 by 2.44 m high (12 by 10 by 8 ft).

5.6.3 *Test Configuration C*—An open calorimeter (or furniture calorimeter).

5.7 Rooms of other dimensions are acceptable where it has been shown that equivalent test results are obtained.

5.8 Measurements in the three test configurations listed in 5.6 have been shown to give similar results for heat release in the duct and mass loss up to a rate of heat release of 600 kW (1).⁸

5.9 Measurements of temperatures, gas concentrations, and smoke obscuration in the room are dependent on room size.

5.10 Studies on the flammability performance of furniture indicate that bench-scale fire tests are useful for preliminary evaluations of component materials for substitution purposes (see Appendix X3).

5.11 *Limitations:*

5.11.1 This test method is not applicable to ignition by cigarettes or by any other smoldering source.

5.11.2 The ignition source in this test method is a flaming source. Moreover, this particular ignition source has been shown to be able to provide a distinction among different kinds of stacked chairs. However, the fraction of actual flaming stacked chair fires occurring with ignitions more or less intense than that used here is not known.

5.11.3 It is not known whether the results of this test method will be equally valid when stacking chairs are burned under conditions different from those specified. In particular, it is unclear whether the use of a different ignition source, the same ignition source but having a different duration of flame exposure, or a different gas-flow rate will change the results.

5.11.4 The value of rate of heat release corresponding to the critical limit between propagating fires and nonpropagating fires is not known.

5.11.5 As yet, there is not a known direct correlation between smoke obscuration or smoke toxicity measurements in the exhaust duct and overall fire hazard.

6. Apparatus

6.1 *Room Layout and Instrumentation:*

⁸ The boldface numbers in parentheses refer to the list of references at the end of this test method.

6.1.1 *Test Room Layout (Test Configuration A)*—The test room shall have dimensions of 2.44 m ± 25 mm by 3.66 m ± 25 mm by 2.44 m ± 25 mm high (8 by 12 by 8 ft). The room shall have no openings other than a doorway opening 0.76 m ± 6.4 mm by 2.03 m ± 6.4 mm (30 by 80 in.), located as indicated in Fig. 1, and other small openings, as necessary to make test measurements. Construct the test room of wooden or metal studs and line it with fire-rated gypsum wallboard or calcium silicate wallboard. Position a hood, as described in Annex A1, outside the room doorway, such that it collects all of the combustion gases. There shall be no obstructions to the air supply to the test setup.

NOTE 1—Both Type X gypsum wallboard and calcium silicate wallboard with a nominal thickness of at least 13 mm (0.5 in.) have been found acceptable. If the thickness of the wallboard used is greater, it will not affect the results of this test method.

6.1.2 *Test Room Layout (Test Configuration B)*—The test room shall have dimensions of 3.05 m ± 25 mm by 3.66 m ± 25 mm by 2.44 m ± 25 mm high (10 by 12 by 8 ft). The room shall have no openings other than a doorway opening 0.97 m ± 6.4 mm by 2.06 m ± 6.4 mm (38 by 81 in.), located as indicated in Fig. 2, and other small openings, as necessary to make test measurements. Construct the test room of wooden or metal studs, and line it with fire-rated gypsum wallboard or calcium silicate wallboard. Position a hood, as described in

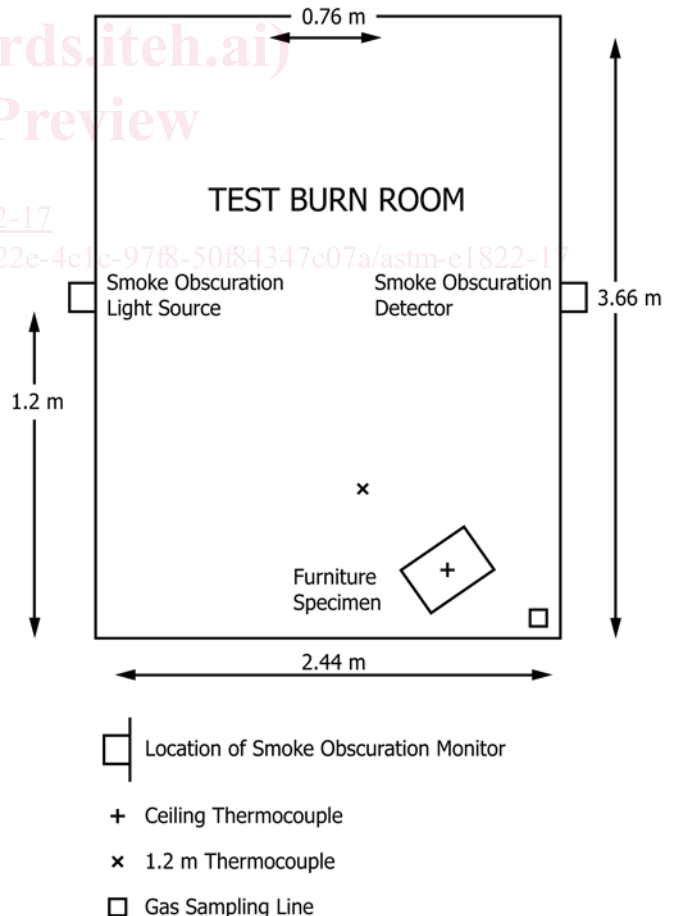

NOTE 1—See text for tolerances; room instrumentation is optional.
FIG. 1 Test Room Configuration for Test Configuration A

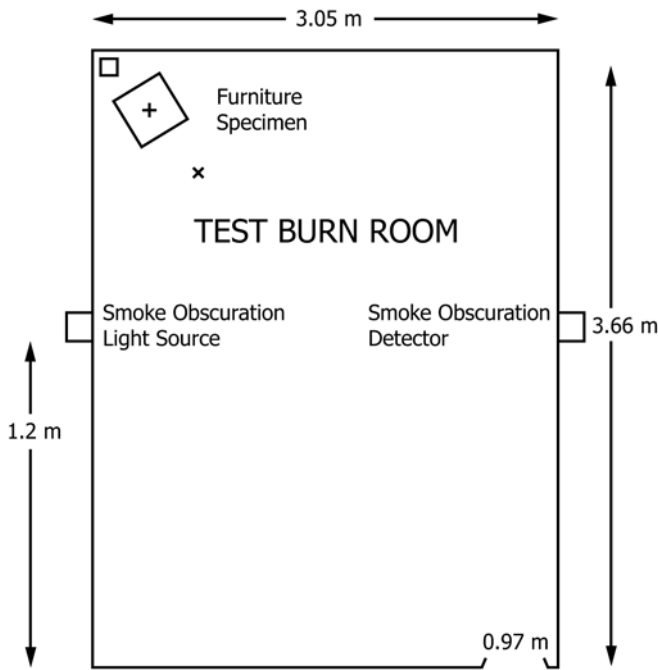

- Location of Smoke Obscuration Monitor
- Ceiling Thermocouple
- 1.2 m Thermocouple
- Gas Sampling Line

NOTE 1—See text for tolerances; room instrumentation is optional.

FIG. 2 Test Room Configuration for Test Configuration B

6.1.5 *Other Test Room Furnishings*—The test room shall contain no furnishings except for the test specimen.

6.1.6 *Location of Test Specimen, for Test Configurations A or B*—Position the test specimen on a weighing platform in a corner. Ensure that the test specimen is at a distance of between 0.10 and 0.25 m (4 and 10 in.) from both walls (Fig. 1 and Fig. 2).

6.1.7 *Location of Test Specimen, for Test Configuration C*—Position the test specimen on a weighing platform underneath the hood.

6.2 *Ignition Source:*

6.2.1 Use as the ignition source a gas burner in the shape of a T, as shown in Fig. 3.

6.2.2 Construct the burner of stainless steel with wall thicknesses of 0.89 ± 0.05 mm (0.035 ± 0.002 in.). Make the head of the T 205 ± 10 mm (8 ± 0.4 in.) long and 13 ± 1 mm (0.5 ± 0.04 in.) outside diameter. Plug the ends of the T. As shown in Fig. 3(a) and Fig. 3(b), construct the burner with two sets of holes equally spaced and centered along the head of the burner and oriented 90° to one another. One set consists of 14 holes and the other set of nine holes, each hole spaced 13 ± 1 mm (0.5 ± 0.04 in.) from the next. Make the holes 1 ± 0.04 mm (0.039 ± 0.002 in.) in diameter.

NOTE 3—It is common for the burner holes to become clogged following a test. Inspect burner head holes after each test and clean thoroughly

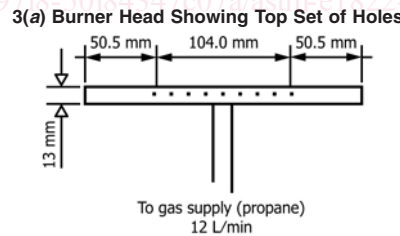
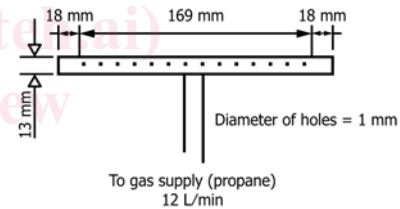

3(b) Burner Head Showing Bottom Set of Holes
To gas supply (propane) 12 L/min

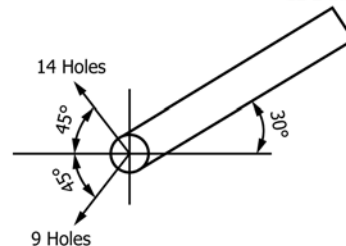

3(c) Side View of Burner Showing Orientation of the Head with the Handle

NOTE 1—See text for tolerances.

FIG. 3 View of T-Shaped Gas Burner

Annex A1, outside the room doorway, such that it collects all of the combustion gases. There shall be no obstructions to the air supply to the test setup.

NOTE 2—Both Type X gypsum wallboard and calcium silicate wallboard with a nominal thickness of at least 13 mm (0.5 in.) have been found acceptable. If the thickness of the wallboard used is greater, it will not affect the results of this test method.

6.1.3 *Open Calorimeter Layout (Test Configuration C):*

6.1.3.1 The area surrounding the test specimen in an open calorimeter layout shall be sufficiently large that there are no heat radiation effects from the walls or any other nearby objects. The airflow to the test specimen shall be symmetrical from all sides.

6.1.3.2 If the heat release rate of the test specimen is below 600 kW, a load cell sited under a hood, and where the distance between the test specimen and any wall is 1 m (3.3 ft) or more, is acceptable.

6.1.3.3 The air supply to the calorimeter shall be sufficient so that it does not affect the burning process.

6.1.4 *General Discussion of Room Layout:*

6.1.4.1 Heat release measurements in the duct, made in Test Configurations A, B, and C have been shown to give similar results for heat release rates below 600 kW (see X1.4) (1).

if required. Take care not to enlarge the holes when cleaning them.

6.2.3 Construct the handle of the burner of stainless steel with the same diameter and thickness as the head. Weld it to the head in the orientation shown in Fig. 3(c). When the 14 holes in the head are oriented 45° above the horizontal and the nine holes are oriented 45° below the horizontal, the handle is approximately 30° above the horizontal. Construct the handle such that it is at least 450 mm (18 in.) long to facilitate its attachment to the support and the propane line.

NOTE 4—To align the burner to the test specimen properly, it is necessary to position the head as described below; therefore, the angle between the handle and the head is not critical.

6.2.4 Use propane gas with a known net heat of combustion of 46.5 ± 0.5 MJ/kg as a fuel for this ignition source. Meter the flow rate of propane at 12 ± 0.25 L/min, at a pressure of 101 ± 5 kPa (standard atmospheric pressure measured at the flow gage), and a temperature of $20 \pm 5^\circ\text{C}$ or at a flow equivalent to these values. Use flexible tubing fed into the handle of the burner to deliver the propane to the burner. Maintain the flow rate constant of propane while the flame is lit. Mount the burner on an adjustable pole, with a counterweight if necessary, to allow the burner to be positioned in the proper location for ignition of the test specimen and then swung out of the way after the propane gas flame is turned off.

6.2.5 The approximate ratio of heat release rate output to gas flow rate is 1.485 kW min/L under standard conditions. Thus, the calculated rate of heat release from the burner at the temperature and pressure given above is 17.8 kW.

6.2.6 Location of Gas Burner:

6.2.6.1 Orient the burner with respect to the test specimen as shown in Fig. 3 (a, b, and c).

6.2.6.2 Ensure that the horizontal plane of the head of the burner (depicted in Fig. 3(c)) is level with the bottom horizontal surface of the lowest chair in the test specimen. This orientation shall be such that the 14 holes are directed at the test specimen at an angle of 45° above the horizontal, and the nine holes are directed under the lowest chair in the test specimen at an angle 45° below the horizontal. The handle will be set, nominally, at 30° above the horizontal.

6.2.6.3 Locate the burner during ignition in such a way that the burner is parallel with the front edge of the lowest chair in the test specimen, 25 ± 2 mm (1 ± 0.1 in.) from the vertical edge of the chair and 50 ± 2 mm (2 ± 0.1 in.) below the bottom horizontal edge of the lowest chair in the test specimen, as shown in Fig. 4.

6.3 Mass Loss Measurements:

6.3.1 Use a weighing platform to measure the mass of the burning test specimen continuously. Construct a weighing platform consisting of a horizontal thermal barrier, as described in 6.3.2, and placed on top of a mass measuring device.

6.3.2 Construct a thermal barrier large enough to prevent melting or falling material from the tested stacked chairs specimen from falling off the thermal barrier. The barrier shall consist of a galvanized steel pan with a gypsum board lining placed on the test specimen. The barrier shall be used to protect the load cell. The pan shall be constructed of nominally 1.6 mm ($\frac{1}{16}$ in.) thick steel, and have dimensions of no less than 1.0 by

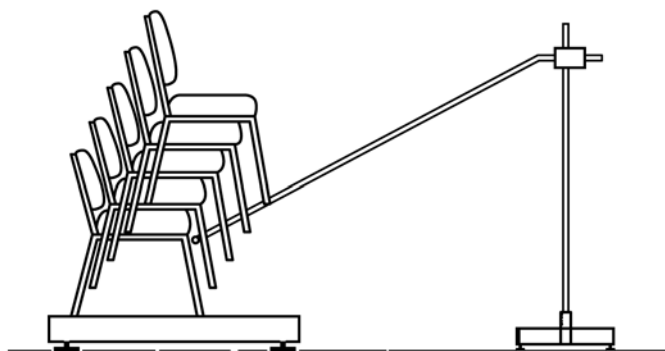

NOTE 1—This example of upholstered chairs has no gaps between the seats or backs. The burner is placed below the bottom of the seat cushion frame.

FIG. 4 Positioning of the Ignition Source—T Burner

1.0 m (39 by 39 in.), with a uniform raised lip of the same material, 100 ± 10 mm (approximately 4 in.) high, on each side, to catch falling material. The bottom of the pan shall be covered by a tight-fitting section of standard gypsum board (finish side up), of nominally 13 mm (0.5 in.) thickness. The gypsum board shall be clean before the start of a test; the board shall be replaced for each test.

6.3.3 Measure the test specimen mass continuously with a device capable of an accuracy of no less than ± 150 g up to at least 90 kg. Install it in such a way that neither the heat from the burning test specimen nor any eccentricity of the load will affect the accuracy. Do not make any range shifts during measurements. Install all parts of the mass measuring device below the top level of the thermal barrier.

6.3.4 The distance from the upper surface of the thermal barrier to floor level shall not exceed 0.3 m (12 in.). The area between the thermal barrier and the floor level shall be shielded by a skirt at the perimeter of the barrier to prevent lifting forces due to fire-induced air flow that influence the measurement.

6.4 Exhaust Collection System:

6.4.1 General:

6.4.1.1 Construct the exhaust collection system with the following minimal requirements: a blower, steel hood, duct, bidirectional probe, thermocouple(s), oxygen measurement system, smoke obscuration measurement system (white light photocell lamp/detector or laser), and combustion gas sampling and analysis system. Construct the exhaust collection system as shown in Fig. 5 and as explained in Annex A1.

6.4.1.2 Ensure that the system for collecting the smoke (that includes gaseous combustion products) has sufficient exhaust capacity and is designed in such a way that all of the combustion products leaving the burning test specimen are collected. Design the capacity of the evacuation system such that it will exhaust minimally all combustion gases leaving the test specimen (see A1.1.4).

6.4.1.3 Place probes for sampling of combustion gas and for measurement of flow rate in accordance with 6.5.

6.4.1.4 Make all measurements of smoke obscuration, gas concentrations, or flow rates at a position in the exhaust duct where the exhaust is mixed uniformly so there is a nearly uniform velocity across the duct section.

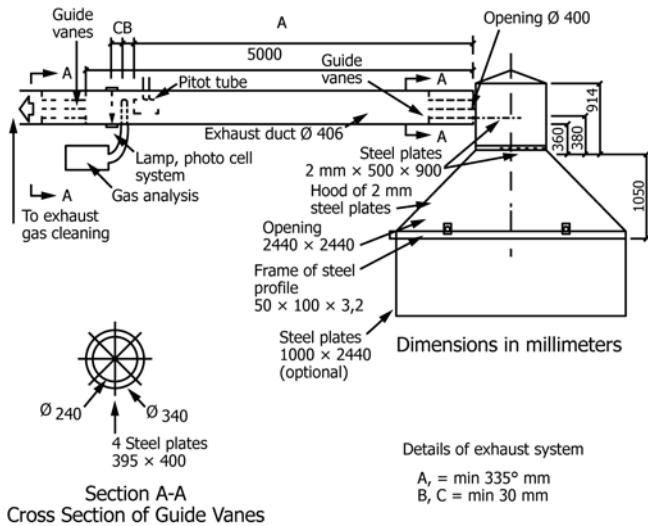

FIG. 5 Design of Hood and Exhaust System

6.4.1.5 To ensure uniform mixing of the exhaust, provide a straight section of duct before the measuring system having a length equal to at least eight times the inside diameter of the duct. If a measuring system is positioned at a distance of less than eight diameters, demonstrate the achievement of equivalent results.

6.5 Instrumentation in Exhaust Duct:

6.5.1 The following specifications are minimum requirements for exhaust duct instrumentation. Additional information is given in Annex A2.

6.5.2 Flow Rate—Measure the flow rate in the exhaust duct by a bidirectional probe or an equivalent measuring system with an accuracy of at least $\pm 6\%$ (see Annex A2). The response time to a stepwise change of the duct flow rate shall not exceed 5 s to reach 90 % of the final value.

6.6 Combustion Gas Analysis:

6.6.1 Sampling Line—Construct the sampling line tubes of a material not influencing the concentration of the combustion gas species to be analyzed. The following sequence of the gas train has been shown to be acceptable: sampling probe, soot

filter, cold trap, gas path pump, vent valve, plastic drying column and carbon dioxide removal columns (if used), flow controller, and oxygen analyzer (see Fig. 6 and Annex A2). Alternative designs of the sampling line must yield equivalent results. The gas train shall also include appropriate spanning and zeroing facilities.

6.6.2 Oxygen Measurement—Measure the oxygen concentration with an accuracy of ± 0.01 vol % oxygen, or better, in order to have adequate measurements of rate of heat release. Take the combustion gas sample from the end of the sampling line. Calculate the time delay, including the time constant of the instrument, from the test room; it is a function of the exhaust duct flow rate. This time delay shall not exceed 60 s (see Annex A2).

6.6.3 Carbon Monoxide and Carbon Dioxide Measurement—Measure the combustion gas species with an instrument having an accuracy of at least ± 0.1 vol % for carbon dioxide and ± 0.02 vol % for carbon monoxide. A suitable output range is from 0 to 1 vol % for carbon monoxide and from 0 to 6 vol % for carbon dioxide. Take the combustion gas sample from the end of the sampling line. Calculate the time delay, including the time constant of the instrument, from the test room; it is a function of the exhaust duct flow rate. It shall be a maximum of 60 s (see Annex A2).

6.6.4 For optional measurement of other combustion gases see A2.3.3.

6.7 Smoke Obscuration Measurement:

6.7.1 Install an optical system for measurement of the light obscuration across the centerline of the exhaust duct. Determine the optical density of the smoke by measuring the light transmitted with a photometer system consisting of a white light source and a photometer system consisting of a white light source and a photocell/detector or a laser system for measurement of light obscuration across the centerline of the exhaust duct.

6.7.2 One photometer system found suitable consists of a lamp, lenses, an aperture, and a photocell (see Fig. 7 and Annex A2). Construct the system so soot deposits on the optics during a test. Do not reduce the light transmission by more than 5 %.

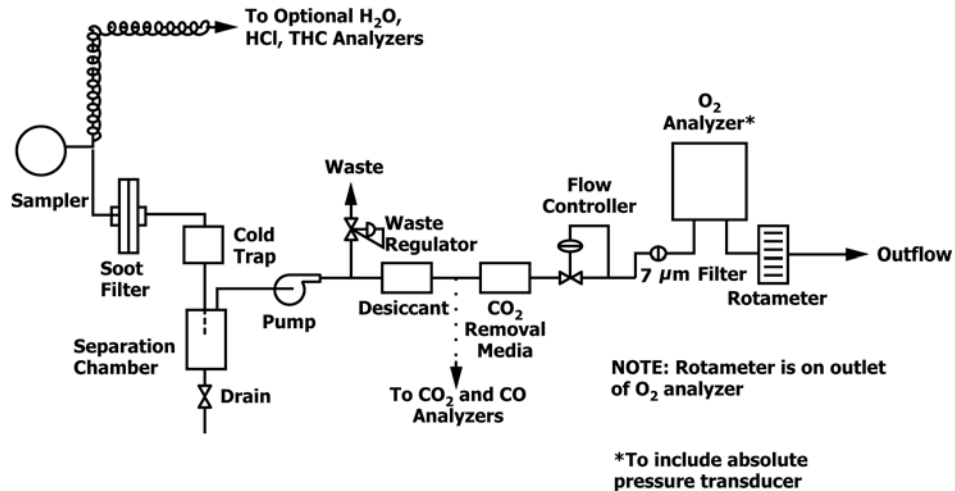

FIG. 6 Schematic of Gas Train

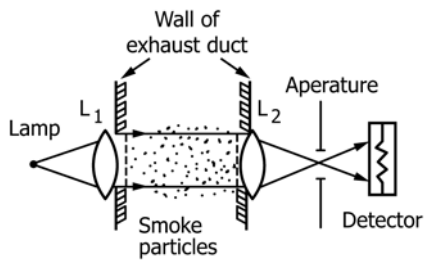

FIG. 7 Optical System Using a White Light

6.7.3 Alternatively, instrumentation constructed using a 0.5 to 2.0 mW helium-neon laser instead of a white-light system is also acceptable (see Fig. 8, Fig. A1.1, and Annex A2). It has been shown that white-light and laser systems will provide similar results (see Refs (2-5)).

7. Test Specimen

7.1 The test specimen is a stack of five identical stacking chairs, or prototype thereof.

7.2 If prototype stacking chairs are used, the prototypes shall, in all respects, reflect the construction of the actual stacking chairs.

7.3 Fire tests of stacking chairs have shown that the fire performance of stacked chairs is significantly affected by chair design and configuration, the gap between adjacent seat surfaces, and the vertical gap between adjacent seat backs. Therefore, it is critical to ensure that the five stacking chairs are carefully stacked in accordance with the design features of the chairs to be tested.

8. Calibration

8.1 Calibrate all instruments carefully with standard sources after initial installation. Among the instruments to be calibrated are load cells or weighing platforms, smoke meters, flow or velocity transducers, and gas analyzers. Perform recalibration tests on the entire system, for example using standard output burners.

8.2 Heat Release:

8.2.1 Perform the calibration of the heat release instrumentation in the exhaust duct by burning propane or methane gas and comparing the heat release rates calculated from the metered gas input and those calculated from the measured oxygen consumption. The value of net heat of combustion for methane is 50.0 MJ/kg and for propane is 46.5 MJ/kg. Position the burner in the same location where the test specimen is to be placed during the test. Measure the gas flow rate at a pressure of 101 ± 5 kPa (standard atmospheric pressure, measured at the flow gage) and a temperature of $20 \pm 5^\circ\text{C}$.

8.2.2 A suitable calibration burner is a sand diffusion burner with a 0.3 by 0.3 m (12 by 12 in.) top surface and a 0.15 m (6 in.) depth. Construct such a gas burner with a 25 mm (1 in.) thick plenum. Alternatively, use a minimum 100 mm (4 in.) layer of Ottawa sand to provide the horizontal surface through which the gas is supplied. This burner is shown in Fig. 9. The gas supply to the burner shall be propane (the same quality used for the ignition burner) or methane. The gas for the burner flame shall not be premixed with air. Meter the flow rate of gas and keep it constant throughout the calibration test.

8.2.3 Another suitable calibration burner is a pipe with an inner diameter of 100 ± 1.5 mm (4 in.) supplied with gas from beneath (see ISO 9705). The gas for the burner flame shall not be premixed with air.

8.2.4 Obtain a minimum of two calibration points. Obtain a lower heat release rate value of 40 kW and then a higher heat release rate value of 160 kW. Approximate propane flow rates for any required heat release rate value are estimated using the following constant: 1.485 kW min/L, determined at a pressure of 101 ± 5 kPa (standard atmospheric pressure; measured at the flow gage) and a temperature of $20 \pm 5^\circ\text{C}$.

8.2.5 Take measurements at least once every 6 s and start 1 min prior to ignition of the burner. Determine the average rate of heat release over a period of at least 1 min by the oxygen consumption method and calculating the heat release rate from the gas mass flow rate and the net heat of combustion. The difference between the two values shall not exceed 5%. This comparison shall be made only after steady-state conditions have been reached.

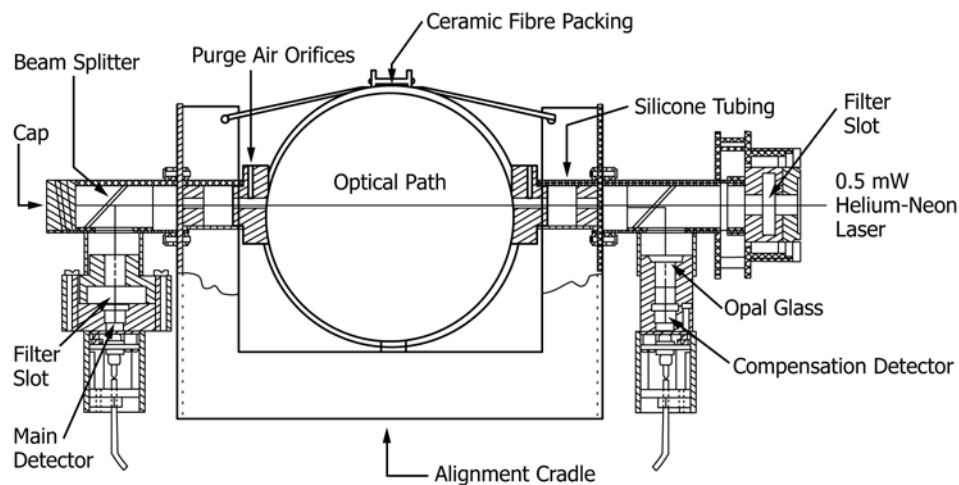
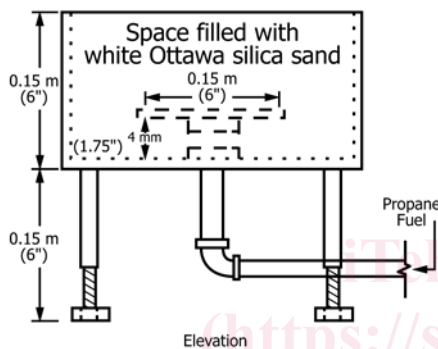
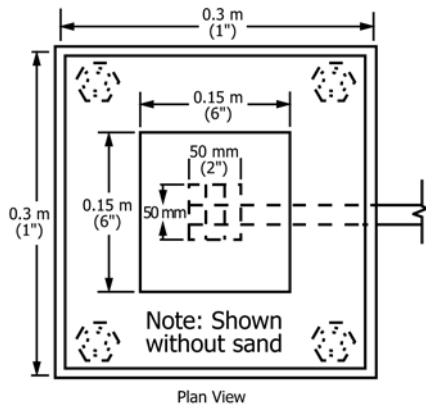

FIG. 8 Laser Extinction Beam



NOTE 1—See text for tolerances.

FIG. 9 Calibration Gas Burner

8.2.6 Perform a calibration test in accordance with 8.5 prior to each continuous test series. Perform a full basic calibration on a new system or when modifications are introduced.

8.2.7 When calibrating a new system, or when modifications are introduced, check the response time of the measuring system by the following test sequence:

Time, min	Burner Output, kW
0-5	0
5-10	40
10-15	160
15-20	0

The response of the system to a stepwise change of the heat output from the burner shall be a maximum of 12 s to 90 % of final value.

8.2.8 Perform the calibration given in 8.2.7 with the initial duct air flow rate equal to that to be used in the test procedure.

8.2.9 The change in measured rate of heat release, comparing time average values over 1 min, shall not be more than 10 % of the actual heat output from the burner.

8.2.10 The use of a higher rate of heat release for calibration, for example 500 kW, will generally lead to higher accuracy in the test results.

8.3 Mass Loss—Perform calibration of the mass-measuring device by loading the weighing platform with known masses corresponding to the measuring range of interest, to ensure that the requirements of accuracy in 6.3.3 are fulfilled. Carry out this calibration daily, prior to testing.

8.4 Smoke Obscuration—Calibrate the smoke meter initially to read correctly for two neutral density filters of significantly different values, and also at 100 % transmission. The use of neutral density filters at 0.5 and 1.0 values of optical density has been shown to be satisfactory for this calibration. Once this calibration is set, only the zero value of extinction coefficient (100 % transmission) must be verified each day, prior to testing. Investigate any excessive departure from the zero line at the end of a test, and correct it.

8.5 Gas Analysis—Calibrate the gas analyzers daily, prior to testing (see Guide E800).

9. Conditioning

9.1 Prior to testing, condition the chairs for at least 48 h in an atmosphere at a temperature of $21 \pm 4^\circ\text{C}$ ($70 \pm 7^\circ\text{F}$) and a relative humidity of less than 60 %. Test the specimen as soon as possible after removal from such conditions if the test room conditions differ from the above. Report the time between removal from the conditioning room and the start of testing.

10. Procedure

10.1 Initial Conditions:

10.1.1 The ambient temperature shall be above 15°C (60°F) and the relative humidity shall be below 75 %.

10.1.2 The horizontal air flow, measured at both the surface and at a horizontal distance of 0.5 m (20 in.) from the edge of the weighing platform, shall not exceed 0.5 m/s^{-1} .

10.1.3 Position the test specimen centrally on the weighing platform.

10.1.4 Have available means for extinguishing a fully developed fire.

10.2 Test Procedure:

10.2.1 Perform the measurements needed to obtain the descriptive information needed for the test report.

10.2.2 Weigh the test specimen immediately upon removal from conditioning room and immediately before the start of test.

10.2.3 Place the T-shaped propane gas burner in front of the test specimen, as specified in 6.2.6. Confirm that burner holes have been cleaned (see Note 3).

10.2.4 Begin all recording and measuring devices 2 min before starting the ignition burner.

10.2.5 Light the ignition burner.

10.2.6 Expose the test specimen to the gas burner flames for 80 s, at a flow rate of 12 L/min, determined at a pressure of $101 \pm 5 \text{ kPa}$ (standard atmospheric pressure, measured at the flow gage) and a temperature of $20 \pm 5^\circ\text{C}$.

10.2.7 Extinguish the gas flame and remove the burner after the specified burning period (80 s).

10.2.8 Perform a photographic or a video recording before and during each test. An indication of elapsed time, giving time to the nearest 1 s, shall appear in all photographic records.

10.2.9 During the test, record the following events and the time when they occur, with respect to the time of ignition of the burner:

10.2.9.1 Ignition of the first igniting chair,

10.2.9.2 Location of the flame front at various appropriate times,

- 10.2.9.3 Melting and dripping,
- 10.2.9.4 Formation of flaming droplets,
- 10.2.9.5 Occurrence of pool fire under the test specimen,
- 10.2.9.6 General description of the burning behavior, and
- 10.2.9.7 Any other event of special interest.
- 10.2.10 Terminate the test after the first of the following:
 - 10.2.10.1 All signs of combustion have ceased,
 - 10.2.10.2 One hour of testing has elapsed, or
 - 10.2.10.3 Flashover appears inevitable.

10.2.11 Note, from visual inspection of the specimen after the test, the approximate percentage of each surface that was burned or charred, and the approximate depth of fire damage.

11. Calculation

11.1 Considerations for heat release measurements are presented in [Annex A3](#). Calculate the heat release data, using the equations presented in [A4.1](#). The testing laboratory shall choose one of the equations given in [A4.1](#) for calculating heat release, based on the gas analyzers installed.

11.2 Calculate the smoke release data using the equations presented in [A4.2](#).

11.3 Calculate the gas yield data using the equations presented in [A4.3](#).

12. Report

12.1 Report the following descriptive information:

- 12.1.1 Name and address of the testing laboratory,
- 12.1.2 Date and identification number of the report,
- 12.1.3 Name and address of the test requester,
- 12.1.4 Test configuration used: A, B, or C,
- 12.1.5 Name of product manufacturer or supplier, if known,
- 12.1.6 Name or other identification marks and description of the chairs,
- 12.1.7 Linear dimensions (height, width, depth) of each individual chair and of the test specimen,
- 12.1.8 Total mass, thickness of the main components and mass of combustible portion of each test specimen,
 - 12.1.8.1 Weight change of the test specimen between removal from conditioning room and start of test,
- 12.1.9 Density, or mass per unit surface area of the main components in each chair, if known,
- 12.1.10 Conditioning of the chairs,
- 12.1.11 Date of the test,
- 12.1.12 Test number and any special remarks, and
- 12.1.13 Time between the removal from conditioning room and start of testing.

12.2 Include the following test results in the test report (see also appendixes):

- 12.2.1 Table of numerical results containing the following:
 - 12.2.1.1 Peak rate of heat release (in kW), and the time at which it occurred,
 - 12.2.1.2 Total heat released (in MJ),
 - 12.2.1.3 Total heat released at 10 min (in MJ),
 - 12.2.1.4 Peak rate of smoke release (in m^2/s^{-1}), and the time at which it occurred,
 - 12.2.1.5 Total smoke released (in m^2),
 - 12.2.1.6 Total smoke released at 10 min (in m^2),
 - 12.2.1.7 Total mass loss (in kg),

- 12.2.1.8 Total mass loss at 10 min (in kg),
- 12.2.1.9 Total percentage of mass loss (in %),
- 12.2.1.10 Peak concentration of carbon monoxide (in ppm),
- 12.2.1.11 Peak temperatures (in °C),
- 12.2.1.12 Equation used to calculate rate of heat release,
- 12.2.1.13 Peak optical density of smoke (optional),
- 12.2.1.14 Average optical density of smoke, over the 10-min period including the peak (optional),
- 12.2.1.15 Total percentage of combustible mass loss (in %) (optional),
- 12.2.1.16 Average yield of carbon monoxide (in g CO/g fuel) (optional),
- 12.2.1.17 Average yield of carbon dioxide (in g CO₂/g fuel) (optional),
- 12.2.1.18 Carbon monoxide/carbon dioxide molar yield ratio (optional), and
- 12.2.1.19 Average yield of any other measured combustion gas (in g combustion gas/g fuel) (optional).

12.2.2 Graphical Results (Optional):

- 12.2.2.1 Plot of rate of heat release versus time,
- 12.2.2.2 Plot of rate of smoke release versus time,
- 12.2.2.3 Plot of optical density versus time,
- 12.2.2.4 Plot of mass loss versus time,
- 12.2.2.5 Plot of concentration of carbon monoxide versus time,
- 12.2.2.6 Plot of concentration of carbon dioxide versus time,
- 12.2.2.7 Plots of concentration of any other measured combustion gas versus time,
- 12.2.2.8 Plot of mass flow rate in the exhaust duct versus time,
- 12.2.2.9 Plot of duct temperature versus time, and
- 12.2.2.10 Report smoke obscuration, carbon monoxide and temperature measurements in the room in the same fashion, if they have been made.

12.2.3 Descriptive Results:

- 12.2.3.1 Photographs or videotape of the fire development, and
- 12.2.3.2 All available information requested in [10.2.9](#) through [10.2.11](#).

13. Precision and Bias

13.1 Precision:

13.1.1 *Initial Repeatability*—The results of a repeatability study from one laboratory, involving six different sets of stacked chairs are shown in [Table 1](#) and [Table X4.1](#) to [Table X4.6](#). Three tests were conducted for each type of stacking chair in Test Configuration C (furniture calorimeter). The percentage relative standard deviation or coefficient of variation (100 times the ratio of the standard deviation and the average) for various properties (initial mass, peak heat release rate, total heat release, peak smoke release rate, total smoke release, mass loss, and time to peak heat release rate) were averaged for all tests (see [Table 1](#)). The constant (A) and coefficient (B) correspond to the terms in the equation:

$$\text{Repeatability } (r) = A + B * \text{property} \quad (1)$$

TABLE 1 Stacking Chair Test Results—Chair Set 6 (See X4.6)

NOTE 1—A and B represent the constant and coefficient of the equation:

$$r \text{ (repeatability)} = A + B^* \text{ property}$$

NOTE 2—RSD % and Avg represent the averages of, respectively, the percentage relative standard deviations and average values for every type of stack tested.

	Initial Mass, kg	Peak Heat Release Rate, kW	Total Heat Released, MJ	Peak Smoke Release Rate, m ² /s	Total Smoke Released, m ²	Mass Loss, kg	Time to Peak Heat Release Rate, min
A	0.14	-79	41	0.48	163	0.30	-0.59
B	0.011	0.25	-0.065	-0.0058	0.022	0.075	0.26
Avg	37.7	863	265	5.1	1235	9.6	12.1
RSD%	1	14	14	17	18	16	20

The results shows that the average of the relative standard deviations is less than 25 % for all properties analyzed, although some individual relative standard deviations also exceed 20 %.

13.1.2 *Interlaboratory Repeatability and Reproducibility*—**Table 2** and **Table 3** show the precision obtained in an interlaboratory round-robin evaluation conducted with 4 laboratories, using three sets of stacking chairs (labeled S1 to S3), stacked in groups of 5 for test, supplied by different manufacturers, and all commercially available. Two of the laboratories conducted the tests using the “ASTM room,” and the other two used the “California room.” The data obtained from all four laboratories were analyzed. In **Table 2**, outliers and “obviously incorrect data” were excluded, using standard statistical considerations and information from the test lab reports submitted. It should be noted that some tests in some laboratories were incorrectly terminated before the mandated end point, after some guidelines were exceeded. The complete set of major data was also analyzed, without eliminating any data point, with the statistical analysis included as **Table 3**. It is possible to conduct an analysis of the data that excludes all incorrect data but does not exclude outliers, but that was not done. A Research Report has been submitted to ASTM which includes all the information required for a full understanding of results. The user is encouraged to consult this research report

entitled: “Test Methods E1537 & E1822 Interlaboratory Precision Study, Prepared by: ASTM E05.15” (2001). The abbreviations used are as follows: peak rate of heat release (Pk RHR), total heat released (THR), mass loss at 10 min (Mass Loss @ 10), peak rate of smoke release (Pk RSR), total smoke released (RSR), standard deviation for repeatability and reproducibility (STD repeat and STD Repro), relative standard deviation for repeatability and reproducibility (RSD repeat and RSD Repro), repeatability (r) and Reproducibility (Repro).

13.2 Bias:

13.2.1 No information is presented on the bias of the procedure in this test method because correct values of fire-test-response characteristics of stacked chairs can only be defined in terms of a test method. Within this limitation, this test method has no known bias and is acceptable as a reference test method.

13.2.2 For solid test specimens of unknown chemical composition, as used in building materials, furnishings, and common occupant fuel load, it has been documented that the use of the oxygen consumption standard value of 13.1 MJ/kg oxygen for the net amount of heat released per unit of oxygen consumed for complete consumption, results in an expected error band of $\pm 5\%$ compared to the true value. For homogeneous materials with only a single pyrolysis mechanism, this

TABLE 2 Intralaboratory and Interlaboratory Precision Results of Round Robin Evaluation Excluding Outliers and Incorrect Data

Stack	Property/Units	Average	STD repeat	STD Repro	r	R	RSD repeat	RSD Repro
S1	Pk RHR/kW	14.7	4.3	4.3	12.0	12.0	29.2	29.2
S2	Pk RHR/kW	23.6	8.7	8.7	24.5	24.5	37.0	37.0
S3	Pk RHR/kW	503.4	156.4	156.4	437.8	437.8	31.1	31.1
S1	THR @ 10/MJ	1.7	1.6	1.6	4.4	4.4	94.4	94.4
S2	THR @ 10/MJ	3.8	2.1	2.1	5.8	5.8	53.8	53.8
S3	THR @ 10/MJ	70.8	39.8	39.8	111.6	111.6	56.3	56.3
S1	time to Pk RHR/s	110.9	29.9	64.7	83.8	181.1	27.0	58.3
S2	time to Pk RHR/s	436.0	745.2	745.2	2086.5	2086.5	170.9	170.9
S3	time to Pk RHR/s	595.5	131.2	131.2	367.3	367.3	22.0	22.0
S1	Mass Loss @ 10/kg	0.2	0.3	0.3	0.8	0.8	167.0	167.0
S2	Mass Loss @ 10/kg	0.3	0.1	0.2	0.4	0.6	49.9	75.6
S3	Mass Loss @ 10/kg	7.2	2.4	2.4	6.6	6.6	32.6	32.6
S1	Pk RSR, m ² /s	0.6	1.1	1.1	3.1	2.1	174.3	174.3
S2	Pk RSR, m ² /s	1.0	0.7	0.9	1.9	2.4	67.7	85.1
S3	Pk RSR, m ² /s	1.9	0.7	0.7	2.0	2.0	37.0	37.0
S1	TSR, m ²	91.6	45.4	78.3	127.1	219.3	49.6	85.5
S2	TSR, m ²	78.2	61.1	64.5	171.1	180.6	78.1	82.4
S3	TSR, m ²	697.1	210.1	350.1	588.2	980.3	30.1	50.2
S1	time to Pk RSR/s	119.9	45.1	45.1	126.3	126.3	137.6	137.6
S2	time to Pk RSR/s	82.9	6.0	6.0	16.9	16.9	7.3	7.3
S3	time to Pk RSR/s	793.2	955.8	955.8	2676.3	2676.3	120.5	120.5