



Designation: G176 – 03 (Reapproved 2017)

# Standard Test Method for Ranking Resistance of Plastics to Sliding Wear Using Block-on-Ring Wear Test—Cumulative Wear Method<sup>1</sup>

This standard is issued under the fixed designation G176; the number immediately following the designation indicates the year of original adoption or, in the case of revision, the year of last revision. A number in parentheses indicates the year of last reapproval. A superscript epsilon ( $\epsilon$ ) indicates an editorial change since the last revision or reapproval.

## 1. Scope

1.1 This test method covers laboratory procedures for determining the resistance of plastics to sliding wear. The test utilizes a block-on-ring friction and wear testing machine to rank plastics according to their sliding wear characteristics against metals or other solids.

1.2 An important attribute of this test is that it is very flexible. Any material that can be fabricated into, or applied to, blocks and rings can be tested. Thus, the potential materials combinations are endless. In addition, the test can be run with different gaseous atmospheres and elevated temperatures, as desired, to simulate service conditions.

1.3 Wear test results are reported as the volume loss in cubic millimetres for the block and ring. Materials of higher wear resistance will have lower volume loss.

1.4 The values stated in SI units are to be regarded as the standard. The values given in parentheses are for information only.

1.5 *This standard does not purport to address all of the safety concerns, if any, associated with its use. It is the responsibility of the user of this standard to establish appropriate safety, health, and environmental practices and determine the applicability of regulatory limitations prior to use.*

1.6 *This international standard was developed in accordance with internationally recognized principles on standardization established in the Decision on Principles for the Development of International Standards, Guides and Recommendations issued by the World Trade Organization Technical Barriers to Trade (TBT) Committee.*

<sup>1</sup> This test method is under the jurisdiction of ASTM Committee G02 on Wear and Erosion and is the direct responsibility of Subcommittee G02.40 on Non-Abrasive Wear.

Current edition approved Nov. 1, 2017. Published December 2017. Originally approved in 2003. Last previous edition approved in 2009 as G176 – 03 (2009). DOI: 10.1520/G0176-03R17.

## 2. Referenced Documents

### 2.1 ASTM Standards:<sup>2</sup>

- D618 Practice for Conditioning Plastics for Testing
- D2714 Test Method for Calibration and Operation of the Falex Block-on-Ring Friction and Wear Testing Machine
- E122 Practice for Calculating Sample Size to Estimate, With Specified Precision, the Average for a Characteristic of a Lot or Process
- E177 Practice for Use of the Terms Precision and Bias in ASTM Test Methods
- E691 Practice for Conducting an Interlaboratory Study to Determine the Precision of a Test Method
- G40 Terminology Relating to Wear and Erosion
- G77 Test Method for Ranking Resistance of Materials to Sliding Wear Using Block-on-Ring Wear Test

## 3. Terminology

### 3.1 Definitions:

3.1.1 *wear*—damage to a solid surface, generally involving progressive loss of material, due to relative motion between that surface and a contacting substance or substances. **G40**

## 4. Summary of Test Method

4.1 A test plastic block is loaded against a metal test ring that rotates at a given speed for a given number of revolutions. Block scar volume is calculated from the block scar width. The friction force required to keep the block in place may be continuously measured during the test with a load cell. When this is done, the friction force data are combined with normal force data to obtain values for the coefficient of friction and reported.

## 5. Significance and Use

5.1 The significance of this test method in any overall measurement program directed toward a service application will depend on the relative match of test conditions to the conditions of the service application.

<sup>2</sup> For referenced ASTM standards, visit the ASTM website, www.astm.org, or contact ASTM Customer Service at service@astm.org. For *Annual Book of ASTM Standards* volume information, refer to the standard's Document Summary page on the ASTM website.

5.2 This test method prescribes the test procedure and method of calculating and reporting data for determining the sliding wear resistance of plastics, using cumulative volume loss.

5.3 The intended use of this test is for coarse screening of plastics in terms of their resistance to sliding wear.

## 6. Apparatus and Test Specimens

6.1 *Test Schematic*—A schematic of the block-on-ring wear test geometry is shown in Fig. 1. In the figure, the friction load cell is enlarged.

6.2 *Test Ring*—A typical test ring is shown in Fig. 2. The test ring must have an outer diameter of  $34.99 \pm 0.025$  mm ( $1.377 \pm 0.001$  in.) with an eccentricity between the inner and outer surfaces of no greater than 0.00125 mm (0.0005 in.). For couples where surface condition is not under study, it is recommended that the outer diameter be a ground surface with a roughness of 0.152 to 0.305  $\mu\text{m}$  (6 to 12  $\mu\text{in.}$ ) rms or center line average (CLA), in the direction of motion. However, alternate surface conditions may be evaluated in the test, as desired. It should be kept in mind that surface condition can have an effect on sliding wear results.

NOTE 1—A commonly used test ring is a carburized 4620 steel having a hardness of 60 HRC or higher.

6.3 *Test Block*—A test block is shown in Fig. 3. Block width is  $6.35 + 0.000, -0.025$  mm ( $0.250 + 0.000, -0.001$  in.).

6.4 *Optical Device (or equivalent)*, with metric or English unit calibration, is also necessary so that scar width can be measured with a precision of 0.01 mm (0.0004 in.) or equivalent.

## 7. Reagents

7.1 Reagents may include the following:

NOTE 2—Organic cleaners should be used with caution as they may react with the plastic being tested.

7.1.1 *Methanol.*

7.1.2 *Eye Glass Cleaner.*

## 8. Preparation and Calibration of Apparatus

8.1 Run the calibration procedure that is in Test Method D2714 to ensure good mechanical operation of the test equipment.

## 9. Procedure

9.1 Condition the test specimens at  $23 \pm 2^\circ\text{C}$  ( $73.4 \pm 3.6^\circ\text{F}$ ) and  $50 \pm 5\%$  relative humidity for not less than 40 h

prior to testing in accordance with Procedure A of Practice D618 for those samples where conditioning is required.

9.2 The recommended test conditions are the standard laboratory atmosphere of  $23 \pm 2^\circ\text{C}$  ( $73.4 \pm 3.6^\circ\text{F}$ ) and  $50 \pm 5\%$  relative humidity.

9.3 Clean the ring using a procedure that will remove any scale, oil film, or residue without damaging the surface. The following procedure is recommended: clean the ring in a suitable solvent, ultrasonically, if possible; a methanol rinse may be used to remove any traces of solvent residue. Allow the rings to dry completely. Handle the ring with clean, lint-free cotton gloves from this point on.

9.4 For the plastic block, the following cleaning procedure is recommended: Clean the plastic block with methanol. Allow the blocks to dry completely. After cleaning, handle the block with clean, lint-free cotton gloves. Other procedures may be used provided they do not affect the plastic. If an application under study uses a plastic in the molded condition, it is advised to test a block with the test surface in the molded condition. The wear of a molded surface may be different from the wear of a machined surface.

9.5 Make surface texture and surface roughness measurements across the width of the ring, as necessary. Note that a surface profile does not completely describe a surface topology. Scanning electron micrographs may be used, as desired, to augment the description of the wear surfaces. Clean the ring again, if necessary, as in 9.3.

9.6 Demagnetize the ring and ferrous assembly.

9.7 Measure the block width and ring diameter to the nearest 0.025 mm (0.001 in.).

9.8 Clean the self-aligning block holder, ring shaft, and surrounding fixtures with solvent.

9.9 Put the self-aligning block holder on the block. Apply a thin layer of lubricant to the self-aligning holder. Use of a non-migrating product is suggested.

9.10 Place the block in position on the machine and, while holding the block in position, place the ring on the shaft and lock the ring in place, using a method in accordance with the requirements of the specific machine design.

9.11 Center the block on the ring while placing a light manual pressure on the lever arm to bring the block and ring into contact. Be sure the edge of the block is parallel to the edge of the ring and that the mating surfaces are perfectly aligned. This is accomplished by making sure the specimen holder is free during mounting so that the quarter segment can properly seat itself. Release the pressure on the lever arm.

9.12 Place the required weights on the load bale and adjust the lever arm in accordance with the requirements of the specific machine design to provide a load of 44.3 N (10 lbf) at the block/ring interface. Then remove the load by raising the weights.

9.13 Set the revolution counter to zero.

9.14 Gently lower the weights to apply the required load.

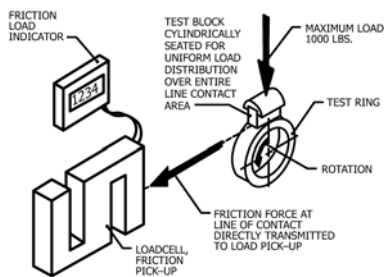

FIG. 1 Test Schematic

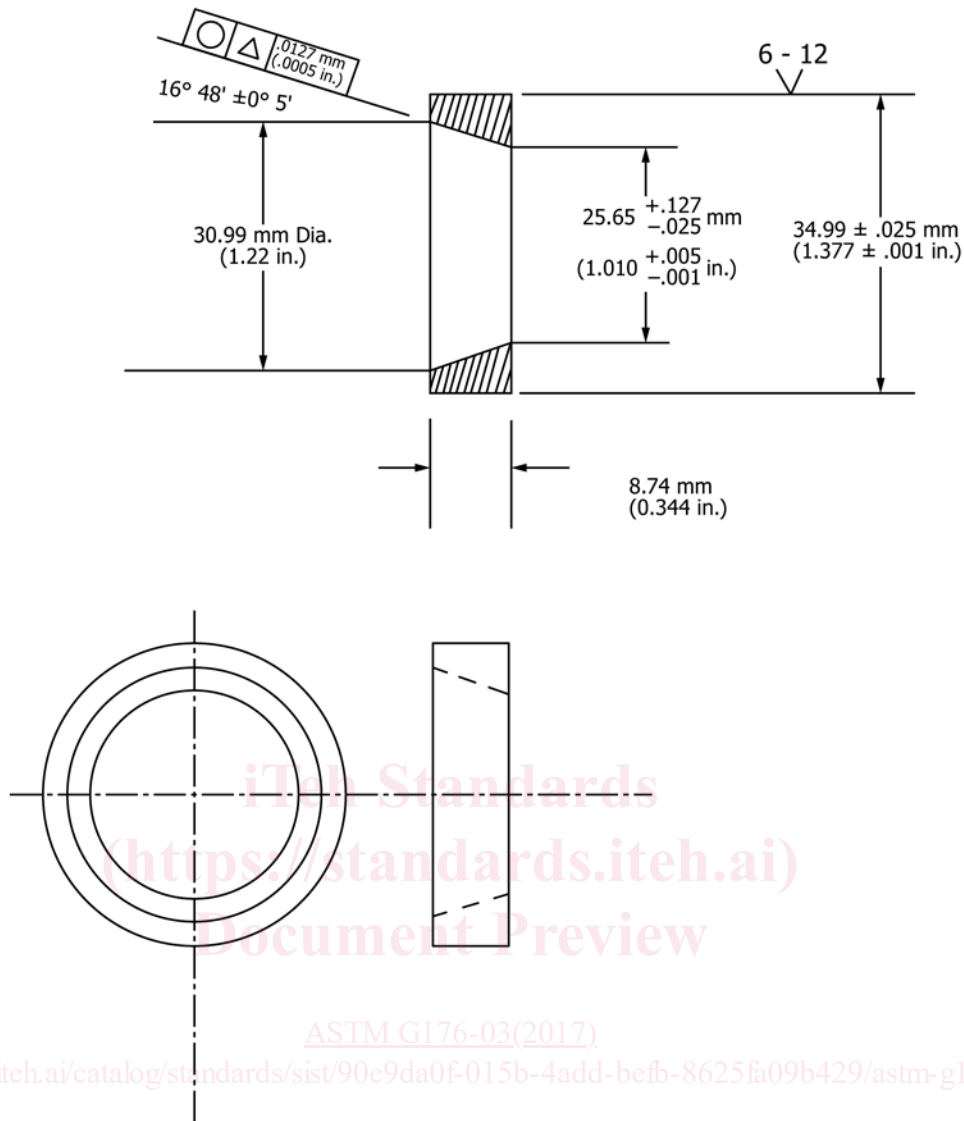

FIG. 2 Test Ring

NOTE 1—The outer diameter and concentricity with the inner diameter are the only critical parameters. The inner diameter is optional depending on machine design. The inside diameter taper shown fits a number of standard machines.

9.15 If using a variable speed machine, turn on the machine and slowly increase the power to the drive motor until the ring starts to rotate, and record the “static” friction force. Continue to increase the rate of rotation to 200 rpm. If using a fixed speed machine, simply turn on the machine.

9.16 During the test, record the friction force.

9.17 Stop the test manually or automatically after 240 000 revolutions (20 h).

9.18 A final “static” friction force may be measured with a variable speed machine. Leaving on the full load, wait  $3 \text{ min} \pm 10 \text{ s}$ , then turn on the machine and slowly increase the power to the drive motor until the ring starts to rotate, recording the final “static” friction force. Then turn off the motor.

9.19 Remove the block and ring and clean. For metals, use a suitable solvent. For plastics, remove loose debris with a dry soft brush.

9.20 Make surface roughness measurements and profilometer traces across the width of the block and the ring as desired. A trace along the long axis of the block, through the wear scar, is also useful to verify the scar depth and shape.

9.21 Measure the scar width on the test block in the center and  $\sim 1 \text{ mm}$  ( $0.04 \text{ in.}$ ) away from each edge. These measurements shall be to the nearest  $0.01 \text{ mm}$  ( $0.0004 \text{ in.}$ ). Record the average of the three readings. Sometimes a lip of plastically deformed material will extend over the edge of the wear scar.

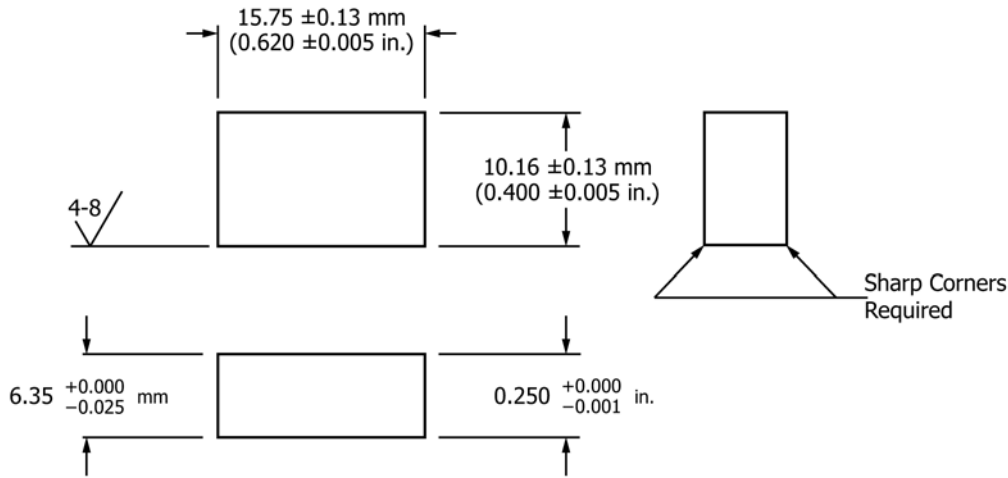

FIG. 3 Test Block  
FIG. 3 Test Block

When measuring scar width, try to visually ignore this material or measure the scar width in an area where this is not a problem.

9.22 Tapered scars indicate improper block alignment during testing. If the three width measurements on a given block have a coefficient of variation of greater than 10 %, the test shall be declared invalid. For further discussion of measurement problems see 9.21, 9.22, and Fig. 4 in Test Method G77.

## 10. Calculation

### 10.1 Calculation of Block Scar Volume:

10.1.1 Block scar volume may be derived from block scar width by using Table 1 (applicable only when ring diameter is  $34.99 \pm 0.025$  mm ( $1.377 \pm 0.001$  in.) and scar length (block width) is  $6.35 + 0.000, -0.025$  mm ( $0.250 + 0.000, -0.001$  in.)).

10.1.2 The preferred method of calculating block scar volume is by using the formula shown in Fig. 4. This formula may be programmed on a calculator or computer.

10.1.3 Block scar volume is not calculated generally from block mass loss because block mass is subject to effects of material transfer. Keeping this in mind, block mass loss may be interpreted semi-quantitatively in a comparative evaluation of various material couples. If the block scar cannot be accurately measured following 9.21, a scar volume should not be calculated, but a notation made of the problem, for example, material transfer, plastic deformation, and so forth.

10.2 Calculate coefficient of friction values from friction force values as follows:

$$f = \frac{F}{W} \quad (1)$$

where:

- $f$  = coefficient of friction,
- $F$  = measured friction force, N (lbf), and
- $W$  = applied load, 44.3 N (10 lbf).

10.3 Calculate ring volume loss as follows:

$$\text{volume loss} = \frac{\text{ring mass loss}}{\text{ring density}} \quad (2)$$

10.3.1 If the ring gains mass during the test, the volume loss is reported as zero with a notation that weight gain occurred. Ring mass loss can be affected by transfer of the plastic to the metal surface. If plastic transfer to the ring is obvious, then a ring scar volume should not be calculated from the weight loss measurement, but a notation should be made that plastic transfer occurred. If there are obvious signs of abrasion of the ring surface, such as scratches or grooving, this should also be noted. In this case profilometry may be used to measure material loss.

## 11. Report

11.1 Report any unusual event or an overload shutoff of the machine (on some machines it is possible to have an automatic shutoff at a preset frictional load). If the machine malfunctions or a test block has a tapered scar, the data shall not be used, and the test shall be rerun.

11.2 Report the following:

### 11.2.1 Test Parameters:

- 11.2.1.1 Block material,
- 11.2.1.2 Ring material and hardness (whenever applicable),
- 11.2.1.3 Ring and block initial surface roughness, and
- 11.2.1.4 Number of replicates.

11.2.2 Results—Report the average and the coefficient of variation of the following (the coefficient of variation is the standard deviation divided by the average; it is expressed as a percent).

- 11.2.2.1 Block scar width, mm,
- 11.2.2.2 Block scar volume,  $\text{mm}^3$ , calculated from scar width, and
- 11.2.2.3 Ambient conditions, if other than normal laboratory conditions.

### 11.2.3 Reporting Optional:

- 11.2.3.1 Final surface roughness of block and ring,
- 11.2.3.2 Ring heat treatment, and