



Designation: **D4945 – 12 D4945 – 17**

## Standard Test Method for High-Strain Dynamic Testing of Deep Foundations<sup>1</sup>

This standard is issued under the fixed designation D4945; the number immediately following the designation indicates the year of original adoption or, in the case of revision, the year of last revision. A number in parentheses indicates the year of last reappraisal. A superscript epsilon ( $\epsilon$ ) indicates an editorial change since the last revision or reappraisal.

### 1. Scope-Scope\*

1.1 This dynamic test method covers the procedure for applying an axial impact force with a pile driving hammer or a large drop weight that will cause a relatively high strain at the top of an individual vertical or inclined deep foundation unit, and for measuring the subsequent force and velocity response of that deep foundation unit. While in this standard force and velocity are referenced as “measured,” they are typically derived from measured strain and acceleration values. High-strain dynamic testing applies to any deep foundation unit, also referred to herein as a “pile,” which functions in a manner similar to a driven pile or a cast-in-place pile regardless of the method of installation, and which conforms with the requirements of this test method.

1.2 This standard provides minimum requirements for dynamic testing of deep foundations. Plans, specifications, or provisions (or combinations thereof) prepared by a qualified engineer may provide additional requirements and procedures as needed to satisfy the objectives of a particular test program. The engineer in responsible charge of the foundation design, referred to herein as the “Engineer”, shall approve any deviations, deletions, or additions to the requirements of this standard.

1.3 The proper conduct and evaluation of high-strain dynamic tests requires special knowledge and experience. A qualified engineer should directly supervise the acquisition of field data and the interpretation of the test results so as to predict the actual performance and adequacy of deep foundations used in the constructed foundation. A qualified engineer shall approve the apparatus used for applying the impact force, driving appurtenances, test rigging, hoist equipment, support frames, templates, and test procedures.

1.4 The text of this standard references notes and footnotes which provide explanatory material. These notes and footnotes (excluding those in tables and figures) shall not be considered as requirements of the standard. The word “shall” indicates a mandatory provision, and the word “should” indicates a recommended or advisory provision. Imperative sentences indicate mandatory provisions.

1.5 Units—The values stated in SI units are to be regarded as standard. No other units of measurement are included in this standard. Reporting of test results in units other than SI shall not be regarded as nonconformance with this test method.

1.6 All observed and calculated values shall conform to the guidelines for significant digits and rounding established in Practice **D6026**.

1.6.1 The procedures used to specify how data are collected/recorded and calculated in this standard are regarded as the industry standard. In addition, they are representative of the significant digits that should generally be retained. The procedures used do not consider material variation, purpose for obtaining the data, special purpose studies, or any considerations for the user’s objectives; and it is common practice to increase or reduce significant digits of reported data to commensurate with these considerations. It is beyond the scope of this standard to consider significant digits used in analysis methods for engineering design.

1.7 The method used to specify how data are collected, calculated, or recorded in this standard is not directly related to the accuracy to which the data can be applied in design or other uses, or both. How one applies the results obtained using this standard is beyond its scope.

1.7 *This standard does not purport to address all of the safety concerns, if any, associated with its use. It is the responsibility of the user of this standard to establish appropriate safety-safety, health, and healthenvironmental practices and determine the applicability of regulatory limitations prior to use.* For a specific precautionary statement, see **Note 4**.

1.8 *This international standard was developed in accordance with internationally recognized principles on standardization established in the Decision on Principles for the Development of International Standards, Guides and Recommendations issued by the World Trade Organization Technical Barriers to Trade (TBT) Committee.*

<sup>1</sup> This test method is under the jurisdiction of ASTM Committee **D18** on Soil and Rock and is the direct responsibility of Subcommittee **D18.11** on Deep Foundations. Current edition approved ~~May 1, 2012~~Nov. 1, 2017. Published ~~June 2012~~December 2017. Originally approved in 1989. Last previous edition approved in ~~2008~~2012 as ~~D4945 – 08~~D4945 – 12. DOI: ~~10.1520/D4945-12~~10.1520/D4945-17.

\*A Summary of Changes section appears at the end of this standard

## 2. Referenced Documents

### 2.1 ASTM Standards:<sup>2</sup>

- C469 Test Method for Static Modulus of Elasticity and Poisson's Ratio of Concrete in Compression
- D198 Test Methods of Static Tests of Lumber in Structural Sizes
- D653 Terminology Relating to Soil, Rock, and Contained Fluids
- D1143/D1143M Test Methods for Deep Foundations Under Static Axial Compressive Load
- D3689 Test Methods for Deep Foundations Under Static Axial Tensile Load
- D3740 Practice for Minimum Requirements for Agencies Engaged in Testing and/or Inspection of Soil and Rock as Used in Engineering Design and Construction
- D6026 Practice for Using Significant Digits in Geotechnical Data

## 3. Terminology

3.1 ~~Definitions—Definitions:~~ For common definitions of terms used in this standard, see Terminology **D653**.

3.1.1 For definitions of common technical terms in this standard, refer to Terminology **D653**.

3.2 *Definitions of Terms Specific to This Standard:*

3.2.1 *cast in-place pile, n*—a deep foundation unit made of cement grout or concrete and constructed in its final location, for example, drilled shafts, bored piles, caissons, auger cast piles, pressure-injected footings, etc.

3.2.2 *deep foundation, n*—a relatively slender structural element that transmits some or all of the load it supports to the soil or rock well below the ground surface, that is, a driven pile, a cast-in-place pile, or an alternate structural element having a similar function.

3.2.3 *deep foundation cushion, n*—the material inserted between the helmet on top of the deep foundation and the deep foundation (usually plywood).

3.2.4 *deep foundation impedance, n*—a measure of the deep foundation's resistance to motion when subjected to an impact event. ~~Deep foundation impedance can be calculated by multiplying the cross-sectional area by the dynamic modulus of elasticity and dividing the product by the wave speed. Alternatively, the impedance can be calculated by multiplying the mass density by the wave speed and cross-sectional area.~~

$$Z = (EA/c) = \rho cA \quad (1)$$

where:

- $Z$  = impedance;
- $E$  = dynamic modulus of elasticity;
- $A$  = cross-sectional area;
- $c$  = wave speed, and
- $\rho$  = mass density.

### 3.2.4.1 *Discussion—*

Deep foundation impedance can be estimated by multiplying the cross-sectional area by the dynamic modulus of elasticity and dividing the product by the wave speed. Alternatively, the impedance can be estimated by multiplying the mass density by the wave speed and cross-sectional area.

$$Z = (EA/c) = \rho cA \quad (1)$$

where:

- $Z$  = impedance,
- $E$  = dynamic modulus of elasticity,
- $A$  = pile cross-sectional area,
- $c$  = wave speed, and
- $\rho$  = mass density.

3.2.5 *driven pile, n*—a deep foundation unit made of preformed material with a predetermined shape and size and typically installed by impact hammering, vibrating, or pushing.

3.2.6 *follower, n*—a structural section placed between the impact device and the deep foundation during installation or testing.

3.2.7 *hammer cushion, n*—the material inserted between the hammer striker plate and the helmet on top of the deep foundation.

<sup>2</sup> For referenced ASTM standards, visit the ASTM website, www.astm.org, or contact ASTM Customer Service at service@astm.org. For *Annual Book of ASTM Standards* volume information, refer to the standard's Document Summary page on the ASTM website.

3.2.8 *impact event, n*—the period of time during which the deep foundation is moving due to the impact force application. See Fig. 1.

3.2.9 *impact force, n*—in the case of strain transducers, the transient the impact force is obtained by multiplying the measured strain ( $\epsilon$ ) with the cross-sectional area (force applied to the top A) and the dynamic modulus of elasticity (of the deep foundation) element.

3.2.10 *mandrel, n*—a stiff structural member placed inside a thin shell to allow impact installation of the thin section shell.

3.2.11 *moment of impact, n*—the first time after the start of the impact event when the acceleration is zero. See Fig. 1.

3.2.12 *particle velocity, n*—the instantaneous velocity of a particle in the deep foundation as a strain wave passes by.

3.2.13 *restrike, n or v*—the re-driving of a previously driven pile, typically after a waiting period of 15 min to 30 days or more, to assess changes in ultimate axial compressive static capacity during the time elapsed after the initial installation.

3.2.14 *wave speed, n*—the speed with which a strain wave propagates through a deep foundation. It is a property of the deep foundation composition and for one-dimensional wave propagation is equal to the square root of the quotient of the Modulus of Elasticity divided by mass density:  $c = (E/\rho)^{1/2}$ .

3.2.14.1 *Discussion—*

The wave speed is a property of the deep foundation composition and for one-dimensional wave propagation is equal to the square root of the quotient of the Modulus of Elasticity divided by mass density:  $c = (E/\rho)^{1/2}$ . For wood and concrete piles, the wave speed is the average wave speed over the pile length.

4. Significance and Use

4.1 Based on the measurements from strain or force, and acceleration, velocity, or displacement transducers, this Test method obtains the force and velocity induced in a pile during an axial impact event (see Figs. 1 and 2). Force and velocity are typically derived from measured strain and acceleration. The Engineer may analyze the acquired data using engineering principles and judgment to evaluate the integrity of the pile, the performance of the impact system, and the maximum compressive and tensile stresses occurring in the pile.

4.2 If sufficient axial movement occurs during the impact event, and after assessing the resulting dynamic soil response along the side and bottom of the pile, the Engineer may analyze the results of a high-strain dynamic test to estimate the ultimate axial static compression capacity (see Note 1). Factors that may affect the axial static capacity estimated from dynamic tests include, but are not limited to the: (1) pile installation equipment and procedures, (2) elapsed time since initial installation, (3) pile material properties and dimensions, (4) type, density, strength, stratification, and saturation of the soil, or rock, or both adjacent to and beneath the pile, (5) quality or type of dynamic test data, (6) foundation settlement, (7) analysis method, and (8) engineering judgment and experience. If the Engineer does not have adequate previous experience with these factors, and with the analysis of

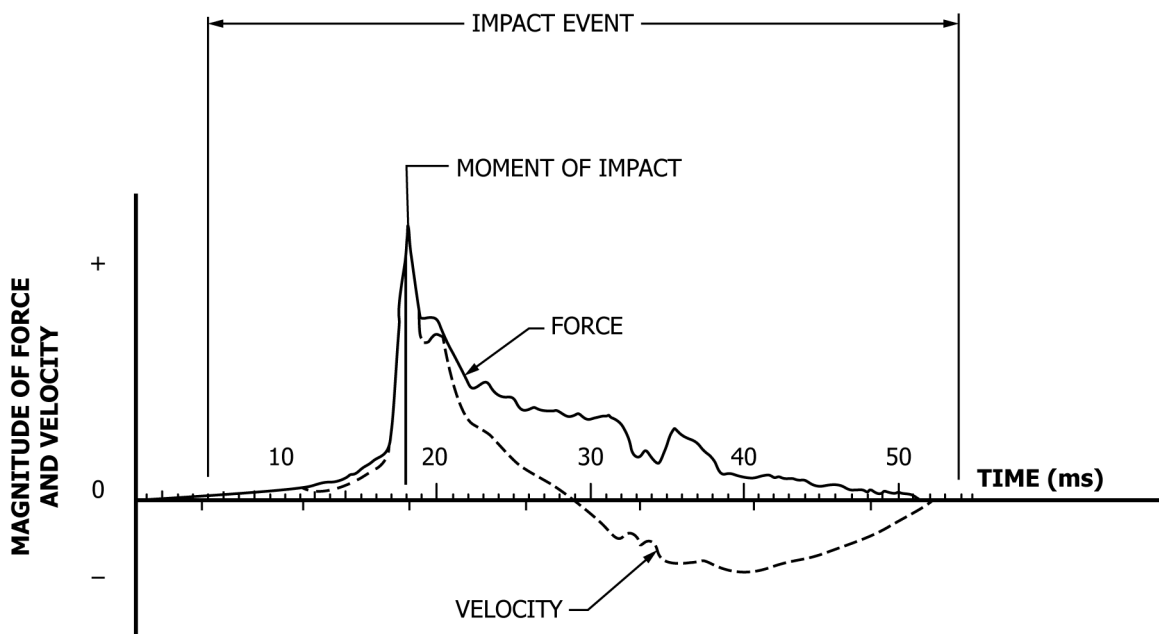

FIG. 1 Typical Force and Velocity Traces Generated by the Apparatus for Obtaining Dynamic Measurements

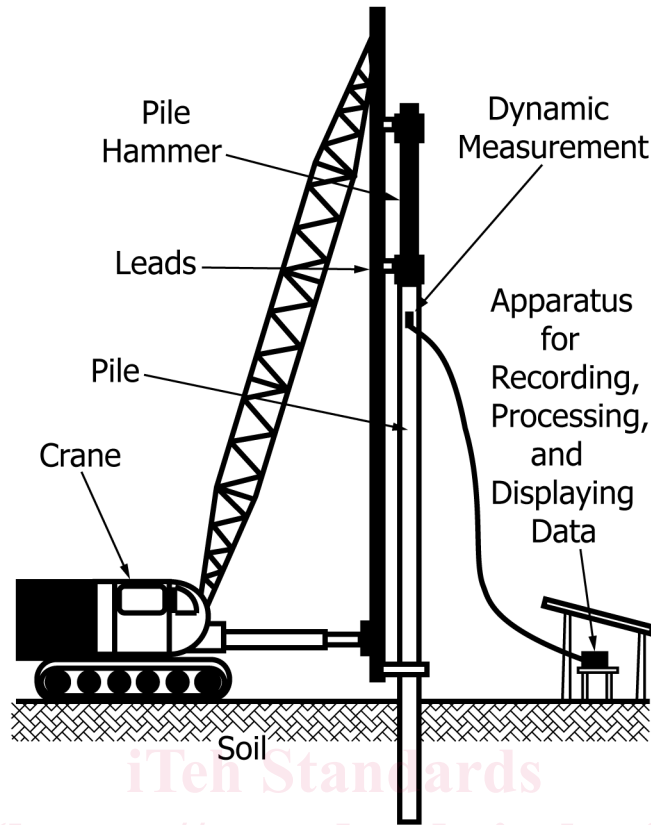

FIG. 2 Typical Arrangement for High-Strain Dynamic Testing of a Deep Foundation

dynamic test data, then a static load test carried out according to Test Method [D1143/D1143M](#) should be used to verify estimates of static capacity and its distribution along the pile length. Test Method [D1143/D1143M](#) provides a direct and more reliable measurement of static capacity:

- (1) pile installation equipment and procedures,
- (2) elapsed time since initial installation,
- (3) pile material properties and dimensions,
- (4) type, density, strength, stratification, and saturation of the soil, or rock, or both adjacent to and beneath the pile,
- (5) quality or type of dynamic test data,
- (6) foundation settlement,
- (7) analysis method, and
- (8) engineering judgment and experience.

If the Engineer does not have adequate previous experience with these factors, and with the analysis of dynamic test data, then a static load test carried out according to Test Method [D1143/D1143M](#) should be used to verify estimates of static capacity and its distribution along the pile length. Test Method [D1143/D1143M](#) provides a direct and more reliable measurement of static capacity.

NOTE 1—The analysis of a dynamic test will under predict the ultimate axial static compression capacity if the pile movement during the impact event is too small. The Engineer should determine how the size and shape of the pile, and the properties of the soil or rock beneath and adjacent to the pile, affect the amount of movement required to fully mobilize the static capacity. A permanent net penetration of as little as 2 mm per impact may indicate that sufficient movement has occurred during the impact event to fully mobilize the capacity. However, high displacement driven piles may require greater movement to avoid under predicting the static capacity, and cast-in-place piles often require a larger cumulative permanent net penetration for a series of test blows to fully mobilize the capacity. Static capacity may also decrease or increase over time after the pile installation, and both static and dynamic tests represent the capacity at the time of the respective test. Correlations between measured ultimate axial static compression capacity and dynamic test estimates generally improve when using dynamic restrike tests that account for soil strength changes with time (see 6.8).

NOTE 2—Although interpretation of the dynamic test analysis may provide an estimate of the pile's tension (uplift) capacity, users of this standard are cautioned to interpret conservatively the side resistance estimated from analysis of a single dynamic measurement location, and to avoid tension capacity estimates altogether for piles with less than 10 m embedded length. (Additional transducers embedded near the pile toe may also help improve tension capacity estimates.) If the Engineer does not have adequate previous experience for the specific site and pile type with the analysis of dynamic test data for tension capacity, then a static load test carried out according to Test Method [D3689](#) should be used to verify tension capacity estimates. Test Method [D3689](#) provides a direct and more reliable measurement of static tension capacity.

NOTE 3—The quality of the result produced by this test method is dependent on the competence of the personnel performing it, and the suitability of the equipment and facilities used. Agencies that meet the criteria of Practice [D3740](#) are generally considered capable of competent and objective testing/sampling/inspection/etc. Users of this test method are cautioned that compliance with Practice [D3740](#) does not in itself assure reliable results.

Reliable results depend on many factors; Practice D3740 provides a means of evaluating some of those factors.

## 5. Apparatus

5.1 *Impact Device*—A high-strain dynamic test measures the pile response to an impact force applied at the pile head and in concentric alignment with its long axis (see Figs. 2 and 3). The device used to apply the impact force should provide sufficient energy to cause pile penetration during the impact event adequate to mobilize the desired capacity, generally producing a maximum impact force of the same order of magnitude, or greater than, the ultimate pile capacity (static plus dynamic). The Engineer may approve a conventional pile driving hammer, drop weight, or similar impact device based on predictive dynamic analysis, experience, or both. The impact shall not result in dynamic stresses that will damage the pile, typically less than the yield strength of the pile material after reduction for potential bending and non-uniform stresses (commonly 90 % of yield for steel and 85 % for concrete). The Engineer may require cushions, variable control of the impact energy (drop height, stroke, fuel settings, hydraulic pressure, etc.), or both to prevent excessive compressive and tensile stress in the pile during all phases of pile testing. In case of a drop mass, the weight of the mass should be at least 1 to 2 % of the desired ultimate test capacity.

5.2 *Dynamic Measurements*—The dynamic measurement apparatus shall include transducers mounted externally on the pile surface, or embedded within a concrete pile, that are capable of independently measuring strain and acceleration versus time during the impact event at a minimum of one specific location along the pile length as described in 5.2.7.

5.2.1 *External Transducers*—For externally mounted transducers, remove any unsound or deleterious material from the pile surface and firmly attach a minimum of two of each of type of transducer at a measurement location that will not penetrate the ground using bolts, screws, glue, solder, welds, or similar attachment.

5.2.2 *Embedded Transducers*—Position the embedded transducers at each measurement location prior to placing the pile concrete, firmly supported by the pile reinforcement or formwork to maintain the transducer location and orientation during the concrete placement. When located near the pile head, one of each type of embedded transducer located at the centroid of the pile cross-section should provide adequate measurement accuracy, which may be checked by proportionality (see 6.9). Embedded transducers installed along the pile length and near the pile toe help define the distribution of the dynamic load within the pile, but usually require data quality checks other than proportionality, such as redundant transducers (see 6.9). Embedded transducers shall provide firm anchorage to the pile concrete to obtain accurate measurements; the anchorage and sensors should not significantly change the pile impedance.

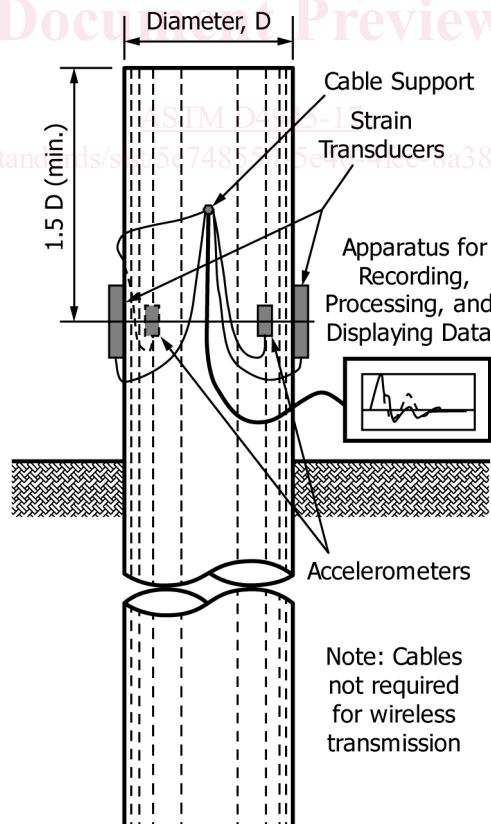

NOTE 1—Strain transducer and accelerometer may be combined into one unit on each side of the deep foundation.

FIG. 3 Schematic Diagram of Apparatus for Dynamic Monitoring of Deep Foundations

5.2.3 *Transducer Accuracy*—The transducers shall be calibrated prior to installation or mounting to an accuracy of 3 % throughout the applicable measurement range. If damaged or functioning improperly, the transducers shall be replaced, repaired and recalibrated, or rejected. The design of transducers, whether mounted or embedded as single units or as a combined unit, shall maintain the accuracy of, and prevent interference between, the individual measurements. In general, avoid mounting or embedding acceleration, velocity, or displacement transducers so that they bear directly on the force or strain transducers, and place all transducers so that they have immediate contact with the pile material.

5.2.4 *Strain Transducers*—*Transducers to Obtain the Force Data:* The strain transducers shall include compensation for temperature effects, and shall have linear output over the full operating range (typically between  $-2000$  and  $+2000$  microstrain plus an additional allowance for possible strain induced by mounting on a rough surface). Attachment points shall be spaced (dimensions S and H in Figs. 4-7) no less than 50 mm and no more than 100 mm apart. When attached to the pile, their natural frequency shall be in excess of 2000 Hz.

5.2.4.1 *Strain Transducers*—The strain transducers shall include compensation for temperature effects, and shall have linear output over the full operating range (typically between  $-2000$  and  $+2000$  microstrain plus an additional allowance for possible strain induced by mounting on a rough surface). Attachment points shall be spaced (dimensions S and H in Figs. 4-7) no less than 50 mm and no more than 100 mm apart. When attached to the pile, their natural frequency shall be in excess of 2000 Hz.

5.2.4.2 *Force Transducers*—As an alternate to strain transducers, axial force measurements can be made by force transducers placed between the pile head and the impact device, or affixed in the pile cross-section, although such transducers may alter the dynamic characteristics of the driving system, the dynamic pile response, or both. Force transducers shall have impedance between 50 and 200 % of the pile impedance. The output signal shall be linearly proportional to the axial force, even under eccentric load application. The connection between the force transducers and the deep foundation shall have the smallest possible mass and least possible cushion necessary to prevent damage.

5.2.5 *Acceleration, Velocity, or Displacement Transducers*—*Transducers to Obtain the Velocity Data:* Velocity data shall be obtained by using the dynamic measurement apparatus to integrate the acceleration signals from accelerometers. The accelerometers shall be directly attached to the pile surface, mounted to the pile with small rigid (solid, nearly cubic shape) metal blocks, or embedded in the pile. Do not use overhanging brackets or plastic mounting blocks that can deform during impact. Accelerometers shall be linear to at least 1000 g and 1000 Hz for concrete piles. For steel piles, it is advisable to use accelerometers that are linear to at least 2000 g and 2000 Hz. For piezoelectric accelerometers using an AC coupled signal path, the resonant

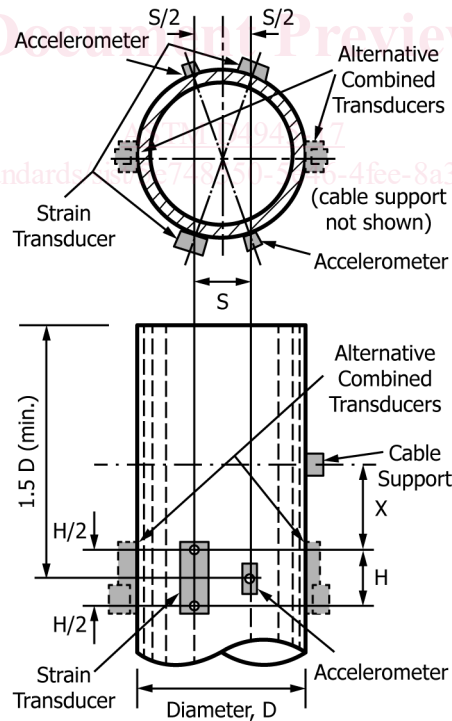

Drill and Tap Holes for Strain Transducers, Accelerometers, and Cable Supports as Shown. Typically use 6 mm Bolt Size.

NOTE 1—Shown as separate transducers or alternative combined transducers.

FIG. 4 Typical Arrangement for Attaching Transducers to Pipe Piles