



Designation: C898/C898M – 09 (Reapproved 2017)

Standard Guide for Use of High Solids Content, Cold Liquid-Applied Elastomeric Waterproofing Membrane with Separate Wearing Course¹

This standard is issued under the fixed designation C898/C898M; the number immediately following the designation indicates the year of original adoption or, in the case of revision, the year of last revision. A number in parentheses indicates the year of last reapproval. A superscript epsilon (ϵ) indicates an editorial change since the last revision or reapproval.

1. Scope

1.1 This guide describes the use of a high solids content, cold liquid-applied elastomeric waterproofing membrane that meets the criteria in Specification C836/C836M, in a waterproofing system subject to hydrostatic pressure for building decks over occupied space where the membrane is covered with a separate protective wearing course.

1.2 The values stated in either SI units or inch-pound units are to be regarded separately as standard. The values stated in each system may not be exact equivalents; therefore, each system shall be used independently of the other. Combining values from the two systems may result in non-conformance with the standard.

1.3 *This standard does not purport to address all of the safety concerns, if any, associated with its use. It is the responsibility of the user of this standard to establish appropriate safety, health, and environmental practices and determine the applicability of regulatory limitations prior to use.*

1.4 *This international standard was developed in accordance with internationally recognized principles on standardization established in the Decision on Principles for the Development of International Standards, Guides and Recommendations issued by the World Trade Organization Technical Barriers to Trade (TBT) Committee.*

2. Referenced Documents

2.1 ASTM Standards:²

- C33/C33M Specification for Concrete Aggregates
- C578 Specification for Rigid, Cellular Polystyrene Thermal Insulation
- C717 Terminology of Building Seals and Sealants

¹ This guide is under the jurisdiction of ASTM Committee D08 on Roofing and Waterproofing and is the direct responsibility of Subcommittee D08.22 on Waterproofing and Dampproofing Systems.

Current edition approved Dec. 1, 2017. Published December 2017. Originally approved in 1978. Last previous edition approved in 2009 as C898/C898M – 09. DOI: 10.1520/C0898_C0898M-09R17.

² For referenced ASTM standards, visit the ASTM website, www.astm.org, or contact ASTM Customer Service at service@astm.org. For *Annual Book of ASTM Standards* volume information, refer to the standard's Document Summary page on the ASTM website.

C836/C836M Specification for High Solids Content, Cold Liquid-Applied Elastomeric Waterproofing Membrane for Use with Separate Wearing Course

C920 Specification for Elastomeric Joint Sealants

C1193 Guide for Use of Joint Sealants

C1299 Guide for Use in Selection of Liquid-Applied Sealants (Withdrawn 2012)³

C1471/C1471M Guide for the Use of High Solids Content Cold Liquid-Applied Elastomeric Waterproofing Membrane on Vertical Surfaces

C1472 Guide for Calculating Movement and Other Effects When Establishing Sealant Joint Width

D1056 Specification for Flexible Cellular Materials—Sponge or Expanded Rubber

D1751 Specification for Preformed Expansion Joint Filler for Concrete Paving and Structural Construction (Nonextruding and Resilient Bituminous Types)

D1752 Specification for Preformed Sponge Rubber Cork and Recycled PVC Expansion Joint Fillers for Concrete Paving and Structural Construction

D5295 Guide for Preparation of Concrete Surfaces for Adhered (Bonded) Membrane Waterproofing Systems

D5957 Guide for Flood Testing Horizontal Waterproofing Installations

D6134 Specification for Vulcanized Rubber Sheets Used in Waterproofing Systems

D6451/D6451M Guide for Application of Asphalt Based Protection Board

D6506 Specification for Asphalt Based Protection Board for Below-Grade Waterproofing

E1907 Guide to Methods of Evaluating Moisture Conditions of Concrete Floors to Receive Resilient Floor Coverings (Withdrawn 2008)³

2.2 American Concrete Institute Standard:

ACI 301 Specifications for Structural Concrete for Buildings⁴

³ The last approved version of this historical standard is referenced on www.astm.org.

⁴ Available from ACI International, P.O. Box 9094, Farmington Hills, MI 4833-9094.

3. Terminology

3.1 For definitions of terms used in the guide, refer to Terminology C717.

3.2 *Definitions of Terms Specific to This Standard:*

3.2.1 *cold-applied*—capable of being applied without heating as contrasted to hot-applied. Cold-applied products are furnished in a liquid state, whereas hot-applied products are furnished as solids that must be heated to liquefy them.

3.2.2 *curing time*—the period between application and the time when the material reaches its design physical properties.

3.2.3 *deflection*—the deviation of a structural element from its original shape or plane due to physical loading, temperature gradients, or rotation of its supports.

3.2.4 *drainage board*—see *prefabricated drainage composite*, the preferred term.

3.2.5 *drainage course*—see *percolation layer* and Fig. 1.

3.2.6 *flashing*—a generic term describing the transitional area between the waterproofing membrane and surfaces above the wearing surface of the building deck; a terminal closure or barrier to prevent ingress of water into the system.

3.2.7 *freeze-thaw cycle*—the freezing and subsequent thawing of a material.

3.2.8 *percolation layer (drainage course)*—a layer of washed gravel or of a manufactured drainage media that allows water to filter through to the drain (see Fig. 1).

3.2.9 *prefabricated drainage composite*—proprietary devices to facilitate drainage, usually a composite laminate of more than one material including filter fabric.

3.2.10 *structural slab*—a horizontal, supporting, cast-in-place, concrete building deck. See Fig. 1.

3.2.11 *troweled finish*—a concrete finish provided by smoothing the surface with power driven or hand trowels or both, after the float finishing operation. A troweled finish is smoother than the floated finish. For specifications, see ACI 301.

3.2.12 *wearing surface*—a surface exposed to traffic, either pedestrian or vehicular, also described as finish wearing surface.

3.2.13 *wet-film thickness*—the thickness of a liquid coating as it is applied.

3.2.14 *wet-film gage*—a gage for measuring the thickness of a wet film.

4. Significance and Use

4.1 Designers and installers of waterproofing systems may consult this guide for a discussion of important elements of the use of cold liquid-applied waterproofing membranes and associated elements of construction. This guide is not intended to serve as a specification for waterproofing installation.

4.2 Long-term performance of waterproofing with a separate wearing course is important because of the substantial difficulty in determining the location of leakage and in removing overlying materials to make repairs.

4.3 Refer to Guide C1471/C1471M for application on below grade walls and vertical surfaces.

5. General

5.1 *Major Components, Subsystems, and Features*—The major components to be considered for a building deck waterproofing system are the structural building deck or substrate to be waterproofed, waterproofing membrane, protection of the membrane, drainage, insulation, and wearing course (see Fig. 1). Additional features to be considered are membrane terminal conditions and expansion joints.

5.2 *Compatibility*—It is essential that all components and contiguous elements be compatible and coordinated to form a totally integrated waterproofing system.

6. Substrate

6.1 *General*—The building deck or substrate referred to in this guide is reinforced cast-in-place structural concrete. Precast concrete slabs pose more technical problems than cast-in-place concrete, and the probability of lasting watertightness is greatly diminished and difficult to achieve because of the multitude of joints which have the capability of movement and must be treated accordingly. Moving joints are critical features of waterproofing systems and are more critical when sealed at the membrane level than at a higher level with the use of integral concrete curbs. Such curbs are impractical with precast concrete slabs and necessitate an even more impractical drain in each slab. Other disadvantages of precast concrete slabs are their inflexibility in achieving contoured slope to drains and the difficulty of coordinating the placement of such drains.

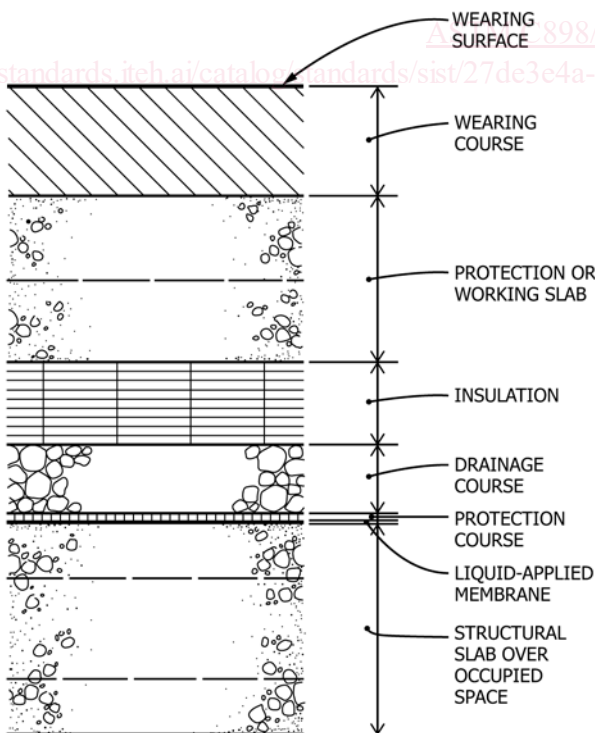

FIG. 1 Basic Components of Cold Liquid-Applied Elastomeric Membrane Waterproofing System with Separate Wearing Course

6.2 *Strength*—The strength of concrete is a factor to be considered with respect to the liquid-applied membrane insofar as it relates to finish, bond strength, and continuing integrity (absence of cracks and other defects that could affect the integrity of the membrane after installation).

6.3 *Density and Moisture Content*—Density of concrete and moisture content when cured are interrelated and can affect adhesion of the membrane to the substrate with an excessively high moisture content, moisture may condense at the membrane and concrete interface and cause membrane delamination. This is particularly so if the top surface is cooler than the concrete below. Lower moisture contents are achieved with the use of hard, dense, stone aggregate. This type of coarse aggregate will generally provide structural concrete with a moisture content from 3 to 5 % when cured. Lightweight aggregate, such as expanded shale, will generally provide lightweight structural concrete with a moisture content from 5 to 20 % when cured. Lightweight insulating concrete made with a weaker expanded aggregate, such as perlite, has a relatively low compressive strength and can contain over 20 % moisture when cured. The concrete used for the substrate should have a minimum density of 1762 kg/m³ [110 lb/ft³] and have a maximum moisture content of 8 % when cured. From this it can be seen that only certain lightweight aggregates can be considered for use and no lightweight insulating aggregates can be used.

6.4 *Admixtures, Additives, and Cement/Concrete Modifiers*—Admixtures, additives, and modifiers serve many functions in mixing, forming, and curing concrete, such as to retard or accelerate the cure rate; reduce the water content required; entrain air; increase strength; create or improve the ability of the concrete to bond to existing, cured concrete; permit thin topping overlayers; and improve workability. Some admixtures and modifiers (particularly polymeric, latex, or other organic chemical based materials) may coat the concrete particles and reduce the ability of the waterproofing membrane to bond to the concrete. The membrane manufacturer should be consulted if the concrete used for the deck will contain any admixtures, additives, or modifiers in order to determine the compatibility of the membrane with the concrete.

6.5 *Underside Liner and Coating*—The underside of the concrete deck should not have an impermeable barrier. A metal liner or coating that forms a vapor barrier on the underside can trap moisture in the concrete and destroy or prevent the adhesive bond of the membrane to the upper surface of the concrete. Uniformly spaced perforations in metal liners may provide a solution to the vapor barrier problem but as yet there are no definitive data on the requirements for the size and spacing of the perforations. It should also be recognized that this method would preclude any painting of the metal liner after the concrete is poured on it.

6.6 *Slope for Drainage*—Drainage at the membrane level is important. When the waterproofing membrane is placed directly on the concrete slab a monolithic concrete substrate slope of a minimum 2 % [$\frac{1}{4}$ in./ft] should be maintained. Slope is best achieved with a monolithic structural slab and not with a separate concrete fill layer. The fill presents the potential of

additional cracks and provides a cleavage plane between the fill and structural slab. This cleavage plane complicates the detection of leakage in the event that water should penetrate the membrane at a crack in the fill and travel along the separation until reaching a crack in the structural slab.

6.7 *Finish*—The structural slab should have a finish that facilitates proper application of the liquid-applied membrane. The surface should be of sufficiently rough texture to provide a mechanical bond for the membrane but not so rough as to preclude achieving continuity of the membrane of the specified thickness across the surface. A typical manufacturer's recommendation is a steel-troweled finish, followed by a fine hair broom.

6.7.1 Concrete surfaces shall be free of laitance, loose aggregate, sharp projections, grease, oil, dirt, curing compounds, or other contaminants that could affect the complete bonding of the liquid-applied membrane to the concrete surface. For preparation and acceptance of concrete surfaces, refer to Guide **D5295**. Application shall not proceed until all protrusions and projections through the structural slab are in place, or sleeves placed through the slab, and provision has been made to secure their watertightness. Concrete surfaces shall be visibly dry and pass any additional dryness tests recommended by the liquid-applied membrane manufacturer prior to application.

6.8 *Curing*—Curing of the structural slab is necessary to provide a sound concrete surface and to obtain the quality of concrete required. The concrete should be cured a minimum of 7 days and aged a minimum of 28 days including curing time, before application of the liquid-applied membrane. Curing is accomplished chemically with moisture and should not be construed as drying.

6.8.1 *Moist Curing*—Moist curing is achieved by keeping the surfaces continuously wet by covering them with burlap saturated with water and kept wet by spraying or hosing. The covering material should be placed to provide complete surface coverage with joints lapped a minimum of 75 mm [3 in.].

6.8.2 *Sheet Curing*—Sheet curing is accomplished with a sheet vapor retarder that reduces the loss of water from the concrete and moistens the surface of concrete by condensation, preventing the surface from drying while curing. Laps of sheets covering the slab should not be less than 50 mm [2 in.] and should be sealed or weighted.

6.8.3 *Chemical Curing*—Liquid or chemical curing compounds should not be used unless approved by the manufacturer of the liquid-applied membrane as the material may interfere with the bond of the membrane to the structural slab.

6.9 *Dryness*—Comply with membrane manufacturer's requirements for substrate dryness. For methods for testing moisture content, refer to Guide **E1907**.

6.10 *Joints*—Joints in a structural concrete slab in this guide are referred to as reinforced joints, nonreinforced joints, and expansion joints.

6.10.1 *Reinforced Joints*—Reinforced joints consist of hair-line cracks, cold joints, construction joints, isolation joints, and control joints held together with steel reinforcing bars or wire fabric. These are considered static joints with little or no

anticipated movement because the slab reinforcement is continuous across the joint.

6.10.2 Nonreinforced Joints—Nonreinforced joints consist of butted construction joints and isolation joints not held together with steel reinforcing bars or wire fabric. These joints are generally considered by the designer of the structural system as nonmoving or static joints. However, they should be considered as capable of having some movement, the magnitude of which is difficult to predict.

6.10.3 Expansion Joints—Expansion joints are designed to accommodate a predetermined amount of movement. Such movement could be due to thermal change, shrinkage, creep, deflection, or other factors and combinations of factors. In the detailing of expansion joints to achieve watertightness, the amount of movement anticipated should be carefully determined using a reasonable factor of safety. The opening size and configuration should then be related to the capability of the joint seal materials to accommodate the anticipated movement. Expansion joints are best located at the high points of a contoured slab to permit water to flow away from the joint.

7. Membrane

7.1 Adherence to Substrate—A liquid-applied waterproofing membrane has the capability of adhering to the structural slab and should be applied to take optimum advantage of this inherent characteristic. The detection of leakage in a building deck waterproofing system that is covered over with a separate wearing course could be a significant problem when the waterproofing membrane is not bonded to the structural slab or when additional layers of material separate the membrane from the structural slab. Water penetrating an unbonded membrane could migrate laterally under the membrane until reaching a crack or defect in the structural slab and then leak through to the space below. Leakage through the slab, therefore, would not necessarily indicate the location of the water entry in the membrane above. That point could be at a considerable distance away, and the costly removal of large areas of the wearing course might be required before it is located.

7.2 Certification, Marking, Shipping, Preservation, and Safety:

7.2.1 Certification—Testing laboratory certification from a laboratory acceptable to the purchaser and containing complete test results shall be made available before delivery of materials to the project site, attesting that the materials conform to the specification requirements. Such certification shall be current with results obtained from tests performed no earlier than one year from the award of contract.

7.2.2 Marking and Shipping—The liquid-applied membrane materials shall be delivered undamaged to the project site in original, sealed containers, clearly identified as to contents, the manufacturer's name, date of manufacture, shelf life, precautions on flammability and toxicity, and shall include instructions as to application procedures.

7.2.3 Preservation—Materials shall be stored and protected from damage and weather in accordance with the manufacturer's instructions and shall be used within the period noted as their shelf life.

7.2.4 Safety—Where hazardous materials are involved, rigid adherence to the special precautions of the manufacturer as modified by local, state, and federal authorities shall be followed.

7.3 Placement Protection—The membrane should be applied under dry, frost-free conditions on the surface as well as throughout the depth of the concrete slab. Excessive moisture in the substrate (see 6.3) or moisture on the surface as from frost or rain will result in a defective membrane with such deficiencies as an improper cure with formation of excessive gas pockets and little or no adhesion to the substrate. Should rain or snow interrupt the application after at least one coat of material has been applied, the instructions of the membrane manufacturer should be followed pertaining to any necessary treatment of the cured, already applied material prior to continuation.

7.3.1 The applicator of the liquid-applied membrane shall inspect the substrate including all penetrations and terminal conditions to determine the suitability for application of the liquid-applied membrane waterproofing. Installation shall not proceed until corrections have been made of any adverse conditions. Any unforeseen but unacceptable conditions shall be brought to the attention of all parties concerned for resolution prior to proceeding.

7.3.2 Waterproofing work shall not commence at ambient temperatures below 5°C [40°F] or when there is any threat of inclement weather (rain or snow) unless precautions are taken to eliminate frost from the substrate or prevent its formation during the application.

7.4 Priming—Primers, when required or recommended by the manufacturer for optimum performance of the liquid-applied membrane, shall be as recommended and supplied by the manufacturer of the liquid-applied membrane.

7.5 Membrane—The liquid-applied membrane shall be in conformance with Specification **C836/C836M**.

7.5.1 The liquid-applied membrane shall be applied directly to the slab in order to obtain 1.5 ± 0.1 mm [60 ± 5 mils] dry film thickness. The 1.5 mm is in addition to any previously applied material. Application shall be made by means of trowel, squeegee, roller, brush, spray apparatus, or other method acceptable to the membrane manufacturer. Wet film thickness shall be checked every 9 m² [100 ft²] by the applicator. Where possible the surface to be coated shall be marked off, in even units, to facilitate proper coverage. At the expansion joints and terminations, the membrane shall be carried over the preformed elastomeric sheet in a uniform 2.5-mm [100-mil] dry thickness to provide a monolithic coating. When work has stopped long enough for the membrane to cure, the first operation of the next application shall be to wipe the previously applied material with a proper solvent to remove the dirt and dust that has accumulated, a condition that could inhibit adhesion of the overlapping membrane coat. Solvent should be as recommended by the membrane manufacturer. Dry-film thickness is relative and depends upon the solids content of the specific membrane selected. To obtain the required wet-film thickness to provide 1.5-mm dry-film thickness, divide the 1.5-mm thickness by the volume solids

content of the coating to obtain the wet-film thickness required. Rule of thumb is 15 L/9 m² [4 gal/100 ft²].

7.6 Terminal Conditions—Four locations where a liquid-applied membrane is normally terminated or interrupted are on walls, at drains, at penetrations, and at expansion joints having relatively large movement. The important consideration at terminal conditions is to prevent water from penetrating into the substrate or behind the membrane at its edge.

7.6.1 Termination on Walls—When the membrane is turned up on a wall, it is preferable to terminate it above the wearing surface to eliminate the possibility of ponded surface water penetrating the wall above the membrane and running down behind it into the building. The minimum safe height of such a termination is dictated by the opportunity for conditions such as ponding and drifted snow presented by the building's geometry and environment. A liquid-applied membrane, because of its inherent adhesive properties, may be terminated flush on the wall without the use of a reglet. However, the use of a reglet in a concrete wall has the advantage of providing greater depth protection at the terminal. The reglet should be a minimum of 6.3 mm [$\frac{1}{4}$ in.] deep and 6.3 mm wide. Termination on a masonry wall will require counterflashing. (See Figs. 2-4.)

7.6.1.1 Where the deck-to-wall intersection is a monolithic concrete pour or of reinforced concrete joint construction, (a) preparation coat(s) totaling 2.5 mm [100 mils] of liquid-applied membrane shall be applied that extends 150 mm [6 in.] onto the horizontal deck and up the vertical wall to the termination height (see Fig. 5). At the applicator's option, a cant strip formed with the liquid-applied membrane having a 45° beveled face of 13 mm [$\frac{1}{2}$ in.] may be applied (see Fig. 5).

7.6.2 Termination at Drains—Drains should be designed with a wide flange or base as an integral part. The drain base should be set flush with the structural slab. The wide flange provides a termination point for the liquid-applied membrane without endangering the function of the membrane or the drain.

7.6.2.1 Drain flanges shall have been set flush with the surface of the structural slab. The liquid-applied membrane shall be applied 1.5 mm [60 mils] thick over the drain flange or collar with care not to plug any drainage or weep holes. The doubled membrane shall extend 150 mm [6 in.] beyond the flange onto the structural slab (see Fig. 6).

7.6.3 Termination at Penetrations—Penetrations or protrusions through the slab by such items as conduits and service pipes create critical problems and should be avoided wherever possible. For protection at such critical locations, pipe sleeves should be cast into the structural slab against which the membrane can be terminated. Core drilling to provide openings for penetrations is not recommended.

7.6.3.1 Protrusions or projections through the structural slab, such as vents and service pipes, shall be treated before application of the liquid-applied membrane. An application of 2.5 mm [100 mils] of liquid-applied membrane shall be made over a sealant joint and up the pipe sleeve and extended 150 mm [6 in.] onto the structural slab (see Fig. 7)

7.7 Treatment at Joints—Joints in the structural slab should be treated as follows, depending upon whether they are reinforced joints, nonreinforced joints or expansion joints:

7.7.1 All preparation of surfaces, cracks or joints, and termination points, including priming, if required, shall be completed before the application of the monolithic liquid-applied membrane. If required, priming shall be done not more than 24 h before the membrane is placed. Reinforced joints or cracks in the structural slab may be pretreated by cleaning and coating with a 1.5-mm [60-mil] dry film application of liquid-applied membrane extending 76 mm [3 in.] from each side of the joint or crack (see Fig. 8).

7.7.2 Treatment at Reinforced Joints—Fig. 8 indicates one recommended treatment of reinforced concrete joints in the structural slab. The designer should realize that the elongation capacity of this type of detail is quite limited and implicitly relies on the membrane's crack-bridging ability to withstand the strains imposed by the opening of cracks and reinforced joints. An alternative approach that may be considered is to prevent the membrane from adhering to the substrate for a finite width centered on the joint or crack by means of a properly designed compatible bond-breaker tape.

7.7.3 Treatment at Nonreinforced Joints—Nonreinforced joints that are in reality nonmoving could be treated in the same manner as reinforced joints. However, since the joints are not held together with reinforcing steel, some movement, however slight, should be anticipated and provided for, since the liquid-applied membrane has limited ability to take movement. Nonreinforced joints could open due to such factors as shrinkage, creep, and thermal contraction. Fig. 9 shows a nonreinforced butted joint that is capable of expanding 3.2 mm [$\frac{1}{8}$ in.], the minimum that should be provided for when using a sealant capable of $\pm 25\%$ movement. The minimum sealant width should be correspondingly wider with a sealant having lesser movement capability. If the designer of the structural system feels that greater movement than 3.2 mm [$\frac{1}{8}$ in.] could occur in such joints, they should be treated as expansion joints.

7.7.3.1 Sealant—Sealant for use in nonreinforced butted joints in a structural concrete slab shall be an elastomeric sealant compatible with the liquid-applied membrane conforming to Specification C920. The compatibility of the liquid-applied membrane and the sealant shall be determined by the manufacturer of the liquid-applied membrane.

7.7.3.2 Sealant Primer—A primer when required or recommended by the manufacturer of the sealant for optimum

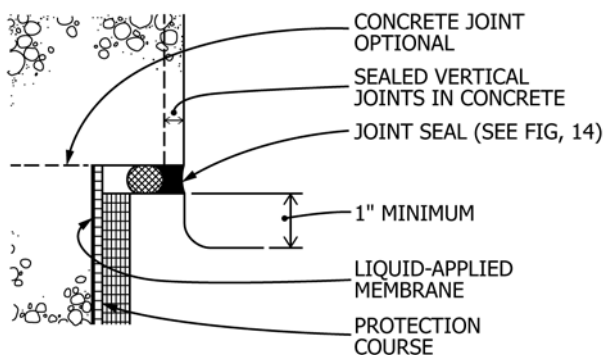

FIG. 2 Terminal Condition Above Finish Grade on Concrete Wall (see 7.6.1)

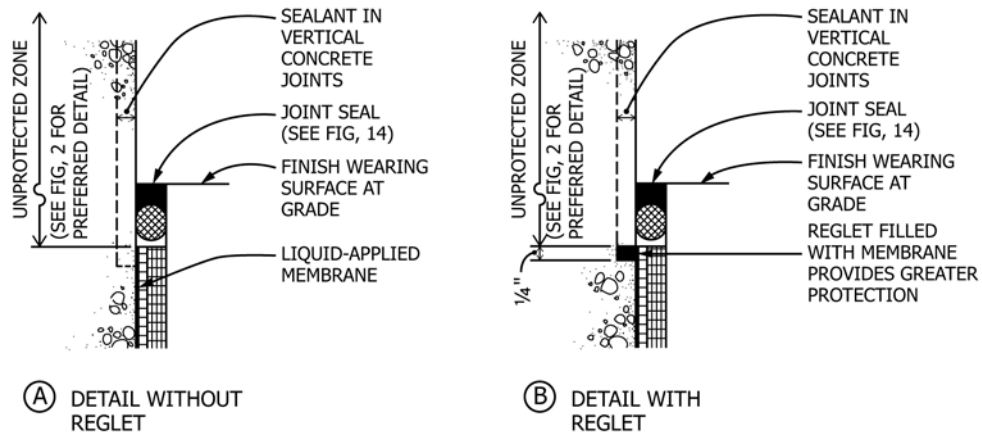

FIG. 3 Terminal Conditions on Concrete Wall Below Finish Wearing Surface at Grade (see 7.6.1)

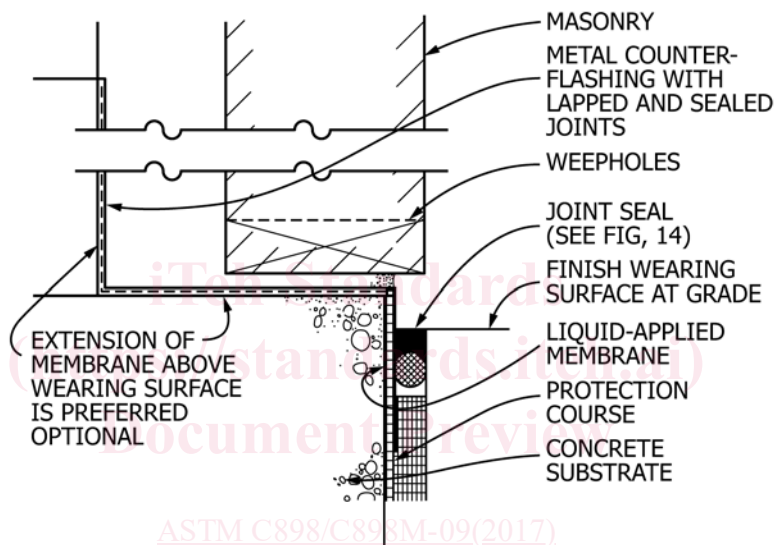

FIG. 4 Terminal Condition with Masonry Above Finish Wearing Surface at Grade (see 7.6.1) c898m-092017

adhesion of the sealant to the joint interface shall be as recommended by or supplied by the sealant manufacturer and shall be compatible with the liquid-applied membrane. The compatibility of the sealant primer with the liquid-applied membrane shall be determined by the manufacturer of the liquid-applied membrane

7.7.3.3 *Joint Filler Type A*—Joint filler shall be a closed-cell, polyethylene or premolded cellular elastomeric rod with integral bond breaker of a diameter 25 % larger than the joint width when compressed into the joint and, if greater, shall be in accordance with the manufacturer’s recommendations

7.7.3.4 *Joint Filler Type B*—Joint filler shall be a closed-cell, polyethylene strip of the depth indicated and 25 % wider than the joint at the time of installation

7.7.3.5 *Joint Filler Type C*—Joint filler shall be a premolded strip in conformance with Specifications D1751 or D1752.

7.7.3.6 *Bond Breaker*—Bond breakers shall be compatible types as recommended by the manufacturer of the liquid-applied membrane. The bond breaker shall not interfere with the curing process or other performance properties of the liquid-applied membrane.

7.7.4 *Treatment at Expansion Joints*—There are basically two concepts that could be considered in the detailing of expansion joints at the membrane level of membrane waterproofing systems. These are the *positive seal concept* directly at the membrane level and the *water shed concept* with the seal at a higher level than the membrane. Where additional safeguards are desired, a drainage gutter under the joint could be considered (see Fig. 10). Note that flexible support of the membrane is required in each case. Expansion joint details should also be considered and used in accordance with their movement capability.

7.7.4.1 *Positive Seal Concept*—The positive seal concept entails a greater risk than the water shed concept since it relies fully on positive seal joinery of materials at the membrane level, where the membrane is most vulnerable to water penetration. The materials used, and their joinery, must be carefully engineered by the manufacturer of the liquid-applied waterproofing system, and subsequent field installation requires the best of workmanship with no margin for error for potential success. Since the precision required is not always attainable, this concept is best avoided.