

**This PDF file has been prepared by TC 57 experts and is made available to assist the users of the IEC 61850-7 series.**

Please note:

- There was no IEC vote on these files, and IEC Central Office does therefore not take any responsibility as to their contents.
- Adobe Acrobat® 6.0 is required to navigate through this file.

Any comments on these files are to be communicated to the following address:

Karlheinz Schwarz  
([schwarz@scc-online.de](mailto:schwarz@scc-online.de))

iteh Standards  
(<https://standards.iteh.ai>)  
Document Preview

[IEC 61850-7-4:2003](#)

<https://standards.iteh.ai/catalog/standards/iec/34afb6d5-3c7b-481c-9e57-646c27808884/iec-61850-7-4-2003>

# IEC 61850 - Communication networks and systems in substations

## Informative tutorial on the object models

**NOTE 1** These pdf files (html pages) are intended to provide a hypertext version of an excerpt of the main concepts and definitions of Parts IEC 61850-7-4, IEC 61850-7-3, and IEC 61850-7-2.

**NOTE 2** The content of these files is informative only. They do in no way replace the normative definitions contained in the above referenced documents.

There are the following pages to browse and study the object models:

1. [Modeling approach of logical nodes \(one page - pdf\)](#)
2. [IEC 61850-7-2 Overview of ACSI models](#)
3. [Logical nodes of 61850-7-4](#)
4. [Common data classes](#) in a single window

The xml files containing the models are (**not available in the pdf format**):

- Logical Nodes from IEC 61850-7-4:2003 LN.xml
- DATA Semantics from IEC 61850-7-4:2003 Data-Sematic.xml
- DATA-Attributes from IEC 61850-7-3:2003 CDC.xml
- DATA-Attribute Semantics from IEC 61850-7-3:2003 DA-Semantic.xml
- Common Data Attributes from IEC 61850-7-3:2003 CDA.xml

<https://standards.iteh.ai/catalog/standards/iec/34afb6d5-3c7b-481c-9e57-646c27808884/iec-61850-7-4-2003>

These xml files can be used to produce any other presentation. They should not be used as normative xml documents.

## Parts of the standard

- IEC 61850-1, Part 1: Introduction and overview
- IEC 61850-2, Part 2: Glossary
- IEC 61850-3, Part 3: General requirements
- IEC 61850-4, Part 4: System and project management
- IEC 61850-5, Part 5: Communication requirements for functions and devices models
- IEC 61850-6, Part 6: Configuration description language for communication in electrical substations related to IEDs
- IEC 61850-7-1, Part 7-1: Basic communication structure for substation and feeder equipment - Principles and models
- IEC 61850-7-2, Part 7-2: Basic communication structure for substation and feeder equipment - Abstract communication service interface (ACSI)
- IEC 61850-7-3, Part 7-3: Basic communication structure for substation and feeder equipment - Common data classes
- IEC 61850-7-4, Part 7-4: Basic communication structure for substation and feeder equipment - Compatible logical node classes and data classes
- IEC 61850-8-1, Part 8-1: Specific communication service mapping (SCSM) - Mappings to MMS

(ISO/IEC 9506-1 and ISO/IEC 9506-2) and to ISO/IEC 8802-3

- IEC 61850-9-1, Part 9-1: Specific communication service mapping (SCSM) - Sampled values over serial unidirectional multidrop point to point link
- IEC 61850-9-2, Part 9-2: Specific communication service mapping (SCSM) - Sampled values over ISO/IEC 8802-3
- IEC 61850-10, Part 10: Conformance testing

The web pages and the corresponding xml files have been created by

**Karlheinz Schwarz, SCC.** ([schwarz@scc-online.de](mailto:schwarz@scc-online.de))

SCC does not take any responsibility as to the content of the files contained in the ZIP file "IEC61850\_HTML.zip" (html, xml and jpg) or the "browsable" pdf file and linked on this page respectively.

**Karlheinz Schwarz, based in Karlsruhe, Germany,** is a consultant for the power systems control industry. He is involved in several Working Groups within IEC TC 57, TC 65, and TC 88. He is a well-known authority on the standardization and application of advanced information and communication technologies.

© IEC 2004

Version 1.1 2004-03-22

**iTeh Standards**  
**(<https://standards.iteh.ai>)**  
**Document Preview**

[IEC 61850-7-4:2003](#)

<https://standards.iteh.ai/catalog/standards/iec/34afb6d5-3c7b-481c-9e57-646c27808884/iec-61850-7-4-2003>

# What is a Logical Node?

By Karlheinz Schwarz, SCC, [schwarz@scc-online.de](mailto:schwarz@scc-online.de)

## Motivation

The standard IEC 61850 „Communication networks and systems in substations” and the coming standard IEC 61400-25 „Communications for monitoring and control of wind power plants” use the concept of **Logical Nodes (LN)** as a key element to define the information of a device to be communicated. This paper introduces the concept of LNs.

## Modeling concept

A key issue are the LNs **representing functions or equipment** used in power systems. Each LN provides a list of **well organized and named information**. The LN “XCBR5” represents the “circuit breaker” number 5 with the data “Pos” (Position) and “Mode”. Services defined in IEC 61850-7-2 allow the exchange of this information.

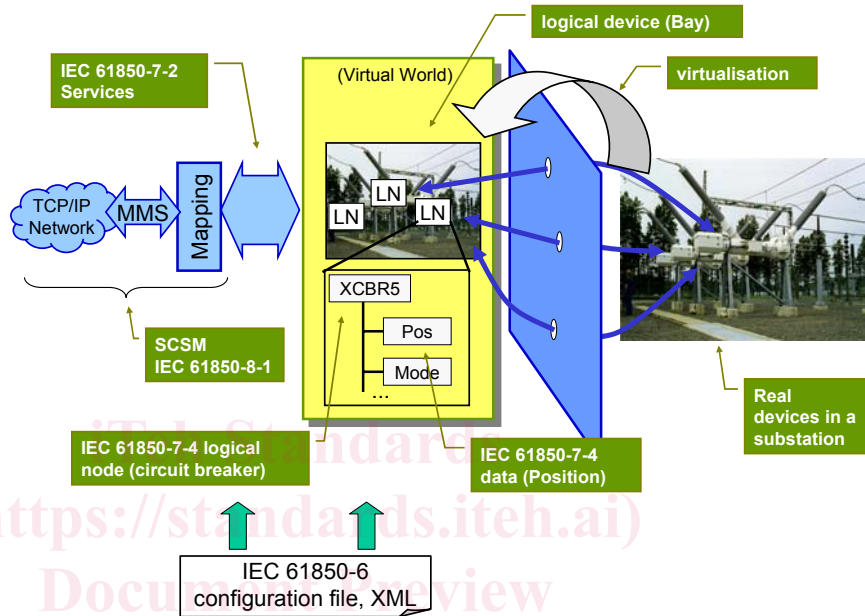

The substation configuration language in part 6 supports the engineering process.

## Example LN “MMXU”

The measurement LN “MMXU” represents power, voltages, currents, and impedances in a three-phase system. The values can be communicated by various services

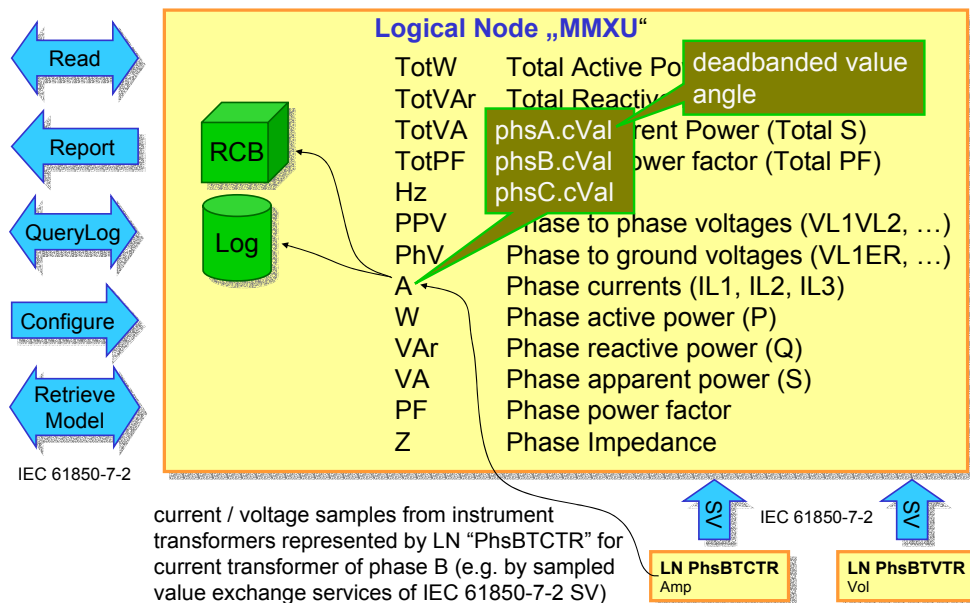

The “MMXU” LN offers hundreds of values: measured (process) values, configuration values, description, and substitution values. These values can be communicated by various services like read (polling), notification (publish/subscribe), logging and query.

**IEC 61850**  
models substation equipment and functions (focus is on protection)

**IEC 61400-25**  
models components of wind power plants like rotor, generator, gear box, nacelle etc. (focus is on SCADA)

**IEC 61850-7-4**  
defines some  
90 LNs  
500 Data  
100 Attributes  
10 Service models

**IEC 61400-25**  
adds some  
10 LNs  
200 Data  
100 Attributes

# ACSI overview and basic concepts

## General

### The models of the ACSI provide

- the specification of a basic model for the definition of the substation-specific information models contained in IEC 61850-7-3 (common DATA classes) and IEC 61850-7-4 (compatible LOGICAL-NODE classes and compatible DATA classes) and
- the specification of information exchange service models.

The information models and information exchange services are interwoven. From a descriptive point of view, the two aspects are separated to some degree (see the excerpt shown in Figure 1). The common models (for example, LOGICAL-NODE and DATA classes including their services) are applied in IEC 61850-7-3 and IEC 61850-7-4 to define many specialized information models - the substation automation models.

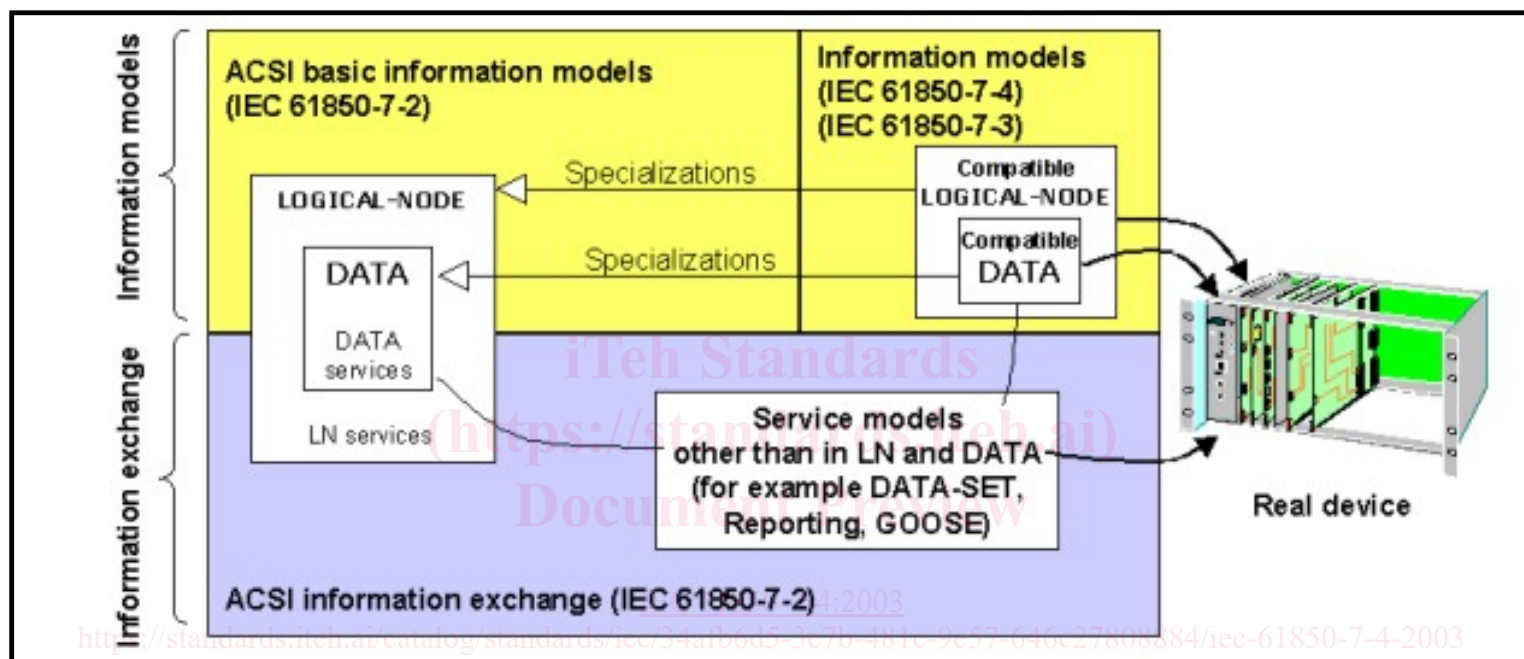

Figure 1 - Excerpt of conceptual model

Other service models required for substation automation systems (for example, DATA-SET and reporting provide specific information exchange services) are also defined in this part of the standard; these models are linked to LOGICAL-NODES and DATA. The information exchange services are completely defined in the ACSI. The information models defined in IEC 61850-7-4 reference the services defined in the various models of the ACSI.

## Overview of basic information models

The conceptual models to build the domain-specific information models are:

- SERVER - represents the external visible behaviour of a device. All other ACSI models are part of the server.  
NOTE 1 A server has two roles: to communicate with a client (most service models in IEC 61850 provide communication with client devices) and to send information to peer devices (for example, for sampled values).
- LOGICAL-DEVICE (LD) - contains the information produced and consumed by a group of domain-specific application functions; functions are defined as LOGICAL-NODES.
- LOGICAL-NODE (LN) - contains the information produced and consumed by a domain-specific application function, for example, overvoltage protection or circuit-breaker.
- DATA - provide means to specify typed information, for example, position of a switch with quality information and timestamp, contained in LOGICAL-NODES.

Each of these information models is defined as a class. The classes comprise attributes and services. The conceptual class diagram of the ACSI is depicted in Figure 2.

*NOTE 2 The classes are major building blocks that provide the framework for substation automation device models. Additional details on the modelling and relations between IEC 61850-7-4, IEC 61850-7-3, and this part of IEC 61850 can be found in IEC 61850-7-1.*

**Click on boxes to get the definitions!**

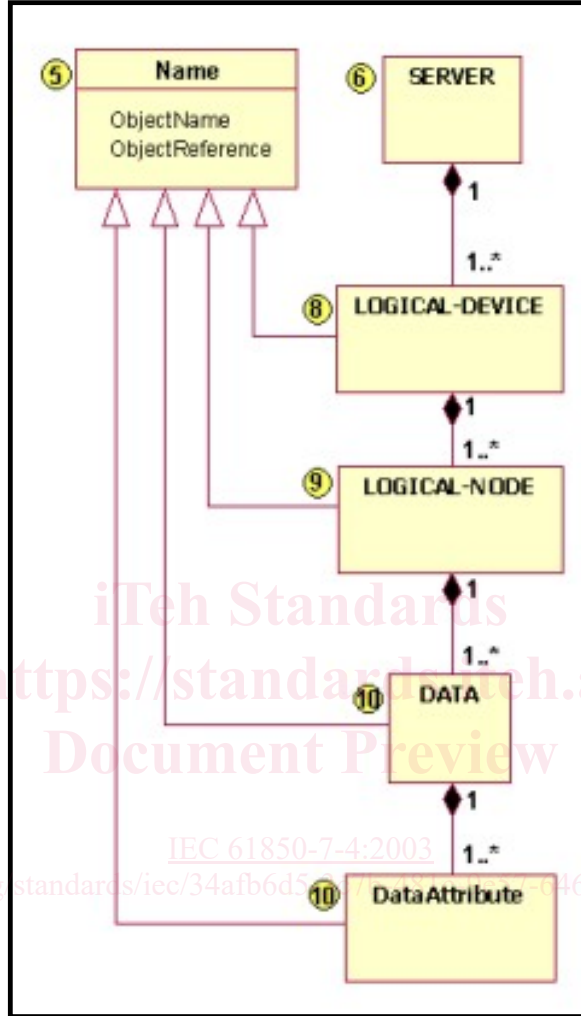

**Figure 2 - Basic conceptual class model of the ACSI**

**Click on boxes to get the definitions!**

*NOTE 3 The numbers in the circles indicate the respective clauses in this part of IEC 61850.*

The Name class is inherited by the classes **LOGICAL-DEVICE**, **LOGICAL-NODE**, **DATA**, and **DataAttribute**.

*EXAMPLE In an implementation the logical device, logical node, data, and data attribute have each an object name (instance name) which is a unique name among classes of the same container to which they belong. In addition, each of the four has an ObjectReference (path name) which is a concatenation of all object names from each container. The four object names (one per column) can be concatenated.*

	Logical device	Logical node	Data	Data attribute
<b>Object name</b>	"Atlanta_HV5"	"XCBR1"	"Pos"	"stVal"

Description	High-voltage station 5	Circuit-breaker 1	Position	Status value
-------------	------------------------	-------------------	----------	--------------

## Overview of the other service models

In addition to the models listed above, the ACSI comprises the following models that provide services operating on data, data attributes, and data sets.

- [DATA-SET](#) - permits the grouping of data and data attributes. Used for direct access and for reporting and logging.
- Substitution - supports replacement of a process value by another value.
- [SETTING-GROUP-CONTROL-BLOCK](#) - defines how to switch from one set of setting values to another one and how to edit setting groups.
- [REPORT-CONTROL-BLOCK](#) and LOG-CONTROL-BLOCK - describe the conditions for generating reports and logs based on parameters set by the client. Reports may be triggered by changes of process data values (for example, state change or dead band) or by quality changes. Logs can be queried for later retrieval. Reports may be sent immediately or deferred. Reports provide change-of-state and sequence-of-events information exchange.
- [control blocks for generic substation event](#) (GSE) - supports a fast and reliable system-wide distribution of input and output data values; peer-to-peer exchange of IED binary status information, for example, a trip signal.
- control blocks for transmission of sampled values - fast and cyclic transfer of samples, for example, of instrument transformers.
- control - describes the services to control, for example, devices.
- time and time synchronization - provides the time base for the device and system.
- file transfer - defines the exchange of large data blocks such as programs.

An overview of the conceptual service model of the ACSI is shown in Figure 3.

**Click on boxes to get the definitions!**

[IEC 61850-7-4:2003](#)

<https://standards.iteh.ai/catalog/standards/iec/34afb6d5-3c7b-481c-9e57-646c27808884/iec-61850-7-4-2003>

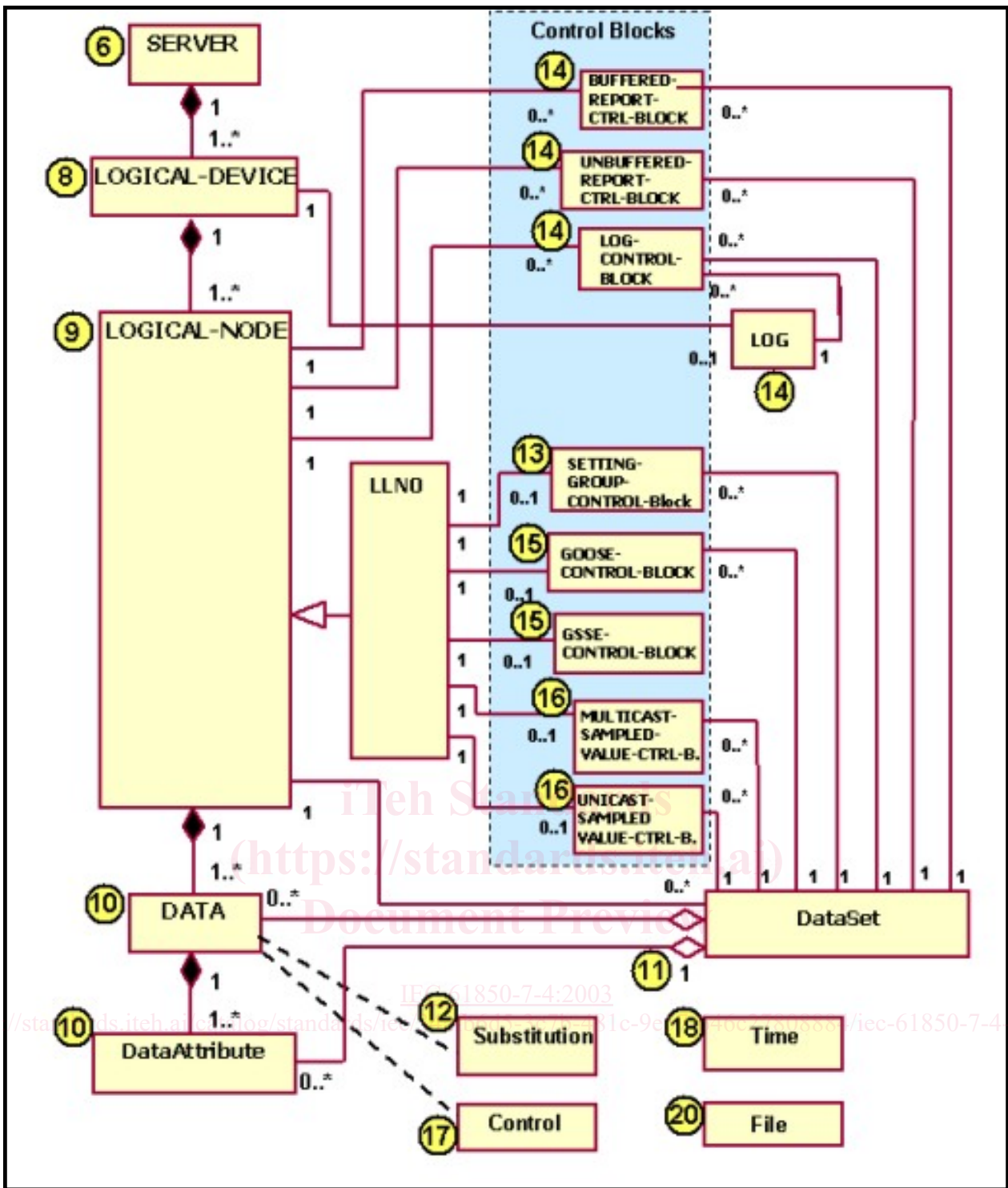

**Figure 3 - Conceptual service model of the ACSI**

**Click on boxes to get the definitions!**

*NOTE 1* The numbers in the circles indicate the respective clauses in this part of IEC 61850.

*NOTE 2* The class diagrams are conceptual. Details are defined in the respective clauses. Comprehensive diagrams are contained in IEC 61850-7-1. The DATA class may be defined recursively. The operations for substitution and control are restricted to the lowest level in the DATA class. The DataAttributes may be defined recursively as well.

The logical node is one of the major building blocks that has associations to most of the other information exchange models, for example, report control, log control, and setting control.

Any other information exchange service model, for example, report control, log control, and setting control shall inherit the ObjectName and ObjectReference as depicted in Figure 2.

*NOTE 3* The class models and services are defined using an object-oriented approach allowing for the mapping



## Overview of ACSI services

The complete list of ACSI classes and their services is shown in Table 1.

**Table 1 - ACSI classes**

<p><b><u>SERVER model</u></b> (Clause 6)</p> <p>GetServerDirectory</p> <p><b>ASSOCIATION model</b> (Clause 7)</p> <p>Associate Abort Release</p> <p><b><u>LOGICAL-DEVICE model</u></b> (Clause 8)</p> <p>GetLogicalDeviceDirectory</p> <p><b><u>LOGICAL-NODE model</u></b> (Clause 9)</p> <p>GetLogicalNodeDirectory GetAllDataValues</p> <p><b><u>DATA model</u></b> (Clause 10)</p> <p>GetDataValues SetDataValues GetDataDirectory GetDataDefinition</p> <p><b><u>DATA-SET model</u></b> (Clause 11)</p> <p>GetDataSetValues SetDataSetValues CreateDataSet DeleteDataSet GetDataSetDirectory</p> <p><b>Substitution model</b> (Clause 12)</p> <p>SetDataValues GetDataValues</p> <p><b><u>SETTING-GROUP-CONTROL-BLOCK model</u></b> (Clause 13)</p> <p>SelectActiveSG SelectEditSG SetSGValues ConfirmEditSGValues GetSGValues GetSGCBValues</p> <p><b>REPORT-CONTROL-BLOCK and LOG-CONTROL-BLOCK model</b> (Clause 14)</p> <p><b><u>BUFFERED-REPORT-CONTROL-BLOCK:</u></b></p> <p>Report GetBRCBValues SetBRCBValues</p> <p><b><u>UNBUFFERED-REPORT-CONTROL-BLOCK:</u></b></p> <p>Report</p>	<p><b><u>LOG-CONTROL-BLOCK model:</u></b></p> <p>GetLCBValues SetLCBValues QueryLogByTime QueryLogAfter GetLogStatusValues</p> <p><b>Generic substation event model —</b> GSE (Clause 15)</p> <p>GOOSE SendGOOSEMessage GetGoReference GetGOOSEElementNumber GetGoCBValues SetGoCBValues GSSE SendGSSEMessage GetGsReference GetGSSEDataOffset GetGsCBValues SetGsCBValues</p> <p><b>Transmission of sampled values model</b> (Clause 16)</p> <p><b><u>MULTICAST-SAMPLE-VALUE-CONTROL-BLOCK:</u></b></p> <p>SendMSVMessage GetMSVCBValues SetMSVCBValues</p> <p><b><u>UNICAST-SAMPLE-VALUE-CONTROL-BLOCK:</u></b></p> <p>SendUSVMessage GetUSVCBValues SetUSVCBValues</p> <p><b>Control model</b> (Clause 17)</p> <p>Select SelectWithValue Cancel Operate CommandTermination TimeActivatedOperate</p> <p><b>Time and time synchronization</b> (Clause 18)</p> <p>TimeSynchronization</p> <p><b>FILE transfer model</b> (Clause 20)</p> <p>GetFile SetFile DeleteFile GetFileAttributeValues</p>
---	--

## 5 ObjectName

The ObjectName shall specify a unique instance name among instances of a class owned by the same parent class with a type as specified in Table 3 - ObjectName type

ObjectName type			
Attribute name	Attribute type	Value/value range/explanation	Used by
ObjectName	VISIBLE STRING32	Name of an instance of a class of a single hierarchy level	IEC 61850-7-4 IEC 61850-7-3 IEC 61850-7-2
NOTE Clause 19 specifies constraints on the use of the type ObjectName.			

## 5 ObjectReference

Instances of classes in the hierarchical information model (ACSI class hierarchy of logical device, logical node, data, data attributes) shall be constructed by the concatenation of all instance names comprising the whole path-name of an instance of a class that identifies the instance uniquely. The type of the ObjectReference shall be as specified in Table 4.

Table 4 - ObjectReference type

ObjectReference type			
Attribute name	Attribute type	Value/value range/explanation	Used by
ObjectReference	VISIBLE STRING255	ObjectReference comprises the whole path-name of an instance of a class that identifies the instance uniquely	IEC 61850-7-2

The ObjectReference syntax shall be:

LDName/LNName[.Name[. ...]]

The "/" shall separate the instance name of a logical device (LDName) from the name of an instance of a logical node (LNName). The "." shall separate the further names in the hierarchy. The "[" shall indicate an option. The inner square bracket "[. ...]" shall indicate further names of recursively nested definitions.

*NOTE 1 In any case where the context of the text provides sufficient information that an instance of a class is meant, the term "instance of" is not used.*

## 6 Server

The class **SERVER** shall represent the externally visible behaviour of a device. The SERVER shall be a composition as defined in Table 11.

NOTE 1 For simple devices the server may comprise just one logical device with the GOOSE control model with no other service.

**Table 11 - SERVER class definition**

SERVER class		
Attribute name	Attribute type	Value/value range/explanation
ServiceAccessPoint [1..n]	(*)	(*) Type is SCSM specific
LogicalDevice [1..n]	LOGICAL-DEVICE	
File [0..n]	FILE	
TPAppAssociation [0..n]	TWO-PARTY-APPLICATION-ASSOCIATION	
MCAAppAssociation [0..n]	MULTICAST-APPLICATION-ASSOCIATION	
<b>Services</b> GetServerDirectory		

NOTE 2 The server's relationship to the underlying communication system and the concrete implementation depend on the SCSM (specific communication service mapping, see IEC 61850-8-x and IEC 61850-9-x) used. Network management (as part of an SCSM), device management, and system management are outside the scope of IEC 61850-7-2.

## 8 Logical Device

The LOGICAL-DEVICE (LD) shall be a composition of LOGICAL-NODE as defined in Table 14.

NOTE- A LOGICAL-DEVICE can be used simply as a container of a group of LOGICAL-NODEs or as a device that functions as a gateway or proxy. Details on the use of LOGICAL-DEVICE can be found in IEC 61850-7-1.

**Table 14 - LOGICAL-DEVICE (LD) class definition**

LOGICAL-DEVICE class

Attribute name	Attribute type	Value/value range/explanation
LDName	ObjectName	Instance name of an instance of LOGICAL-DEVICE
LDRef	ObjectReference	Path-name of an instance of LOGICAL-DEVICE
LogicalNode [3..n]	LOGICAL-NODE	IEC 61850-7-4 specifies specialized classes of LOGICAL-NODE
<b>Services</b>		
GetLogicalDeviceDirectory		

## 9 LOGICAL NODE

The LOGICAL-NODE shall be a composition of DATA, DATA-SET, BRCB, URCB, LCB, LOG, SGCB, GoCB, GsCB, MSVCB, and USVCB as defined in Table 15.

**Table 15 - LOGICAL-NODE (LN) class definition**

LOGICAL-NODE class		
Attribute name	Attribute type	Explanation
LNName	ObjectName	Instance name of an instance of LOGICAL-NODE
LNRef	ObjectReference	Path-name of an instance of LOGICAL-NODE
Data [1..n]	DATA	
DataSet [0..n]	DATA-SET	
BufferedReportControlBlock [0..n]	BRCB	
UnbufferedReportControlBlock [0..n]	URCB	
LogControlBlock [0..n]	LCB	
<b>IF compatible LN class defined in IEC 61850-7-4 equals LLN0</b>		
SettingGroupControlBlock [0..1]	SGCB	
Log [0..1]	LOG	

GOOSEControlBlock [0..n]	GoCB	
GSSEControlBlock [0..n]	GsCB	
MulticastSampledValueControlBlock [0..n]	MSVCB	
UnicastSampledValueControlBlock [0..n]	USVCB	
<b>Services</b>		
GetLogicalNodeDirectory GetAllDataValues		
<i>NOTE 1 IEC 61850-7-4 defines specialized logical node classes - the compatible logical node classes, for example, XCBR representing circuit-breakers.</i>		

The definition of LOGICAL-NODEs for the substation-application domain is refined by the definition of specific DATA in IEC 61850-7-4. The definitions in IEC 61850-7-4 (and IEC 61850-7-3 for the common DATA classes) shall be taken into account to get the comprehensive definition of substation-domain-specific LOGICAL-NODEs.

*NOTE 2 IEC 61850-7-4 defines further attributes for LOGICAL-NODEs; for example,, the mode (behaviour: ON, BLOCKED, TEST, etc.) of the substation-specific LOGICAL-NODE is defined in IEC 61850-7-4. The state model of a LOGICAL-NODE is modelled as a specific DATA (named Mod).*

## 10 Data

<https://standards.iteh.ai/catalog/standards/iec/34afb6d5-3c7b-481c-9e57-646c27808884/iec-61850-7-4-2003>

The DATA shall have the structure defined in Table 16.

**Table 16 - DATA class definition**

DATA class		
Attribute name	Attribute type	Value/value range/explanation
DataName	ObjectName	Instance name of an instance of DATA, for example, PhV (1st level), phsA (2nd level)
DataRef	ObjectReference	Path-name of an instance of DATA, for example, MMXU1.PhV or for example, MMXU1.PhV.PhsA
Presence	BOOLEAN	Indicates mandatory/optional

DataAttribute [0..n] DataAttributeTypeFunctionalConstraint TrgOp [0..n]	DAType FC TriggerConditions	For example, Vector class of IEC 61850-7-3 for example, MX for example, dchg
Specializations of DATA		
CompositeCDC [0..n]	DATA	For example, WYE class of IEC 61850-7-3
SimpleCDC [0..n]	COMMON-DATA	For example, CMV class of IEC 61850-7-3
<b>Services</b>		
GetDataValues SetDataValues GetDataDirectory GetDataDefinition		

An instance of a DATA class may contain zero or more instances of a CompositeCDC, SimpleCDC or a DataAttribute. However, they cannot all be absent, so at least one of these elements shall be present.

*NOTE 5 The structure of a DATA class is recursive since a CompositeCDC is also of type DATA class. The level of recursion may be restricted by a SCSM, so the number of levels of recursion of CompositeCDCs is normally no greater than 1.*

*NOTE 6 DATA or part of a DATA may be referenced in a DATA-SET. The persistent existence of DATA is expected as long as they are referenced as members of a DATA-SET. A system has to take special measures to ensure their existence.*

iTeh Standards  
Document Preview

[IEC 61850-7-4:2003](https://standards.iteh.ai/catalog/standards/iec/34afb6d5-3c7b-481c-9e57-646c27808884/iec-61850-7-4-2003)

## 10 Data Attribute Type

The DAType shall be as defined in Table 17.

**Table 17 - DAType definition**

DAType		
Attribute name	Attribute type	Value/value range/explanation
DATName	ObjectName	Instance name of an instance of DAType, for example, cVal (1stlevel), mag (2nd level), f (3rd level)
DATRef	ObjectReference	Path-name of an instance of DAType for example, MMXU1.PhV.phsA.cVal for example, MMXU1.PhV.phsA.cVal.mag or for example, MMXU1.PhV.phsA.cVal.mag.f
Presence	BOOLEAN	Indicates mandatory/optional