



Designation: G 77 – 98

# Standard Test Method for Ranking Resistance of Materials to Sliding Wear Using Block-on-Ring Wear Test<sup>1</sup>

This standard is issued under the fixed designation G 77; the number immediately following the designation indicates the year of original adoption or, in the case of revision, the year of last revision. A number in parentheses indicates the year of last reapproval. A superscript epsilon ( $\epsilon$ ) indicates an editorial change since the last revision or reapproval.

## 1. Scope

1.1 This test method covers laboratory procedures for determining the resistance of materials to sliding wear. The test utilizes a block-on-ring friction and wear testing machine to rank pairs of materials according to their sliding wear characteristics under various conditions.

1.2 An important attribute of this test is that it is very flexible. Any material that can be fabricated into, or applied to, blocks and rings can be tested. However, the interlaboratory testing has been limited to metals. Thus, the potential materials combinations are endless. In addition, the test can be run with various lubricants, liquids, or gaseous atmospheres, as desired, to simulate service conditions. Rotational speed and load can also be varied to better correspond to service requirements.

1.3 Wear test results are reported as the volume loss in cubic millimetres for both the block and ring. Materials of higher wear resistance will have lower volume loss.

1.4 *This standard does not purport to address the safety concerns, if any, associated with its use. It is the responsibility of the user of this standard to establish appropriate safety and health practices and determine the applicability of regulatory limitations prior to use.*

## 2. Referenced Documents

### 2.1 ASTM Standards:

- D 2714 Test Method for Calibration and Operation of the Falex Block-on-Ring Friction and Wear Testing Machine<sup>2</sup>
- E 122 Practice for Choice of Sample Size to Estimate a Measure of Quality for a Lot or Process<sup>3</sup>
- E 177 Practice for Use of the Terms Precision and Bias in ASTM Test Methods<sup>3</sup>
- E 691 Practice for Conducting an Interlaboratory Study to Determine the Precision of a Test Method<sup>3</sup>
- G 40 Terminology Relating to Wear and Erosion<sup>4</sup>

<sup>1</sup> This test method is under the jurisdiction of ASTM Committee G-2 on Wear and Erosion and is the direct responsibility of Subcommittee G02.40 on Non-Abrasive Wear.

Current edition approved Oct. 10, 1998. Published January 1999. Originally published as G 77 – 83. Last previous edition G 77 – 97.

<sup>2</sup> *Annual Book of ASTM Standards*, Vol 05.02.

<sup>3</sup> *Annual Book of ASTM Standards*, Vol 14.02.

<sup>4</sup> *Annual Book of ASTM Standards*, Vol 03.02.

## 3. Terminology

### 3.1 Definition:

3.1.1 *wear*—damage to a solid surface, generally involving progressive loss of material, due to relative motion between that surface and a contacting substance or substances.

3.1.2 For additional definitions pertinent to this test method, see Terminology G 40.

## 4. Summary of Test Method

4.1 A test block is loaded against a test ring that rotates at a given speed for a given number of revolutions. Block scar volume is calculated from the block scar width, and ring scar volume is calculated from ring weight loss. The friction force required to keep the block in place is continuously measured during the test with a load cell. These data, combined with normal force data, are converted to coefficient of friction values and reported.

## 5. Significance and Use

5.1 The significance of this test method in any overall measurement program directed toward a service application will depend on the relative match of test conditions to the conditions of the service application.

5.2 This test method seeks only to prescribe the general test procedure and method of calculating and reporting data. The choice of test operating parameters is left to the user. A fixed amount of sliding distance must be used because wear is usually non-linear with distance in this test.

## 6. Apparatus and Materials

6.1 *Test Schematic*—A schematic of the block-on-ring wear test geometry is shown in Fig. 1.<sup>5</sup> Acceptable testing machines are shown in Appendix X1.

6.2 *Test Ring*—A typical test ring is shown in Fig. 2. The test ring must have an outer diameter of  $34.99 \pm 0.025$  mm ( $1.377 \pm 0.001$  in.) with an eccentricity between the inner and

<sup>5</sup> Several machines, including the current Falex Model I and the older Dow Corning LFW-1 machines, have been found satisfactory for the purposes of this test. These models may differ in lever arm ratio, load range, speed control (variable or fixed), speed range, and type of friction measuring device. Suitable machines may be purchased from Falex Corporation, 1020 Airpark Dr., Sugar Grove, IL 60554.

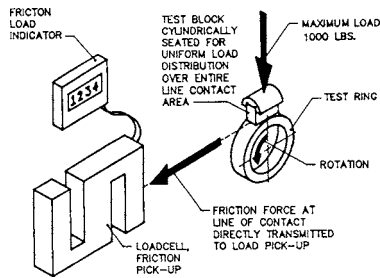

**FIG. 1 Test Schematic**

outer surface of no greater than 0.00125 mm (0.0005 in.). For couples where surface condition is not under study, it is recommended that the outer diameter be a ground surface with a roughness of 0.152 to 0.305  $\mu\text{m}$  (6 to 12  $\mu\text{in.}$ ) rms or center line average (CLA), in the direction of motion. However, alternate surface conditions may be evaluated in the test, as desired. It should be kept in mind that surface condition can have an effect on sliding wear results.

6.3 *Test Block*—A test block is shown in Fig. 3. Block width is  $6.35 + 0.000, -0.025$  mm ( $0.250 + 0.000, -0.001$  in.). For couples where surface condition is not a parameter under study, a ground surface with the grinding marks running parallel to the long axis of the block and a roughness of 0.102 to 0.203  $\mu\text{m}$  (4 to 8  $\mu\text{in.}$ ) CLA in the direction of motion is recommended. However, other surface conditions may be evaluated as desired.

6.4 *Analytical Balance*, capable of measuring to the nearest 0.1 mg.

6.5 *Optical device* (or equivalent), with metric or inch-pound unit calibration, is also necessary so that scar width can be measured with a precision of 0.005 mm (0.0002 in.) or equivalent.

## 7. Reagents

- 7.1 *Trichloroethane*.
- 7.2 *Methanol*.

## 8. Preparation and Calibration of Apparatus

8.1 Run the calibration procedure that is in Test Method D 2714 to ensure good mechanical operation of the test equipment.

## 9. Procedure

9.1 Clean the block and ring using a procedure that will remove any scale, oil film, or residue without damaging the surface.

9.1.1 For metals, the following procedure is recommended: clean the block and ring in trichloroethane, ultrasonically, if possible; a methanol rinse may be used to remove any traces of trichloroethane residue. Allow the blocks and rings to dry completely. Handle the block and ring with clean, lint-free cotton gloves from this point on.

9.2 Make surface texture and surface roughness measurements across the width of the block and the ring, as necessary. Note that a surface profile does not completely describe a surface topology. Scanning electron micrographs may be used,

as desired, to augment the description of the wear surfaces. Clean the block and the ring if necessary as in 9.1.

9.3 Demagnetize the metal specimens and ferrous assembly. Weigh the block and ring to the nearest 0.1 mg.

9.4 Measure the block width and ring diameter to the nearest 0.05 mm (0.002 in.).

9.5 Clean the hemispherical block holder, ring shaft, and lubricant reservoir with trichloroethane.<sup>6</sup>

9.6 Put the hemispherical block holder on the block.<sup>6</sup>

9.7 Place the block in position on the machine and, while holding the block in position, place the ring on the shaft and lock the ring in place, using a torque wrench in accordance with the requirements of the specific machine design.<sup>6</sup>

9.8 Center the block on the ring while placing a light manual pressure on the lever arm to bring the block and ring into contact.<sup>6</sup> Be sure the edge of the block is parallel to the edge of the ring and that the mating surfaces are perfectly aligned. This is accomplished by making sure the specimen holder is free during mounting so that the quarter segment can properly seat itself. Release the pressure on the lever arm.

9.9 One may choose either a preloading or a step-loading procedure. Generally, preloading is chosen for variable speed machines, while step-loading is chosen for fixed speed machines in order to avoid an initial high wear transient. The differences in the two procedures are indicated in 9.10-9.22.

9.10 Place the required weights on the load bale and adjust the lever arm in accordance with the requirements of the specific machine design.<sup>6</sup> Then remove the load by raising the weights, if using the preloading procedure, or by removing the weights if using the step-loading procedure.

9.11 If running a lubricated test, clean all components that will come in contact with lubricant; fill the lubricant reservoir with lubricant to 6.4 mm (0.25 in.) above the lower surface of the ring; rotate the ring several times.

9.12 Set the revolution counter to zero.<sup>6</sup>

9.13 Gently lower the weights, applying the required load, if using the preloading procedure.

9.14 If using a variable speed machine, turn on the machine and slowly increase the power to the drive motor until the ring starts to rotate, recording the “static” friction force. Continue to increase the rate of rotation to the desired rate. If using a fixed speed machine, simply turn on the machine.

9.15 If using step-loading, start the machine with no weights, then gently add a 133-N (30-lbf) load every 200 rev until the required test load is reached. Adjust the rate of rotation as needed. If the required load is less than 133 N, apply the load in one step.

9.16 During the test, record the friction force, lubricant or block temperature, as required, and, if desired, the vertical displacement of the block.

9.17 Stop the test manually or automatically after the desired number of revolutions.<sup>7</sup>

<sup>6</sup> These instructions are appropriate for the machines shown in Appendix X1. The instructions may be modified, as necessary, by the user to fit the requirements of alternate machine designs.

<sup>7</sup> 5,400 and 10 800 revolutions have been used for metals in interlaboratory test programs.

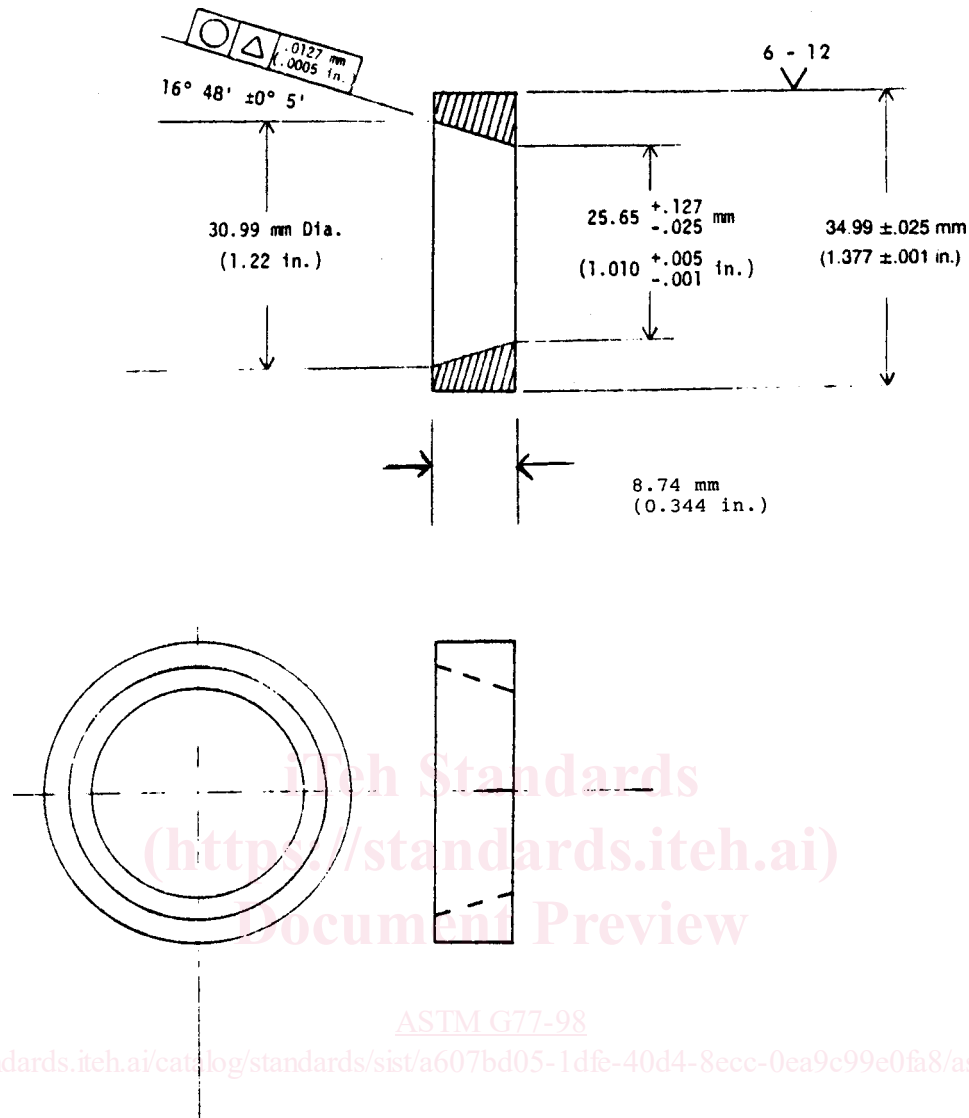

ASTM G77-98

<https://standards.itech.ai/catalog/standards/sist/a607bd05-1dfe-40d4-8ecc-0ea9c99e0fa8/astm-g77-98>

NOTE 1—The outer diameter and concentricity with the inner diameter are the only critical parameters. The inner diameter is optional depending on machine design. The inside diameter taper shown fits a number of standard machines.

FIG. 2 Test Ring

9.18 A final “static” friction force may be measured with a variable speed machine. Leaving on the full load, wait 3 min ± 10 s, then turn on the machine and slowly increase the power to the drive motor until the ring starts to rotate, recording the “static” final friction force. Then turn off the motor.

9.19 Remove the block and ring, clean, and reweigh to the nearest 0.1 mg. For metals use trichloroethane.

9.20 Make surface roughness measurements and profilometer traces across the width of the block and the ring as desired. A trace along the long axis of the block, through the wear scar, is also useful to verify the scar depth and shape.<sup>8</sup>

<sup>8</sup> On some of the old test machines, it is possible for the block to move back and forth slightly, increasing the apparent size of the wear scar. This is generally not a problem on the more rigid Falex machines. If this problem is suspected, a profilometer trace through the wear scar will verify whether or not the scar shape corresponds to the curvature of the ring.

9.21 Measure the scar width on the test block in the center and ~1 mm (0.04 in.) away from each edge. These measurements shall be to the nearest 0.1 mm (0.004 in.). Record the average of the three readings. Sometimes oxidation debris or a lip of plastically deformed material will extend over the edge of the wear scar (Fig. 4). When measuring scar width, try to visually ignore this material or measure the scar width in an area where this is not a problem.

9.22 Tapered scars indicate improper block alignment during testing. If the three width measurements on a given scar have a coefficient of variation of greater than 10 %, the test shall be declared invalid.

## 10. Calculation

### 10.1 Calculation of Block Scar Volume:

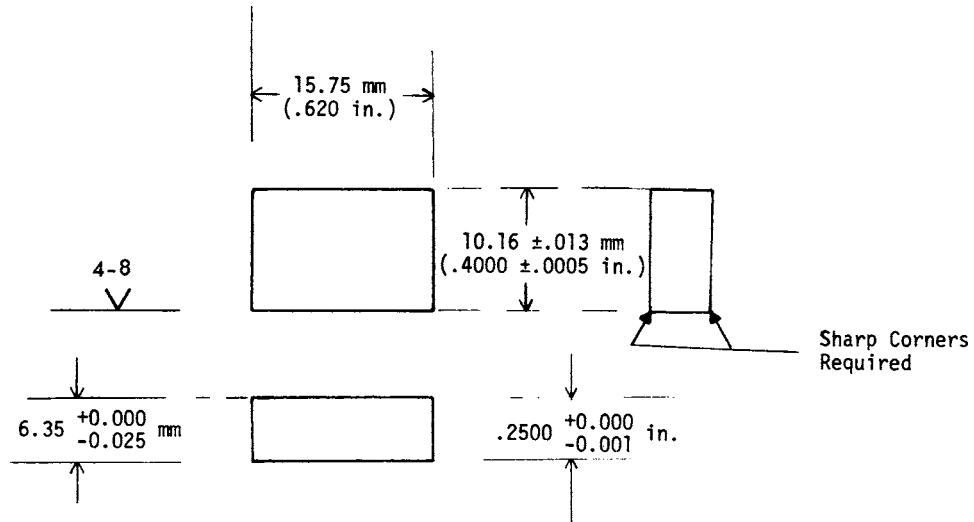
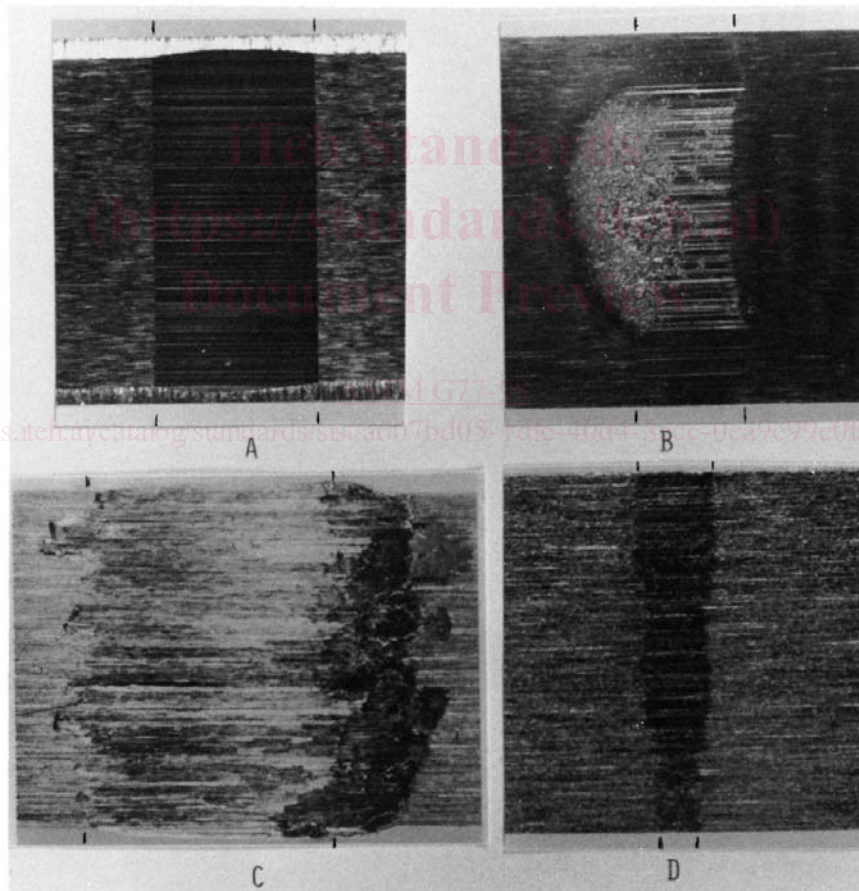

FIG. 3 Test Block



- A good rectangular scar with straight edges.
- The center of the scar is curved because the block was crowned. Also, debris covers the center left edge of the scar. Ordinarily, the debris should be visually ignored, but in this case scar curvature makes this too difficult. The test should be rerun.
- Severe galling resulted in jagged scar edges and a lip of plastically deformed material along the right side of the scar. The raised lip of material is excluded from the scar measurement. The cross hair should be run to a visual average of the jagged edge, not to the point of a zigzag.
- Tapered scar with jagged edges. This scar is too tapered (coefficient of variation > 10 %); therefore, the test should be rerun.

FIG. 4 Block Scars

**TABLE 1 Block Scar Widths and Volumes for Blocks 6.35-mm Wide Mated Against Rings 34.99 mm in Diameter**

| Block Scar Width (mm) | Volume (mm <sup>3</sup> ) | Width (mm) | Volume (mm <sup>3</sup> ) | Width (mm) | Volume (mm <sup>3</sup> ) | Block Scar Width (mm) | Volume (mm <sup>3</sup> ) | Width (mm) | Volume (mm <sup>3</sup> ) | Width (mm) | Volume (mm <sup>3</sup> ) |
|-----------------------|---------------------------|------------|---------------------------|------------|---------------------------|-----------------------|---------------------------|------------|---------------------------|------------|---------------------------|
| 0.30                  | 0.0008                    | 1.01       | 0.0312                    | 1.72       | 0.1541                    | 2.42                  | 0.4295                    | 3.12       | 0.9212                    | 3.83       | 1.7062                    |
| 0.31                  | 0.0009                    | 1.02       | 0.0321                    | 1.73       | 0.1568                    | 2.43                  | 0.4348                    | 3.13       | 0.9301                    | 3.84       | 1.7196                    |
| 0.32                  | 0.0010                    | 1.03       | 0.0331                    | 1.74       | 0.1595                    | 2.44                  | 0.4402                    | 3.14       | 0.9391                    | 3.85       | 1.7331                    |
| 0.33                  | 0.0011                    | 1.04       | 0.0340                    | 1.75       | 0.1623                    | 2.45                  | 0.4456                    | 3.15       | 0.9481                    | 3.86       | 1.7467                    |
| 0.34                  | 0.0012                    | 1.05       | 0.0350                    | 1.76       | 0.1651                    | 2.46                  | 0.4511                    | 3.16       | 0.9572                    | 3.87       | 1.7603                    |
| 0.35                  | 0.0013                    | 1.06       | 0.0360                    | 1.77       | 0.1679                    | 2.47                  | 0.4567                    | 3.17       | 0.9663                    | 3.88       | 1.7740                    |
| 0.36                  | 0.0014                    | 1.07       | 0.0371                    | 1.78       | 0.1708                    | 2.48                  | 0.4622                    | 3.18       | 0.9755                    | 3.89       | 1.7878                    |
| 0.37                  | 0.0015                    | 1.08       | 0.0381                    | 1.79       | 0.1737                    | 2.49                  | 0.4679                    | 3.19       | 0.9847                    | 3.90       | 1.8017                    |
| 0.38                  | 0.0017                    | 1.09       | 0.0392                    | 1.80       | 0.1766                    | 2.50                  | 0.4735                    | 3.20       | 0.9940                    | 3.91       | 1.8156                    |
| 0.39                  | 0.0018                    | 1.10       | 0.0403                    | 1.81       | 0.1796                    | 2.51                  | 0.4792                    | 3.21       | 1.0034                    | 3.92       | 1.8296                    |
| 0.40                  | 0.0019                    | 1.11       | 0.0414                    | 1.82       | 0.1826                    | 2.52                  | 0.4850                    | 3.22       | 1.0128                    | 3.93       | 1.8437                    |
| 0.41                  | 0.0021                    | 1.12       | 0.0425                    | 1.83       | 0.1856                    | 2.53                  | 0.4908                    | 3.23       | 1.0223                    | 3.94       | 1.8578                    |
| 0.42                  | 0.0022                    | 1.13       | 0.0437                    | 1.84       | 0.1887                    | 2.54                  | 0.4966                    | 3.24       | 1.0318                    | 3.95       | 1.8720                    |
| 0.43                  | 0.0024                    | 1.13       | 0.0448                    | 1.85       | 0.1917                    | 2.55                  | 0.5025                    | 3.25       | 1.0414                    | 3.96       | 1.8863                    |
| 0.44                  | 0.0026                    | 1.15       | 0.0460                    | 1.86       | 0.1949                    | 2.56                  | 0.5085                    | 3.26       | 1.0511                    | 3.97       | 1.9007                    |
| 0.45                  | 0.0028                    | 1.16       | 0.0472                    | 1.87       | 0.1980                    | 2.57                  | 0.5145                    | 3.27       | 1.0608                    | 3.98       | 1.9151                    |
| 0.46                  | 0.0029                    | 1.17       | 0.0485                    | 1.88       | 0.2012                    | 2.58                  | 0.5205                    | 3.28       | 1.0706                    | 3.99       | 1.9296                    |
| 0.47                  | 0.0031                    | 1.18       | 0.0497                    | 1.89       | 0.2045                    | 2.59                  | 0.5266                    | 3.29       | 1.0804                    |            |                           |
| 0.48                  | 0.0033                    | 1.19       | 0.0510                    | 1.90       | 0.2077                    | 2.60                  | 0.5327                    | 3.30       | 1.0903                    | 4.00       | 1.9442                    |
| 0.49                  | 0.0036                    | 1.20       | 0.0523                    | 1.91       | 0.2110                    | 2.61                  | 0.5389                    | 3.31       | 1.1003                    | 4.01       | 1.9589                    |
| 0.50                  | 0.0038                    | 1.21       | 0.0536                    | 1.92       | 0.2144                    | 2.62                  | 0.5451                    | 3.32       | 1.1103                    | 4.02       | 1.9736                    |
| 0.51                  | 0.0040                    | 1.22       | 0.0550                    | 1.93       | 0.2177                    | 2.63                  | 0.5514                    | 3.33       | 1.1204                    | 4.03       | 1.9884                    |
| 0.52                  | 0.0043                    | 1.23       | 0.0563                    | 1.94       | 0.2211                    | 2.64                  | 0.5577                    | 3.34       | 1.1305                    | 4.04       | 2.0033                    |
| 0.53                  | 0.0045                    | 1.24       | 0.0577                    | 1.95       | 0.2246                    | 2.65                  | 0.5641                    | 3.35       | 1.1407                    | 4.05       | 2.0183                    |
| 0.54                  | 0.0048                    | 1.25       | 0.0591                    | 1.96       | 0.2281                    | 2.66                  | 0.5705                    | 3.36       | 1.1510                    | 4.06       | 2.0333                    |
| 0.55                  | 0.0050                    | 1.26       | 0.0606                    | 1.97       | 0.2316                    | 2.67                  | 0.5770                    | 3.37       | 1.1613                    | 4.07       | 2.0484                    |
| 0.56                  | 0.0053                    | 1.27       | 0.0620                    | 1.98       | 0.235                     | 2.68                  | 0.5835                    | 3.38       | 1.1717                    | 4.08       | 2.0636                    |
| 0.57                  | 0.0056                    | 1.28       | 0.0635                    | 1.99       | 0.2387                    | 2.69                  | 0.5900                    | 3.39       | 1.1822                    | 4.09       | 2.0788                    |
| 0.58                  | 0.0059                    | 1.29       | 0.0650                    |            |                           | 2.70                  | 0.5967                    | 3.40       | 1.1927                    | 4.10       | 2.0941                    |
| 0.59                  | 0.0062                    | 1.30       | 0.0665                    | 2.00       | 0.2423                    | 2.71                  | 0.6033                    | 3.41       | 1.2033                    | 4.11       | 2.1095                    |
| 0.60                  | 0.0065                    | 1.31       | 0.0681                    | 2.01       | 0.2460                    | 2.72                  | 0.6100                    | 3.42       | 1.2139                    | 4.12       | 2.1250                    |
| 0.61                  | 0.0069                    | 1.32       | 0.0696                    | 2.02       | 0.2497                    | 2.73                  | 0.6168                    | 3.43       | 1.2246                    | 4.13       | 2.1406                    |
| 0.62                  | 0.0072                    | 1.33       | 0.0712                    | 2.03       | 0.2534                    | 2.74                  | 0.6236                    | 3.44       | 1.2353                    | 4.14       | 2.1562                    |
| 0.63                  | 0.0076                    | 1.34       | 0.0728                    | 2.04       | 0.2572                    | 2.75                  | 0.6305                    | 3.45       | 1.2462                    | 4.15       | 2.1719                    |
| 0.64                  | 0.0079                    | 1.35       | 0.0745                    | 2.05       | 0.2610                    | 2.76                  | 0.6374                    | 3.46       | 1.2571                    | 4.16       | 2.1877                    |
| 0.65                  | 0.0083                    | 1.36       | 0.0761                    | 2.06       | 0.2648                    | 2.77                  | 0.6443                    | 3.47       | 1.2680                    | 4.17       | 2.2036                    |
| 0.66                  | 0.0087                    | 1.37       | 0.0778                    | 2.07       | 0.2687                    | 2.78                  | 0.6513                    | 3.48       | 1.2790                    | 4.18       | 2.2195                    |
| 0.67                  | 0.0091                    | 1.38       | 0.0796                    | 2.08       | 0.2726                    | 2.79                  | 0.6584                    | 3.49       | 1.2901                    | 4.19       | 2.2355                    |
| 0.68                  | 0.0095                    | 1.39       | 0.0813                    | 2.09       | 0.2765                    | 2.80                  | 0.6655                    | 3.50       | 1.3013                    | 4.20       | 2.2516                    |
| 0.69                  | 0.0099                    | 1.40       | 0.0831                    | 2.10       | 0.2805                    | 2.81                  | 0.6727                    | 3.51       | 1.3125                    | 4.21       | 2.2678                    |
| 0.70                  | 0.0104                    | 1.41       | 0.0849                    | 2.11       | 0.2846                    | 2.82                  | 0.6799                    | 3.52       | 1.3238                    | 4.22       | 2.2840                    |
| 0.71                  | 0.0108                    | 1.42       | 0.0867                    | 2.12       | 0.2886                    | 2.83                  | 0.6872                    | 3.53       | 1.3351                    | 4.23       | 2.3003                    |
| 0.72                  | 0.0113                    | 1.43       | 0.0885                    | 2.13       | 0.2927                    | 2.84                  | 0.6945                    | 3.54       | 1.3465                    | 4.24       | 2.3167                    |
| 0.73                  | 0.0118                    | 1.44       | 0.0904                    | 2.14       | 0.2969                    | 2.85                  | 0.7019                    | 3.55       | 1.3580                    | 4.25       | 2.3332                    |
| 0.74                  | 0.0123                    | 1.45       | 0.0923                    | 2.15       | 0.3011                    | 2.86                  | 0.7093                    | 3.56       | 1.3695                    | 4.26       | 2.3498                    |
| 0.75                  | 0.0128                    | 1.46       | 0.0942                    | 2.16       | 0.3053                    | 2.87                  | 0.7168                    | 3.57       | 1.3811                    | 4.27       | 2.3664                    |
| 0.76                  | 0.0133                    | 1.47       | 0.0962                    | 2.17       | 0.3096                    | 2.88                  | 0.7243                    | 3.58       | 1.3928                    | 4.28       | 2.3831                    |
| 0.77                  | 0.0138                    | 1.48       | 0.0981                    | 2.18       | 0.3139                    | 2.89                  | 0.7319                    | 3.59       | 1.4045                    | 4.29       | 2.3999                    |
| 0.78                  | 0.0144                    | 1.49       | 0.1001                    | 2.19       | 0.3182                    | 2.90                  | 0.7395                    | 3.60       | 1.4163                    | 4.30       | 2.4168                    |
| 0.79                  | 0.0149                    | 1.50       | 0.1022                    | 2.20       | 0.3226                    | 2.91                  | 0.7472                    | 3.61       | 1.4281                    | 4.31       | 2.4338                    |
| 0.80                  | 0.0155                    | 1.51       | 0.1042                    | 2.21       | 0.3270                    | 2.92                  | 0.7549                    | 3.62       | 1.4401                    | 4.32       | 2.4508                    |
| 0.81                  | 0.0161                    | 1.52       | 0.1063                    | 2.22       | 0.3315                    | 2.93                  | 0.7627                    | 3.63       | 1.4521                    | 4.33       | 2.4679                    |
| 0.82                  | 0.0167                    | 1.53       | 0.1084                    | 2.23       | 0.3360                    | 2.94                  | 0.7706                    | 3.64       | 1.4641                    | 4.34       | 2.4851                    |
| 0.83                  | 0.0173                    | 1.54       | 0.1106                    | 2.24       | 0.3405                    | 2.95                  | 0.7785                    | 3.65       | 1.4762                    | 4.35       | 2.5024                    |
| 0.84                  | 0.0179                    | 1.55       | 0.1127                    | 2.25       | 0.3451                    | 2.96                  | 0.7864                    | 3.66       | 1.4884                    | 4.36       | 2.4197                    |
| 0.85                  | 0.0186                    | 1.56       | 0.1149                    | 2.26       | 0.3497                    | 2.97                  | 0.7944                    | 3.67       | 1.5007                    | 4.37       | 2.5371                    |
| 0.86                  | 0.0192                    | 1.57       | 0.1172                    | 2.27       | 0.3544                    | 2.98                  | 0.8025                    | 3.68       | 1.5130                    | 4.38       | 2.5547                    |
| 0.87                  | 0.0199                    | 1.58       | 0.1194                    | 2.28       | 0.3691                    | 2.99                  | 0.8106                    | 3.69       | 1.5254                    | 4.39       | 2.5723                    |
| 0.88                  | 0.0206                    | 1.59       | 0.1217                    | 2.29       | 0.3638                    |                       |                           | 3.70       | 1.5379                    | 4.40       | 2.5899                    |
| 0.89                  | 0.0213                    | 1.60       | 0.1240                    | 2.30       | 0.3686                    | 3.00                  | 0.8188                    | 3.71       | 1.5504                    | 4.41       | 2.6077                    |
| 0.90                  | 0.0221                    | 1.61       | 0.1264                    | 2.31       | 0.3735                    | 3.01                  | 0.8270                    | 3.72       | 1.5630                    | 4.42       | 2.6255                    |
| 0.91                  | 0.0228                    | 1.62       | 0.1287                    | 2.32       | 0.3783                    | 3.02                  | 0.8353                    | 3.73       | 1.5757                    | 4.43       | 2.6434                    |
| 0.92                  | 0.0236                    | 1.63       | 0.1311                    | 2.33       | 0.3833                    | 3.03                  | 0.8437                    | 3.74       | 1.5884                    | 4.44       | 2.6614                    |
| 0.93                  | 0.0243                    | 1.64       | 0.1336                    | 2.34       | 0.3882                    | 3.04                  | 0.8520                    | 3.75       | 1.6012                    | 4.45       | 2.6795                    |
| 0.94                  | 0.0251                    | 1.65       | 0.1360                    | 2.35       | 0.3932                    | 3.05                  | 0.8605                    | 3.76       | 1.6141                    | 4.46       | 2.6977                    |
| 0.95                  | 0.0259                    | 1.66       | 0.1385                    | 2.36       | 0.3983                    | 3.06                  | 0.8690                    | 3.77       | 1.6270                    | 4.47       | 2.7159                    |
| 0.96                  | 0.0268                    | 1.67       | 0.1410                    | 2.37       | 0.4034                    | 3.07                  | 0.8776                    | 3.78       | 1.6401                    | 4.48       | 2.7343                    |
| 0.97                  | 0.0276                    | 1.68       | 0.1436                    | 2.38       | 0.4085                    | 3.08                  | 0.8862                    | 3.79       | 1.6531                    | 4.49       | 2.7527                    |
| 0.98                  | 0.0285                    | 1.69       | 0.1462                    | 2.39       | 0.4137                    | 3.09                  | 0.8948                    | 3.80       | 1.6663                    | 4.50       | 2.7712                    |
| 0.99                  | 0.0294                    | 1.70       | 0.1488                    | 2.40       | 0.4189                    | 3.10                  | 0.9036                    | 3.81       | 1.6795                    | 4.51       | 2.7897                    |
| 1.00                  | 0.0303                    | 1.71       | 0.1514                    | 2.41       | 0.4242                    | 3.11                  | 0.9124                    | 3.82       | 1.6928                    | 4.52       | 2.8084                    |
| 4.53                  | 2.8272                    | 4.91       | 3.6032                    | 5.28       | 4.4849                    | 5.66                  | 5.5303                    | 6.03       | 6.6946                    | 6.41       | 8.0512                    |

**TABLE 1 Continued**

| Block Scar Width (mm) | Volume (mm <sup>3</sup> ) | Width (mm) | Volume (mm <sup>3</sup> ) | Width (mm) | Volume (mm <sup>3</sup> ) | Block Scar Width (mm) | Volume (mm <sup>3</sup> ) | Width (mm) | Volume (mm <sup>3</sup> ) | Width (mm) | Volume (mm <sup>3</sup> ) |
|-----------------------|---------------------------|------------|---------------------------|------------|---------------------------|-----------------------|---------------------------|------------|---------------------------|------------|---------------------------|
| 4.54                  | 2.8460                    | 4.92       | 3.6253                    | 5.29       | 4.5105                    | 5.67                  | 5.5599                    | 6.04       | 6.7282                    | 6.42       | 8.0892                    |
| 4.55                  | 2.8649                    | 4.93       | 3.6476                    | 5.30       | 4.5363                    | 5.68                  | 5.5895                    | 6.05       | 6.7618                    | 6.43       | 8.1274                    |
| 4.56                  | 2.8839                    | 4.94       | 3.6699                    | 5.31       | 4.5621                    | 5.69                  | 5.6192                    | 6.06       | 6.7956                    | 6.44       | 8.1656                    |
| 4.57                  | 2.9030                    | 4.95       | 3.6923                    | 5.32       | 4.5881                    | 5.70                  | 5.6491                    | 6.07       | 6.8295                    | 6.45       | 8.2040                    |
| 4.58                  | 2.9221                    | 4.96       | 3.7148                    | 5.33       | 4.6141                    | 5.71                  | 5.6790                    | 6.08       | 6.8636                    | 6.46       | 8.2425                    |
| 4.59                  | 2.9414                    | 4.97       | 3.7375                    | 5.34       | 4.6403                    | 5.72                  | 5.7091                    | 6.09       | 6.8977                    | 6.47       | 8.2811                    |
| 4.60                  | 2.9607                    | 4.98       | 3.7601                    | 5.35       | 4.6665                    | 5.73                  | 5.7392                    | 6.10       | 6.9319                    | 6.48       | 8.3198                    |
| 4.61                  | 2.9801                    | 4.99       | 3.7829                    | 5.36       | 4.6929                    | 5.74                  | 5.7695                    | 6.11       | 6.9663                    | 6.49       | 8.3586                    |
| 4.62                  | 2.9996                    |            |                           | 5.37       | 4.7193                    | 5.75                  | 5.7999                    | 6.12       | 7.0008                    | 6.50       | 8.3976                    |
| 4.63                  | 3.0192                    | 5.00       | 3.8058                    | 5.38       | 4.7458                    | 5.76                  | 5.8303                    | 6.13       | 7.0354                    | 6.51       | 8.4367                    |
| 4.64                  | 3.0389                    | 5.01       | 3.8288                    | 5.39       | 4.7725                    | 5.77                  | 5.8609                    | 6.14       | 7.0701                    | 6.52       | 8.4759                    |
| 4.65                  | 3.0587                    | 5.02       | 3.8519                    | 5.40       | 4.7992                    | 5.78                  | 5.8916                    | 6.15       | 7.1049                    | 6.53       | 8.5153                    |
| 4.66                  | 3.0785                    | 5.03       | 3.8750                    | 5.41       | 4.8261                    | 5.79                  | 5.9224                    | 6.16       | 7.1398                    | 6.54       | 8.5547                    |
| 4.67                  | 3.0984                    | 5.04       | 3.8983                    | 5.42       | 4.8530                    | 5.80                  | 5.9533                    | 6.17       | 7.1749                    | 6.55       | 8.5943                    |
| 4.68                  | 3.1185                    | 5.05       | 3.9216                    | 5.43       | 4.8800                    | 5.81                  | 5.9844                    | 6.18       | 7.2100                    | 6.56       | 8.6340                    |
| 4.69                  | 3.1386                    | 5.06       | 3.9451                    | 5.44       | 4.9072                    | 5.82                  | 6.0155                    | 6.19       | 7.2453                    | 6.57       | 8.6739                    |
| 4.70                  | 3.1588                    | 5.07       | 3.9686                    | 5.45       | 4.9344                    | 5.83                  | 6.0467                    | 6.20       | 7.2807                    | 6.58       | 8.7138                    |
| 4.71                  | 3.1790                    | 5.08       | 3.9922                    | 5.46       | 4.9618                    | 5.84                  | 6.0781                    | 6.21       | 7.3162                    | 6.59       | 8.7539                    |
| 4.72                  | 3.1994                    | 5.09       | 4.0160                    | 5.47       | 4.9892                    | 5.85                  | 6.1095                    | 6.22       | 7.3519                    | 6.60       | 8.7941                    |
| 4.73                  | 3.2199                    | 5.10       | 4.0398                    | 5.48       | 5.0168                    | 5.86                  | 6.1411                    | 6.23       | 7.3876                    | 6.61       | 8.8344                    |
| 4.74                  | 3.2404                    | 5.11       | 4.0637                    | 5.49       | 5.0444                    | 5.87                  | 6.1728                    | 6.24       | 7.4235                    | 6.62       | 8.8749                    |
| 4.75                  | 3.2610                    | 5.12       | 4.0877                    | 5.50       | 5.0722                    | 5.88                  | 6.2045                    | 6.25       | 7.4595                    | 6.63       | 8.9154                    |
| 4.76                  | 3.2818                    | 5.13       | 4.1118                    | 5.51       | 5.1001                    | 5.89                  | 6.2364                    | 6.26       | 7.4956                    | 6.64       | 8.9562                    |
| 4.77                  | 3.3026                    | 5.14       | 4.1360                    | 5.52       | 5.1280                    | 5.90                  | 6.2684                    | 6.27       | 7.5318                    | 6.65       | 8.9970                    |
| 4.78                  | 3.3235                    | 5.15       | 4.1603                    | 5.53       | 5.1561                    | 5.91                  | 6.3006                    | 6.28       | 7.5681                    | 6.66       | 9.0379                    |
| 4.79                  | 3.3444                    | 5.16       | 4.1847                    | 5.54       | 5.1842                    | 5.92                  | 6.3328                    | 6.29       | 7.6046                    | 6.67       | 9.0790                    |
| 4.80                  | 3.3655                    | 5.17       | 4.2092                    | 5.55       | 5.2125                    | 5.93                  | 6.3651                    | 6.30       | 7.6411                    | 6.68       | 9.1202                    |
| 4.81                  | 3.3867                    | 5.18       | 4.2338                    | 5.56       | 5.2409                    | 5.94                  | 6.3976                    | 6.31       | 7.6778                    | 6.69       | 9.1615                    |
| 4.82                  | 3.4079                    | 5.19       | 4.2584                    | 5.57       | 5.2694                    | 5.95                  | 6.4301                    | 6.32       | 7.7146                    | 6.70       | 9.2030                    |
| 4.83                  | 3.4293                    | 5.20       | 4.2832                    | 5.58       | 5.2979                    | 5.96                  | 6.4628                    | 6.33       | 7.7515                    | 6.71       | 9.2446                    |
| 4.84                  | 3.4507                    | 5.21       | 4.3081                    | 5.59       | 5.3266                    | 5.97                  | 6.4956                    | 6.34       | 7.7886                    | 6.72       | 9.2863                    |
| 4.85                  | 3.4722                    | 5.22       | 4.3330                    | 5.60       | 5.3554                    | 5.98                  | 6.5285                    | 6.35       | 7.8258                    | 6.73       | 9.3281                    |
| 4.86                  | 3.4938                    | 5.23       | 4.3581                    | 5.61       | 5.3843                    | 5.99                  | 6.5615                    | 6.36       | 7.8630                    | 6.74       | 9.3701                    |
| 4.87                  | 3.5155                    | 5.24       | 4.3833                    | 5.62       | 5.4133                    |                       |                           | 6.37       | 7.9004                    | 6.75       | 9.4122                    |
| 4.88                  | 3.5373                    | 5.25       | 4.4085                    | 5.63       | 5.4424                    | 6.00                  | 6.5946                    | 6.38       | 7.9380                    | 6.76       | 9.4544                    |
| 4.89                  | 3.5592                    | 5.26       | 4.4339                    | 5.64       | 5.4716                    | 6.01                  | 6.6278                    | 6.39       | 7.9756                    |            |                           |
| 4.90                  | 3.5811                    | 5.27       | 4.4593                    | 5.65       | 5.5009                    | 6.02                  | 6.6611                    | 6.40       | 8.0134                    |            |                           |
| 4.53                  | 2.8272                    | 4.91       | 3.6032                    | 5.28       | 4.4849                    | 5.66                  | 5.5303                    | 6.03       | 6.6946                    | 6.41       | 8.0512                    |
| 4.54                  | 2.8460                    | 4.92       | 3.6253                    | 5.29       | 4.5105                    | 5.67                  | 5.5599                    | 6.04       | 6.7282                    | 6.42       | 8.0892                    |
| 4.55                  | 2.8649                    | 4.93       | 3.6476                    | 5.30       | 4.5363                    | 5.68                  | 5.5895                    | 6.05       | 6.7618                    | 6.43       | 8.1274                    |
| 4.56                  | 2.8839                    | 4.94       | 3.6699                    | 5.31       | 4.5621                    | 5.69                  | 5.6192                    | 6.06       | 6.7956                    | 6.44       | 8.1656                    |
| 4.57                  | 2.9030                    | 4.95       | 3.6923                    | 5.32       | 4.5881                    | 5.70                  | 5.6491                    | 6.07       | 6.8295                    | 6.45       | 8.2040                    |
| 4.58                  | 2.9221                    | 4.96       | 3.7148                    | 5.33       | 4.6141                    | 5.71                  | 5.6790                    | 6.08       | 6.8636                    | 6.46       | 8.2425                    |
| 4.59                  | 2.9414                    | 4.97       | 3.7375                    | 5.34       | 4.6403                    | 5.72                  | 5.7091                    | 6.09       | 6.8977                    | 6.47       | 8.2811                    |
| 4.60                  | 2.9607                    | 4.98       | 3.7601                    | 5.35       | 4.6665                    | 5.73                  | 5.7392                    | 6.10       | 6.9319                    | 6.48       | 8.3198                    |
| 4.61                  | 2.9801                    | 4.99       | 3.7829                    | 5.36       | 4.6929                    | 5.74                  | 5.7695                    | 6.11       | 6.9663                    | 6.49       | 8.3586                    |
| 4.62                  | 2.9996                    |            |                           | 5.37       | 4.7193                    | 5.75                  | 5.7999                    | 6.12       | 7.0008                    | 6.50       | 8.3976                    |
| 4.63                  | 3.0192                    | 5.00       | 3.8058                    | 5.38       | 4.7458                    | 5.76                  | 5.8303                    | 6.13       | 7.0354                    | 6.51       | 8.4367                    |
| 4.64                  | 3.0389                    | 5.01       | 3.8288                    | 5.39       | 4.7725                    | 5.77                  | 5.8609                    | 6.14       | 7.0701                    | 6.52       | 8.4759                    |
| 4.65                  | 3.0587                    | 5.02       | 3.8519                    | 5.40       | 4.7992                    | 5.78                  | 5.8916                    | 6.15       | 7.1049                    | 6.53       | 8.5153                    |
| 4.66                  | 3.0785                    | 5.03       | 3.8750                    | 5.41       | 4.8261                    | 5.79                  | 5.9224                    | 6.16       | 7.1398                    | 6.54       | 8.5547                    |
| 4.67                  | 3.0984                    | 5.04       | 3.8983                    | 5.42       | 4.8530                    | 5.80                  | 5.9533                    | 6.17       | 7.1749                    | 6.55       | 8.5943                    |
| 4.68                  | 3.1185                    | 5.05       | 3.9216                    | 5.43       | 4.8800                    | 5.81                  | 5.9844                    | 6.18       | 7.2100                    | 6.56       | 8.6340                    |
| 4.69                  | 3.1386                    | 5.06       | 3.9451                    | 5.44       | 4.9072                    | 5.82                  | 6.0155                    | 6.19       | 7.2453                    | 6.57       | 8.6739                    |
| 4.70                  | 3.1588                    | 5.07       | 3.9686                    | 5.45       | 4.9344                    | 5.83                  | 6.0467                    | 6.20       | 7.2807                    | 6.58       | 8.7138                    |
| 4.71                  | 3.1790                    | 5.08       | 3.9922                    | 5.46       | 4.9618                    | 5.84                  | 6.0781                    | 6.21       | 7.3162                    | 6.59       | 8.7539                    |
| 4.72                  | 3.1994                    | 5.09       | 4.0160                    | 5.47       | 4.9892                    | 5.85                  | 6.1095                    | 6.22       | 7.3519                    | 6.60       | 8.7941                    |
| 4.73                  | 3.2199                    | 5.10       | 4.0398                    | 5.48       | 5.0168                    | 5.86                  | 6.1411                    | 6.23       | 7.3876                    | 6.61       | 8.8344                    |
| 4.74                  | 3.2404                    | 5.11       | 4.0637                    | 5.49       | 5.0444                    | 5.87                  | 6.1728                    | 6.24       | 7.4235                    | 6.62       | 8.8749                    |
| 4.75                  | 3.2610                    | 5.12       | 4.0877                    | 5.50       | 5.0722                    | 5.88                  | 6.2045                    | 6.25       | 7.4595                    | 6.63       | 8.9154                    |
| 4.76                  | 3.2818                    | 5.13       | 4.1118                    | 5.51       | 5.1001                    | 5.89                  | 6.2364                    | 6.26       | 7.4956                    | 6.64       | 8.9562                    |
| 4.77                  | 3.3026                    | 5.14       | 4.1360                    | 5.52       | 5.1280                    | 5.90                  | 6.2684                    | 6.27       | 7.5318                    | 6.65       | 8.9970                    |
| 4.78                  | 3.3235                    | 5.15       | 4.1603                    | 5.53       | 5.1561                    | 5.91                  | 6.3006                    | 6.28       | 7.5681                    | 6.66       | 9.0379                    |
| 4.79                  | 3.3444                    | 5.16       | 4.1847                    | 5.54       | 5.1842                    | 5.92                  | 6.3328                    | 6.29       | 7.6046                    | 6.67       | 9.0790                    |
| 4.80                  | 3.3655                    | 5.17       | 4.2092                    | 5.55       | 5.2125                    | 5.93                  | 6.3651                    | 6.30       | 7.6411                    | 6.68       | 9.1202                    |
| 4.81                  | 3.3867                    | 5.18       | 4.2338                    | 5.56       | 5.2409                    | 5.94                  | 6.3976                    | 6.31       | 7.6778                    | 6.69       | 9.1615                    |
| 4.82                  | 3.4079                    | 5.19       | 4.2584                    | 5.57       | 5.2694                    | 5.95                  | 6.4301                    | 6.32       | 7.7146                    | 6.70       | 9.2030                    |
| 4.83                  | 3.4293                    | 5.20       | 4.2832                    | 5.58       | 5.2979                    | 5.96                  | 6.4628                    | 6.33       | 7.7515                    | 6.71       | 9.2446                    |
| 4.84                  | 3.4507                    | 5.21       | 4.3081                    | 5.59       | 5.3266                    | 5.97                  | 6.4956                    | 6.34       | 7.7886                    | 6.72       | 9.2863                    |
| 4.85                  | 3.4722                    | 5.22       | 4.3330                    | 5.60       | 5.3554                    | 5.98                  | 6.5285                    | 6.35       | 7.8258                    | 6.73       | 9.3281                    |
| 4.86                  | 3.4938                    | 5.23       | 4.3581                    | 5.61       | 5.3843                    | 5.99                  | 6.5615                    | 6.36       | 7.8630                    | 6.74       | 9.3701                    |
| 4.87                  | 3.5155                    | 5.24       | 4.3833                    | 5.62       | 5.4133                    |                       |                           | 6.37       | 7.9004                    | 6.75       | 9.4122                    |