



Designation: D8155 – 17

Standard Practice for Shake Extraction of Solid Mining and Metallurgical Processing Waste with Water¹

This standard is issued under the fixed designation D8155; the number immediately following the designation indicates the year of original adoption or, in the case of revision, the year of last revision. A number in parentheses indicates the year of last reapproval. A superscript epsilon (ϵ) indicates an editorial change since the last revision or reapproval.

1. Scope

1.1 This practice covers a procedure for leaching of solid waste to obtain an aqueous solution to be used to determine the constituents leached under the specified testing conditions.

1.1.1 This practice includes a procedure for the shake leaching of metal mining ore, waste rock, or metallurgical processing waste containing at least 80 % dry solids (≤ 20 % moisture) in order to generate a solution to be used to determine the inorganic constituents leached under the specified testing conditions and for regulatory jurisdictions requiring a water leach practice.

1.2 This practice provides for the shaking of a known mass of waste with water of specified composition and the separation of the aqueous phase for analysis.

1.2.1 This practice is intended to describe the procedure for performing single-batch extractions only. It does not describe all types of sampling, sample preservation, and analytical requirements that may be associated with its application.

1.3 The values stated in SI units are to be regarded as standard. Values given in parentheses are mathematical conversions to inch-pound units that are provided for information only and are not considered standard.

1.4 *This standard does not purport to address all of the safety concerns, if any, associated with its use. It is the responsibility of the user of this standard to establish appropriate safety, health, and environmental practices and determine the applicability of regulatory limitations prior to use.*

1.5 *This international standard was developed in accordance with internationally recognized principles on standardization established in the Decision on Principles for the Development of International Standards, Guides and Recommendations issued by the World Trade Organization Technical Barriers to Trade (TBT) Committee.*

¹ This practice is under the jurisdiction of ASTM Committee D34 on Waste Management and is the direct responsibility of Subcommittee D34.01.04 on Waste Leaching Techniques.

Current edition approved Dec. 15, 2017. Published December 2017. Originally approved in 2017. DOI: 10.1520/D8155-17.

2. Referenced Documents

2.1 ASTM Standards:²

C471M Test Methods for Chemical Analysis of Gypsum and Gypsum Products (Metric)

D75/D75M Practice for Sampling Aggregates

D420 Guide to Site Characterization for Engineering Design and Construction Purposes (Withdrawn 2011)³

D1193 Specification for Reagent Water

D2216 Test Methods for Laboratory Determination of Water (Moisture) Content of Soil and Rock by Mass

D2234/D2234M Practice for Collection of a Gross Sample of Coal

D3370 Practices for Sampling Water from Closed Conduits

D5681 Terminology for Waste and Waste Management

D5744 Test Method for Laboratory Weathering of Solid Materials Using a Humidity Cell

D6234 Test Method for Shake Extraction of Mining Waste by the Synthetic Precipitation Leaching Procedure

E122 Practice for Calculating Sample Size to Estimate, With Specified Precision, the Average for a Characteristic of a Lot or Process

E877 Practice for Sampling and Sample Preparation of Iron Ores and Related Materials for Determination of Chemical Composition and Physical Properties

E1915 Test Methods for Analysis of Metal Bearing Ores and Related Materials for Carbon, Sulfur, and Acid-Base Characteristics

E2242 Test Method for Column Percolation Extraction of Mine Rock by the Meteoric Water Mobility Procedure

3. Terminology

3.1 For definitions of terms used in this practice, see Terminology D5681.

3.2 Definitions of Terms Specific to This Standard:

3.2.1 *metal mining waste, n*—overburden or waste rock excavated and disposed of during mining operations.

² For referenced ASTM standards, visit the ASTM website, www.astm.org, or contact ASTM Customer Service at service@astm.org. For *Annual Book of ASTM Standards* volume information, refer to the standard's Document Summary page on the ASTM website.

³ The last approved version of this historical standard is referenced on www.astm.org.

3.2.2 *mineral processing waste, n*—waste generated from ore processing metallurgical operation such as tailings.

4. Significance and Use

4.1 This practice is intended as a rapid means for obtaining an extract of solid waste. The extract may be used to estimate the release of constituents of the solid waste under the laboratory conditions described in this procedure.

4.1.1 This practice is not intended to be used as a kinetic test to simulate weathering of ore, metal mining, and metallurgical processing wastes. For kinetic testing of ore, metal mining, and metallurgical processing wastes, refer to Test Method [D5744](#) to determine release rates for constituents of interest. For static testing of metal mining ore and metal mining or metallurgical processing waste materials, refer to Test Methods [E1915](#) and [D6234](#). If the conditions of this practice are not suitable for the test material, Test Method [E2242](#) may be used, if applicable to the ore or waste.

4.2 This practice is not intended to provide an extract that is representative of the actual leachate produced from a solid waste in the field, or to produce extracts to be used as the sole basis of engineering design.

4.3 This practice is not intended to simulate site-specific leaching conditions. It has not been demonstrated to simulate actual disposal site leaching conditions.

4.4 The intent of this practice is that the final pH of the extract reflects the interaction of the extractant with the buffering capacity of the solid waste.

4.5 The intent of this practice is that the water extraction simulates conditions where the solid waste is the dominant factor in determining the pH of the extract.

4.6 The practice produces an extract that is amenable to the determination of both major and minor constituents. When minor constituents are being determined, it is especially important that precautions are taken in sample storage and handling to avoid possible contamination of the samples.

4.6.1 This practice has been tested to determine its applicability to certain inorganic components in metal mining and metallurgical processing wastes.

4.7 The practice has not been tested for applicability to organic substances and volatile matter.

5. Apparatus

5.1 *Agitation Equipment*, of any type that rotates about a central axis at a rate of 29 ± 2 r/min and mixes samples in an end-over-end fashion. (See example equipment in [Fig. 1.](#))

NOTE 1—Modifications to the agitation technique (orientation or rate) could result in alteration of the degree of mixing or the rate of release of constituents, as well as causing particle abrasion. As a result, the precision of the practice may also be influenced.

5.2 *Membrane or Pressure Filter Assembly:*

5.2.1 *Membrane Filter*—A borosilicate glass or stainless steel funnel with a flat, fritted base of the same material and membrane filters.

5.2.2 *Pressure Filtration Assembly*—A pressure filtration device using pressure-regulated compressed gas of a compo-

sition suitable to the nature of the analyses to be performed and equipped with a 0.45- or 0.8- μ m pore size filter.

5.3 *Containers*, round, wide-mouth, of a composition suitable to the nature of the solid waste and the analyses to be performed, and constructed of materials that will not allow sorption of constituents of interest.

5.3.1 Containers should be of sufficient size to contain the mass of the solid sample plus the volume of extractant at a liquid-to-solid ratio of 20 mL/g, leaving approximately 10 to 20 % headspace for mixing. For example, 2-L (0.5-gal) containers may be used for 70-g (0.15-lb) samples with 1400 mL (0.37 gal) of extractant, while 4-L (1-gal) containers may be required for 140-g (0.30-lb) samples with 2800 mL (0.74 gal) of extractant.

5.3.1.1 Extraction vessels should be cleaned in a manner consistent with the analyses to be performed. (See Section 13 of Practices [D3370.](#))

5.3.2 Containers must have watertight closures.

5.3.3 Containers with venting mechanisms should be provided for samples where gases may be released.

NOTE 2—Allowing the container to vent generated gases has the potential to affect the concentrations of constituents in the extract.

5.3.4 Containers should be cleaned in a manner consistent with the analyses to be performed.

5.4 *Drying Pans or Dishes*, (for example, aluminum tins, porcelain dishes, glass weighing pans), two per waste, suitable to the waste being tested and the instructions given in [9.2.](#)

5.5 *Drying Oven*—Any thermostatically controlled drying oven capable of maintaining a steady temperature of ± 2 °C in a range of 100 to 110 °C.

5.6 *Desiccator*, having a capacity to hold the drying pans described in [5.4.](#)

5.7 *Laboratory Balance*, capable of accurately measuring 0.01 g.

5.8 *Magnetic Stir Plate.*

5.9 *pH Meter*, with temperature compensation, readability of 0.01 units and an accuracy of ± 0.05 units at 25 °C.

6. Reagents

6.1 *Purity of Reagents*—Reagent-grade chemicals shall be used. Unless otherwise indicated, it is intended that all reagents shall conform to the specifications of the American Chemical Society, where such specifications are available. Other grades may be used, provided it is first ascertained that the reagent is of sufficiently high purity to permit its use without lessening the accuracy of the determination.

6.2 *Purity of Water*—Unless otherwise indicated, references to water shall be understood to mean Type IV reagent water at 18 to 27 °C (Specification [D1193](#)). The method by which the Type IV water is prepared, that is, distillation, ion exchange, reverse osmosis, electrodialysis, should remain constant throughout testing.

7. Sampling

7.1 Obtain a representative sample of the solid waste to be tested using ASTM sample methods developed for the specific

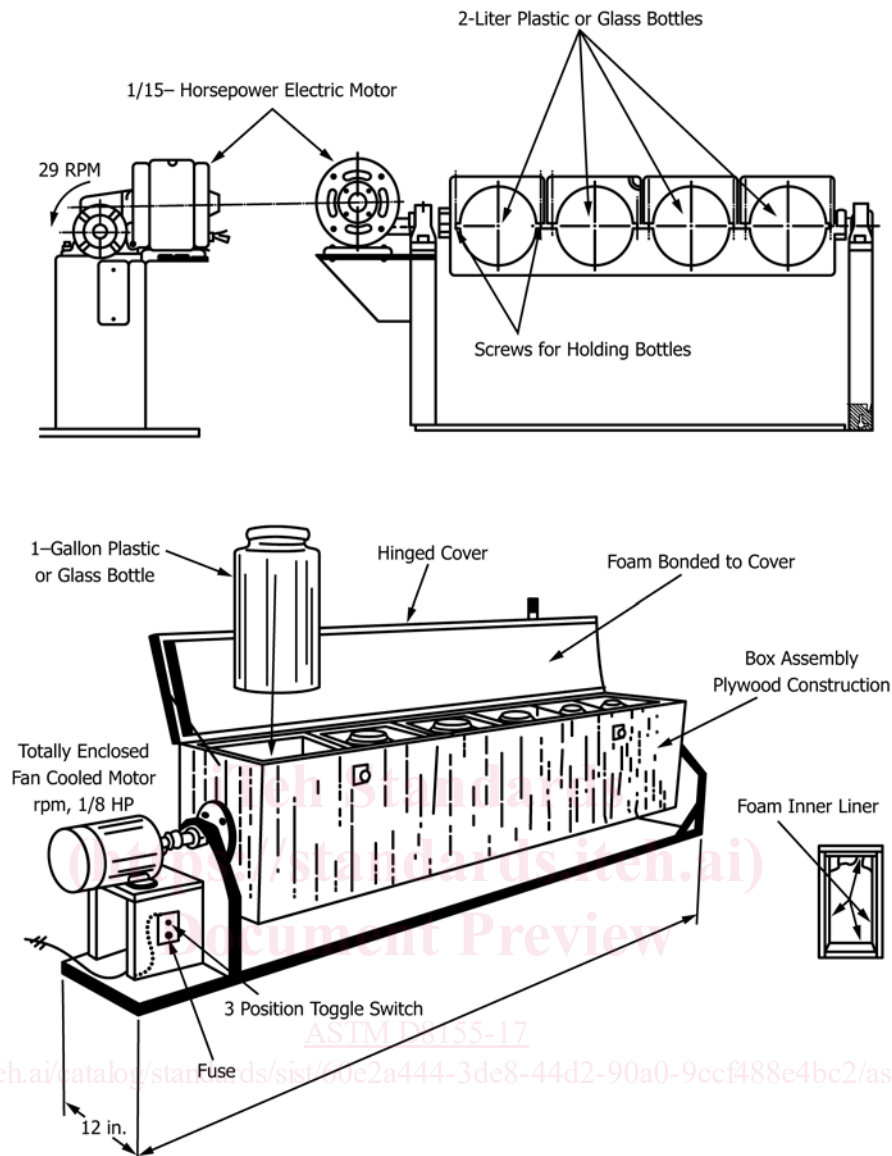

FIG. 1 Example Extractor

industry where available. (See Guide D420 and Practices D75/D75M, E877, and D2234/D2234M.)

7.2 Where no specific methods are available, sampling methodology for materials of similar physical form shall be used.

7.3 A minimum sample of 5 kg shall be sent to the laboratory (see Practice E122).

7.3.1 For metal mine and metallurgical processing wastes, the minimum amount of sample to be sent to the laboratory should be sufficient to perform the solids content determination as specified in 9.2, and to provide 100 g of sample on a dry weight basis for extraction.

7.4 It is important that the sample of the solid waste be representative with respect to surface area, as variations in surface area would directly affect the leaching characteristics of the sample. Solid waste samples should contain a representative distribution of particles sizes.

7.4.1 It is important that the sample of metal mining or metallurgical processing waste be representative with respect to the inorganic constituents to be determined.

NOTE 3—Information on obtaining representative samples can also be found in Pierre Gy's Sampling Theory and Sampling Practice.⁴

7.5 Keep samples in closed containers appropriate to the sample type prior to the extraction in order to prevent sample contamination or constituent loss. Where it is desired to extract biologically or chemically active samples in their existing state, store the samples at 4 ± 2 °C (Practices D3370) and start the extraction within 8 h. Where it is desired to extract such samples in a state representative of the results of biological or chemical activities, the samples may be specifically handled to

⁴ Pitard, F., *Pierre Gy's Sampling Theory and Sampling Practice*, 2nd Edition, CRC Press, Boca Raton, FL, 1993.