



Designation: **C1663–09 C1663 – 17**

Standard Test Method for Measuring Waste Glass or Glass Ceramic Durability by Vapor Hydration Test¹

This standard is issued under the fixed designation C1663; the number immediately following the designation indicates the year of original adoption or, in the case of revision, the year of last revision. A number in parentheses indicates the year of last reapproval. A superscript epsilon (ϵ) indicates an editorial change since the last revision or reapproval.

1. Scope

1.1 The vapor hydration test method can be used to study the corrosion of a waste forms such as glasses and glass ceramics² upon exposure to water vapor at elevated temperatures. In addition, the alteration phases that form can be used as indicators of those phases that may form under repository conditions. These tests; which allow altering of glass at high surface area to solution volume ratio; provide useful information regarding the alteration phases that are formed, the disposition of radioactive and hazardous components, and the alteration kinetics under the specific test conditions. This information may be used in performance assessment (McGrail et al, 2002 **(1)**³ for example).

1.2 This test method must be performed in accordance with all quality assurance requirements for acceptance of the data.

1.3 *This standard does not purport to address all of the safety concerns, if any, associated with its use. It is the responsibility of the user of this standard to establish appropriate ~~safety~~ safety, health, and ~~health~~ environmental practices and determine the applicability of regulatory limitations prior to use.*

1.4 *This international standard was developed in accordance with internationally recognized principles on standardization established in the Decision on Principles for the Development of International Standards, Guides and Recommendations issued by the World Trade Organization Technical Barriers to Trade (TBT) Committee.*

2. Referenced Documents

2.1 *ASTM Standards:*⁴

[C162 Terminology of Glass and Glass Products](#)

[C859 Terminology Relating to Nuclear Materials](#)

[D1125 Test Methods for Electrical Conductivity and Resistivity of Water](#)

[D1193 Specification for Reagent Water](#)

[D1293 Test Methods for pH of Water](#)

[E177 Practice for Use of the Terms Precision and Bias in ASTM Test Methods](#)

[E691 Practice for Conducting an Interlaboratory Study to Determine the Precision of a Test Method](#)

3. Terminology

3.1 Please refer to Terminologies [C162](#) and [C859](#) for additional terminology which may not be listed below.

3.2 *Definitions:*

3.1.1 *alteration layer*—a layer of alteration products at the surface of specimen. Several distinct layers may form at the surface and within cracks in the glass. Layers may be comprised of discrete crystallites. The thickness of these layers may be used to estimate the amount of glass altered.

3.1.2 *alteration products*—crystalline or amorphous phases formed as a result of glass interaction with an aqueous environment by precipitation from solution or by in situ transformation of the chemically altered solid.

¹ This test method is under the jurisdiction of ASTM Committee [C26](#) on Nuclear Fuel Cycle and is the direct responsibility of Subcommittee [C26.13](#) on Spent Fuel and High Level Waste.

Current edition approved June 1, 2009 Nov. 1, 2017. Published July 2009 December 2017. Originally approved in 2009. Last previous edition approved in 2009 as C1663 – 09. DOI: [10.1520/C1663-09.10.1520/C1663-17](#).

² The precision and bias statements are only valid for glass waste forms at this time. The test may be (and has been) performed on other waste forms; however, the precision of such tests are currently unknown.

³ The boldface numbers in parentheses refer to the list of references at the end of this standard.

⁴ For referenced ASTM standards, visit the ASTM website, [www.astm.org](#), or contact ASTM Customer Service at [service@astm.org](#). For *Annual Book of ASTM Standards* volume information, refer to the standard's Document Summary page on the ASTM website.

3.1.3 *glass*—an inorganic product of fusion that has cooled to a rigid condition without crystallizing. **C162**

3.1.4 *glass ceramic*—solid material, partly crystalline and partly glassy, formed by the controlled crystallization of a glass. **C162**

3.1.5 *glass transition temperature*—on heating, the temperature at which a glass transforms from an elastic to a viscoelastic material, characterized by the onset of a rapid change in thermal expansivity. **C162**

3.2.1 *immobilized low-activity waste*—vitrified low-activity fraction of waste presently contained in Hanford Site tanks.

3.2.2 *performance assessment*—examines the long-term environmental and human health effects associated with the planned disposal of waste. **Mann et al, 2001 (2)**

3.2.3 *sample*—initial test material with known composition.

3.2.4 *specimen*—specimen is a part of the sample used for testing.

3.2.5 *traceable standard*—a material that supplies a link to known test response in standards international units by a national or international standards body, for example, NIST.

3.3 *Abbreviations:*

3.3.1 *DIW*—ASTM Type I deionized water

3.3.2 *EDS*—energy dispersive X-ray spectroscopy

3.3.3 *OM*—optical microscopy

3.3.4 *OM/IA*—optical microscope connected to an image analysis system

3.3.5 *PTFE*—polytetrafluoroethylene (chemical compound commonly referred to as Teflon)

3.3.6 *SEM*—scanning electron microscope

3.3.7 *SiC paper*—silicon-carbide paper

3.3.8 *TBD*—to be determined

3.3.9 *TEM*—transmission electron microscope

3.3.10 T_g —glass transition temperature

3.3.11 *VHT*—vapor hydration test

3.3.12 *WDS*—wave-length dispersive spectroscopy

3.3.13 *XRD*—X-ray diffraction

3.3.14 *%RSD*—percent relative standard deviation

4. Summary of Test Method

4.1 For the vapor hydration tests, glass or glass ceramic specimens (referred to generally as glass samples in this test method) are suspended from a support rod inside the test vessel with platinum wire. A volume of water determined by the volume of the test vessel and the test temperature is added to the vessel. The vessel is then sealed and placed in an oven at the desired test temperature and left undisturbed. After the desired test duration, the vessel is removed from the oven and the bottom of the vessel is cooled to condense the vapor in the vessel. Specimens are removed and examined with optical microscopy, XRD, SEM, and other analytical methods. The remaining glass or glass ceramic thickness is measured and alteration phases are identified.

5. Significance and Use

5.1 The vapor hydration test can be used to study the corrosion of glass and glass ceramic waste forms under conditions of high temperature and contact by water vapor or thin films of water. This method may serve as an accelerated test for some materials, since the high temperatures will accelerate thermally activated processes. A wide range of test temperatures have been reported in the literature -40°C (Ebert et al, 2005 (3), for example) to 300°C (Vienna et al, 2001 (4), for example). It should be noted that with increased test temperature comes the possibility of changing the corrosion rate determining mechanism and the types of phases formed upon alteration from those that occur in the disposal environment (Vienna et al, 2001 (4)).

5.2 The vapor hydration test can be used as a screening test to determine the propensity of waste forms to alter and for relative comparisons in alteration rates between waste forms.

6. Apparatus

6.1 *Test Vessels*—Stainless steel vessels with closure fitting with unique identifiers (on both vessel and lid), (for example, 22 mL vessels, rated for service at temperatures up to 300°C and maximum pressure 11.7 MPa (1700 psi)).⁵

6.2 *Balance(s)*—Any calibrated two-point (0.00 grams) balance.

⁵ Series 4701-144704 22 mL and 4714 45 mL "A" Socket Vessels from Parr Instrument Co., 211 53rd St., Moline, IL 61265, have been found satisfactory.

6.3 *Convection Oven*—Constant temperature convection oven with the ability to control the temperature within $\pm 2^{\circ}\text{C}$.

6.4 *Temperature Monitoring Device*—Resistance thermometers or thermocouples, or both, with a strip chart recorder or a data logger for periodic monitoring of the temperature of the convection oven during the test duration. It is recommended that the maximum period between recorded temperature measurements be 0.5 h.

6.5 *Pipettes*—Calibrated pipettes. Pipette tips that have been ~~pre-cleaned~~, pre-cleaned, sterilized, or individually packaged to avoid contamination from handling.

6.6 *Torque Wrench*—Torque wrench capable of torques up to ~~230~~23.0 N·m (~~170 lbf·ft~~)(17.0 ft·lb).

6.7 *Vessel Holder*—Appropriate device/stand for holding vessels during tightening/loosening processes.

6.8 *Diamond Impregnated Saw*—High or low density diamond-coated wafering blade and low speed saw.

6.9 *Polishing Equipment*—Polishing equipment capable of polishing to 600 ~~grit~~grit (30 μm).

6.10 *Calipers*—Calipers that have been calibrated with traceable standards.

6.11 *Optical Microscope with Image Analysis System*.

6.12 *Chemically Inert Wire*—Wire used to suspend the specimens (such as 0.25 mm Pt wire).

6.13 *Support Rods*—Typically 1.5 mm diameter 304L stainless steel (or comparable material) rods bent to the shape shown in Fig. 2. Used to suspend specimens within the pressure vessel during tests.

6.14 *Non-Combustible Tray*—For water to quench vessel bottom after test termination.

6.15 *Storage Vessels*—Polyethylene or glass vessels for specimen storage.

6.16 *Ultrasonic Bath*.

6.17 *pH Paper*.

6.18 *SiC Paper*.

6.19 *Non-Talc Surgical Gloves*.

6.20 *Glass Slides*.

6.21 *PTFE Tape*—The type commonly used for household plumbing.

6.22 *Tweezers/Forceps*.

6.23 *Scissors*.

6.24 *Glue or Thermoplastic Adhesive*, for attaching samples and specimen to glass slides (for example, crystal-bond, super-glue, or wax).

6.25 *pH Probe*, calibrated with traceable standards.

7. Reagents and Standards

7.1 *ASTM Type I Water*—Type I water shall have a minimal electrical resistivity of 18.0 M Ω ·cm at 25°C (see Specification **D1193**).

7.2 *Solvents*—Absolute ethanol and reagent grade acetone.

7.3 *Reagent Grade HNO₃*—6 M HNO₃ and ~~0.16M~~0.16 M HNO₃.

8. Hazards

8.1 All appropriate precautions for operation of pressurized equipment must be taken. To ensure safe operation, the test vessels should be rated to withstand the vapor pressure of water at the test temperature with an appropriate safety factor.

9. Specimen Preparation

9.1 Glass or glass ceramic specimens are prepared from annealed bars (for example, anneal 2 hours at a temperature slightly above the glass transition temperature with subsequent slow cooling to room temperature inside the oven, care must be taken not to induce phase changes during ~~annealing~~ using annealing). Annealed bars are cut with a diamond impregnated saw and SiC papers with different grits.⁶ During the specimen preparation, it is important to use low cutting force and saw speed (dependent on sample). Rough surface and damaged edges of the samples indicate rough machining. This may cause cracks to form within the glass or glass ceramic specimen during the sample preparation and decrease the reproducibility of the test. Preparation of the specimen may vary according to the equipment used. Usually specimens are prepared slightly larger and subsequently polished

⁶ For detailed discussion of the influence of surface finish on corrosion see Mendel et al, 1984 (5). Some example results of vapor hydration tests with varying surface finish are reported in Jiricka et al, 2001 (6).

to the desired dimensions. However, with certain types of diamond impregnated saws, it is possible to prepare specimens with the desired dimensions and polish the surface directly with 600 grit SiC paper. The details of one example of preparation technique are given below. These steps (9.1.1 – 9.1.49-1.5) are only given as an example and can be adjusted to yield the desired specimen dimensions and surface finish.

9.1.1 Cut annealed glass or glass ceramic bars with a diamond-impregnated saw to roughly the dimensions 10.3 by 10.3 by 30–501.6 mm (with appropriate cooling fluid). For certain samples, such as glass ceramic materials, water should be avoided in order to not dissolve the soluble phase.

9.1.2 Slice from the square glass or glass ceramic bar using a diamond-impregnated saw a roughly 1.6 mm-thick specimen (10.3 by 10.3 by 1.6 mm) (with appropriate cooling fluid):

9.1.2 Polish to roughly the dimensions 10.2 by 10.2 by 1.55 mm using 240 grit SiC (with appropriate cooling fluid).

9.1.3 Polish to roughly the dimensions 10.1 by 10.1 by 1.51 mm using 400 grit SiC (with appropriate cooling fluid).

9.1.4 Polish to the dimensions 10.0 by 10.0 by 1.50 mm using 600 grit SiC paper (with appropriate cooling fluid).

9.2 Ultrasonically clean specimen in ethanol for 2 min, decant, and discard ethanol.

9.3 Ultrasonically clean specimen in ethanol for 4 min, decant, and discard ethanol.

9.4 Dry specimen in an oven at 90°C for 15 min.

9.5 Examine each specimen with OM and record observations concerning specimen surface and heterogeneity (streaks, inclusions, and scratches).

10. Test Vessel Cleaning

10.1 *Cleaning of Stainless Steel Vessels and Support Rods:*

10.1.1 Degrease vessels and lids with acetone. (This step is performed only with new vessels.)

10.1.2 Use 400 grit SiC paper to remove debris and oxidation from inside parts of previously used vessels and rinse with DIW.

10.1.3 Ultrasonically clean vessels, lids, and stainless steel supports in ethanol for 5 min, decant and discard ethanol.

10.1.4 Rinse vessels, lids, and supports by immersing 3 times in fresh DIW.

10.1.5 Soak vessels, lids, and supports in reagent grade 0.16M–0.16 M HNO₃ at 90°C for 1 h.

10.1.6 Rinse vessels, lids, and supports by immersing 3 times in fresh DIW.

10.1.7 Soak vessels, lids, and supports in fresh DIW at 90°C for 1 h.

10.1.8 Rinse vessels, lids, and supports by immersing in fresh DIW.

10.1.9 Fill vessels (with supports placed inside) to 80–90 % of capacity with fresh DIW. Place lids on vessels. Do not tighten. Place them in an oven at 90°C for a minimum of 16 h.

10.1.10 After cooling, measure the pH of the DIW using the pH probe according to Test Methods D1293. If the pH value is not within the 5.0 to 7.0 range, repeat rinsing from step 10.1.6.

10.1.11 Dry vessels, lids, and supports in an oven at 90°C for at least 1 h.

10.1.12 Store vessels, lids, and supports in a clean, dry, environment until use.

10.2 *Cleaning of PTFE Gaskets:*

NOTE 1—Other gasket materials may be used, so long as they do not significantly impact the reactions between water and the sample. This may be an important consideration in high radiation environments.

10.2.1 Bake PTFE gaskets for 1 week at 200°C. (This step is performed only with new PTFE gaskets.)

10.2.2 Soak the gaskets in reagent grade 6 M HNO₃ at 50 ± 5°C for 4 h.

10.2.3 Rinse the gaskets by immersing in fresh DIW 3 times.

10.2.4 Immerse the gaskets in fresh DIW and boil for 30 min.

10.2.5 Rinse by immersing the gaskets in fresh DIW.

10.2.6 Soak the gaskets for 8 h in fresh DIW at 80°C.

10.2.7 Rinse the gaskets by immersing in fresh DIW.

10.2.8 Immerse the gaskets in fresh DIW and boil for 30 min.

10.2.9 Rinse the gaskets by immersing 3 times in fresh DIW (container with gaskets is filled 3 times with fresh DIW).

10.2.10 Submerge gaskets in fresh DIW. Measure pH using the pH probe according to Test Methods D1293. If the pH value is not within the 5.0 to 7.0 range, repeat step 10.2.9.

10.2.11 Dry gaskets in an oven at 90°C and store in a clean environment until needed.

11. Calibration

11.1 *Calibrations*—Initially calibrate all measurement instruments used in this test. Verify the calibrations during use of the instrument to indicate possible errors due to instrumental drift.

11.2 *Calibration and Standardization Schedule:*

11.2.1 *Temperature Measurement Devices*—Calibrate at least annually with traceable standards or an ice/boiling water bath.

11.2.2 *Balance*—Standardize with traceable standard masses on a regular basis. If a deviation in mass measurement is identified, all measurements since the last accurate standard measurement made with the balance must be marked appropriately. Have balance calibrated on an annual basis.

11.2.3 *Water Purification System*—Calibrate at least annually following the manufacturer’s instructions. Standardize with the 10 MΩ·cm at 25°C resistivity calibration cell (or equivalent) on the water purification system (see Test Methods D1125).

11.2.4 *Calipers*—Calibrate with traceable standards at least annually.

11.2.5 *Image Analysis System*—Calibrate with a micrometric calibration ruler designed for image analysis calibration.

12. Procedure for Conducting the Vapor Hydration Test

12.1 *Amount of Water Needed*—In order to conduct reliable VHTs, the amount of water added to the vessel must be sufficient to saturate the vessel’s volume at the test temperature and provide excess water that can condense on the test specimen surface without sufficient water to reflux during testing. The amount of water needed for saturating a 22 mL vessel was calculated assuming ideal conditions, H₂O, N₂, and O₂. It consists of an amount of water needed to saturate the vessel at a given temperature (determined from steam tables) plus an additional 0.05 mL of excess water needed for each specimen with dimensions of 10.0 by 10.0 by 1.5 mm (surface area 260 mm²). The volume of the specimen assembly (specimen, support rod, and chemically inert wire) was not accounted for in steam saturation calculations. Similar calculations should be performed if using vessels with different volumes.

12.2 *Test Set-Up:*

12.2.1 Verify that the convection oven is at the desired temperature and temperature-monitoring device has been calibrated.

12.2.2 Verify that the stainless steel test vessels have been cleaned according to Section 10. The vessels must have a unique number permanently affixed to the vessel cap and bottom.

12.2.3 Wind the threads of the vessel closure fittings with PTFE tape to prevent binding of the closure threads (roughly 2 wraps).

12.2.4 Verify that a calibrated balance accurate to ±0.01 g is available.

12.2.5 Verify that a pipette and fresh DIW are available.

12.2.6 Verify that a torque wrench is available and set to the desired setting between 20320.3 N·m and 23023.0 N·m (150 lbf·ft to 170 lbf·ft) (15.0 ft·lb to 17.0 ft·lb).

12.2.7 Verify that the stainless steel support rods have been cleaned and thoroughly rinsed with ethanol according to Section 10.

12.2.8 Verify that the required data sheet and test parameters for the VHT are available, see Appendix X1 for an example data sheet.

12.2.9 Verify that the test specimens are prepared according to Section 9.

12.3 *Test Start-Up Procedure:*

12.3.1 Record the following information on a VHT Data Sheet: (1) Test number, (2) Test temperature, (3) Planned test duration, (4) Vessel and cap identification number, and (5) Sample/specimen identification.

12.3.2 Wear non-talc gloves (or equivalent covering if in remote environment) and use tweezers when tying the specimen as shown in Fig. 1.

12.3.3 Place the support with specimen in proper position inside the assigned vessel as shown in Fig. 2.

12.3.4 Place a clean PTFE gasket (or equivalent) inside a vessel cap.

NOTE 2—The PTFE gasket should be replaced by a different material in those cases where high radiation fields and long test times are expected to introduce sufficient fluorine onto the test specimen to influence test result.

12.3.5 Place vessel bottom, cap and vessel closure (not assembled) on a balance accurate to ±0.01 g and record the mass.

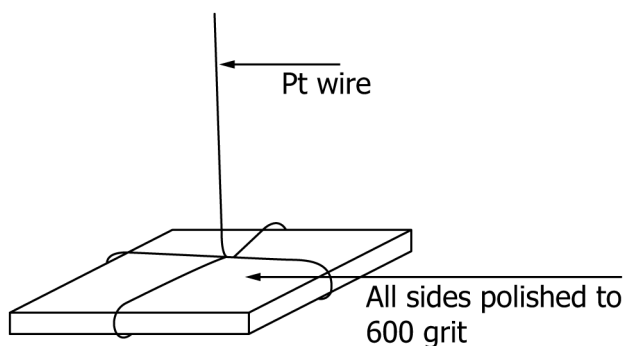

FIG. 1 Glass Specimen Suspended with Thin Pt Wire (roughly 0.2 mm diameter)

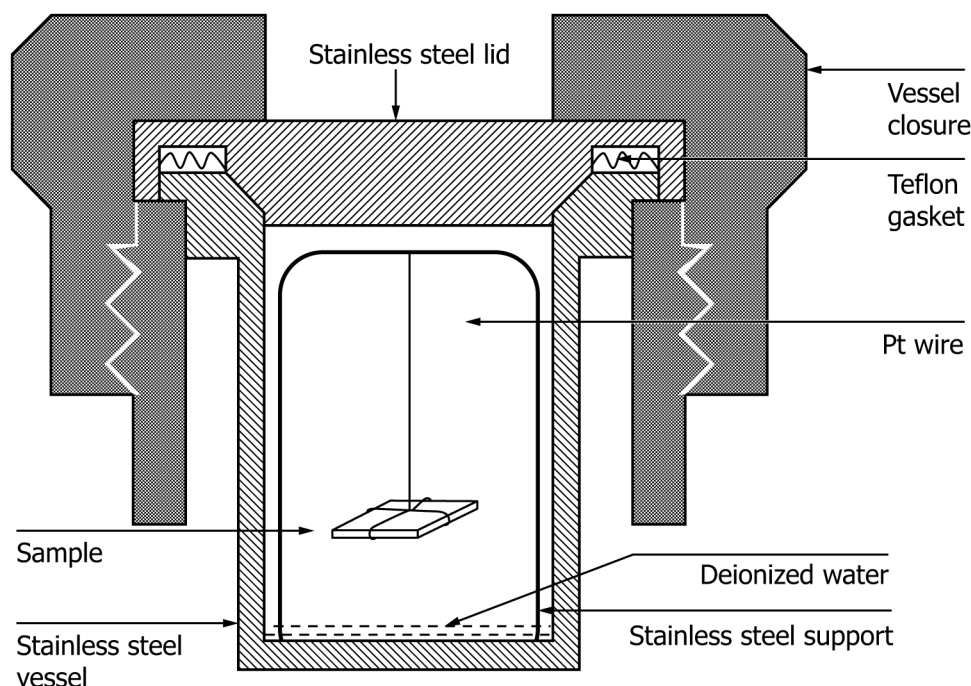

FIG. 2 Apparatus for Conducting Vapor Hydration Tests

12.3.6 Using a pipette, add the targeted amount (in mL) of fresh DIW (see [Table 1](#) as example for 22 mL vessel with one sample) to the vessel and record the mass. Verify that the amount of water added is the difference between dry assembly and assembly including water.

12.3.7 Place the assembly in an appropriate device/stand for holding vessels during tightening and tighten with torque wrench to between $20320.3 \text{ N}\cdot\text{m}$ and $23023.0 \text{ N}\cdot\text{m}$ ($150 \text{ lbf}\cdot\text{ft}$ to $170 \text{ lbf}\cdot\text{ft}$) ($15.0 \text{ ft}\cdot\text{lb}$ to $17.0 \text{ ft}\cdot\text{lb}$).

12.3.8 Record the oven temperature and calibration status of the temperature monitoring device on the data sheet.

12.3.9 Place the test vessel inside the oven and record the time and date on the data sheet.

12.4 During Test:

ASTM C1663-17

<https://standards.iteh.ai/catalog/standards/sist/3094691a-08d8-48fb-935b-bab038c0f54e/astm-c1663-17>

TABLE 1 Vapor Pressure and Amounts of Water Needed for the VHT with 22 mL Vessels for Temperatures from 5°C to 300°C

NOTE 1—The table should be used as a guide to determine the mass of water necessary to perform a test.

T [°C]	P [MPa] ^A	H ₂ O [g]	T [°C]	P [MPa] ^A	H ₂ O [g]
5	6.1E-04	0.05	110	1.4E-01	0.07
10	8.8E-04	0.05	115	1.7E-01	0.07
15	1.2E-03	0.05	120	2.0E-01	0.08
20	1.7E-03	0.05	125	2.3E-01	0.08
25	2.4E-03	0.05	130	2.7E-01	0.09
30	3.2E-03	0.05	140	3.6E-01	0.10
35	4.3E-03	0.05	150	4.8E-01	0.11
40	5.7E-03	0.05	160	6.2E-01	0.13
45	7.4E-03	0.05	170	8.0E-01	0.15
50	9.6E-03	0.05	180	1.0E+00	0.18
55	1.2E-02	0.05	190	1.3E+00	0.21
60	1.6E-02	0.05	200	1.6E+00	0.25
65	2.0E-02	0.05	210	1.9E+00	0.29
70	2.5E-02	0.05	220	2.3E+00	0.35
75	3.1E-02	0.06	230	2.8E+00	0.42
80	3.9E-02	0.06	240	3.4E+00	0.49
85	4.8E-02	0.06	250	4.0E+00	0.59
90	5.8E-02	0.06	260	4.7E+00	0.70
95	7.0E-02	0.06	270	5.5E+00	0.83
100	8.5E-02	0.06	280	6.4E+00	0.98
105	1.0E-01	0.07	300	7.5E+00	1.39

^ANBS/NRS Steam Tables,[®] Lester Haar et al, Hemisphere Publishing Corp., 1984, pp. 9–14.