



# Standard Test Method for Cloud Point of Petroleum Products and Liquid Fuels<sup>1</sup>

This standard is issued under the fixed designation D2500; the number immediately following the designation indicates the year of original adoption or, in the case of revision, the year of last revision. A number in parentheses indicates the year of last reapproval. A superscript epsilon ( $\epsilon$ ) indicates an editorial change since the last revision or reapproval.

*This standard has been approved for use by agencies of the U.S. Department of Defense.*

## 1. Scope\*

1.1 This test method covers only petroleum products and biodiesel fuels that are transparent in layers 40 mm in thickness, and with a cloud point below 49 °C.

NOTE 1—The interlaboratory program consisted of petroleum products of Test Method D1500 color of 3.5 and lower. The precisions stated in this test method may not apply to samples with ASTM color higher than 3.5.

1.2 The values stated in SI units are to be regarded as standard. No other units of measurement are included in this standard.

1.3 **WARNING**—Mercury has been designated by many regulatory agencies as a hazardous material that can cause central nervous system, kidney and liver damage. Mercury, or its vapor, may be hazardous to health and corrosive to materials. Caution should be taken when handling mercury and mercury containing products. See the applicable product Material Safety Data Sheet (MSDS) for details and EPA's website—<http://www.epa.gov/mercury/faq.htm>—for additional information. Users should be aware that selling mercury and/or mercury containing products into your state or country may be prohibited by law.

1.4 *This standard does not purport to address all of the safety concerns, if any, associated with its use. It is the responsibility of the user of this standard to establish appropriate safety, health, and environmental practices and determine the applicability of regulatory limitations prior to use.* For specific hazard statements, see Section 7.

1.5 *This international standard was developed in accordance with internationally recognized principles on standardization established in the Decision on Principles for the Development of International Standards, Guides and Recommendations issued by the World Trade Organization Technical Barriers to Trade (TBT) Committee.*

<sup>1</sup> This test method is under the jurisdiction of ASTM Committee D02 on Petroleum Products, Liquid Fuels, and Lubricants and is the direct responsibility of Subcommittee D02.07 on Flow Properties.

Current edition approved Dec. 1, 2017. Published January 2018. Originally approved in 1966. Last previous edition approved in 2017 as D2500 – 17. DOI: 10.1520/D2500-17A.

## 2. Referenced Documents

### 2.1 ASTM Standards:<sup>2</sup>

D1500 Test Method for ASTM Color of Petroleum Products (ASTM Color Scale)

D6300 Practice for Determination of Precision and Bias Data for Use in Test Methods for Petroleum Products and Lubricants

D7962 Practice for Determination of Minimum Immersion Depth and Assessment of Temperature Sensor Measurement Drift

E1 Specification for ASTM Liquid-in-Glass Thermometers

E644 Test Methods for Testing Industrial Resistance Thermometers

E2251 Specification for Liquid-in-Glass ASTM Thermometers with Low-Hazard Precision Liquids

E2877 Guide for Digital Contact Thermometers

### 2.2 Energy Institute Standard:<sup>3</sup>

Specifications for IP Standard Thermometers

## 3. Terminology

### 3.1 Definitions:

3.1.1 *digital contact thermometer (DCT), n*—an electronic device consisting of a digital display and associated temperature sensing probe.

3.1.1.1 *Discussion*—This device consists of a temperature sensor connected to a measuring instrument; this instrument measures the temperature-dependent quantity of the sensor, computes the temperature from the measured quantity, and provides a digital output. This digital output goes to a digital display and/or recording device that may be internal or external to the device. These devices are referred to as “digital thermometers.”

3.1.1.2 *Discussion*—PET is an acronym for portable electronic thermometers, a subset of digital contact thermometers (DCT).

<sup>2</sup> For referenced ASTM standards, visit the ASTM website, [www.astm.org](http://www.astm.org), or contact ASTM Customer Service at [service@astm.org](mailto:service@astm.org). For *Annual Book of ASTM Standards* volume information, refer to the standard's Document Summary page on the ASTM website.

<sup>3</sup> Available from Energy Institute, 61 New Cavendish St., London, WIG 7AR, U.K., <http://www.energyinst.org.uk>.

\*A Summary of Changes section appears at the end of this standard

3.2 Definitions of Terms Specific to This Standard:

3.2.1 *biodiesel, n*—a fuel comprised of mono-alkyl esters of long chain fatty acids derived from vegetable oils or animal fats, designated B100.

3.2.1.1 *Discussion*—Biodiesel is typically produced by a reaction of vegetable oil or animal fat with an alcohol such as methanol or ethanol in the presence of a catalyst to yield mono-esters and glycerin. The fuel typically may contain up to 14 different types of fatty acids that are chemically transformed into fatty acid methyl esters (FAME).

3.2.2 *biodiesel blend, n*—a blend of biodiesel fuel with petroleum-based diesel fuel designated BXX, where XX is the volume % of biodiesel.

3.2.3 *cloud point, n*—in petroleum products and biodiesel fuels, the temperature of a liquid specimen when the smallest observable cluster of wax crystals first occurs upon cooling under prescribed conditions.

3.2.3.1 *Discussion*—To many observers, the cluster of wax crystals looks like a patch of whitish or milky cloud, hence the name of the test method. The cloud appears when the temperature of the specimen is low enough to cause wax crystals to form. For many specimens, the crystals first form at the lower circumferential wall of the test jar where the temperature is lowest. The size and position of the cloud or cluster at the cloud point varies depending on the nature of the specimen. Some samples will form large, easily observable, clusters, while others are barely perceptible.

3.2.3.2 *Discussion*—Upon cooling to temperatures lower than the cloud point, clusters of crystals will grow in multiple directions; for example, around the lower circumference of the test jar, towards the center of the jar, or vertically upwards. The crystals can develop into a ring of cloud along the bottom circumference, followed by extensive crystallization across the bottom of the test jar as temperature decreases. Nevertheless, the cloud point is defined as the temperature at which the crystals first appear, not when an entire ring or full layer of wax has been formed at the bottom of the test jar.

3.2.3.3 *Discussion*—In general, it is easier to detect the cloud point of samples with large clusters that form quickly, such as paraffinic samples. The contrast between the opacity of the cluster and the liquid is also sharper. In addition, small brightly-reflective spots can sometimes be observed inside the cluster when the specimen is well illuminated. For other more difficult samples, such as naphthenic, hydrocracked, and those samples whose cold flow behavior have been chemically altered, the appearance of the first cloud can be less distinct. The rate of crystal growth is slow, the opacity contrast is weak, and the boundary of the cluster is more diffuse. As the temperature of these specimens decrease below the cloud point, the diffuse cluster will increase in size and can form a general haze throughout. A slight haze throughout the entire sample, which slowly becomes more apparent as the temperature of the specimen decreases, can also be caused by traces of water in the specimen instead of crystal formation (see Note 6). With these difficult samples, drying the sample prior to testing can eliminate this type of interference.

3.2.3.4 *Discussion*—The purpose of the cloud point method is to detect the presence of the wax crystals in the specimen;

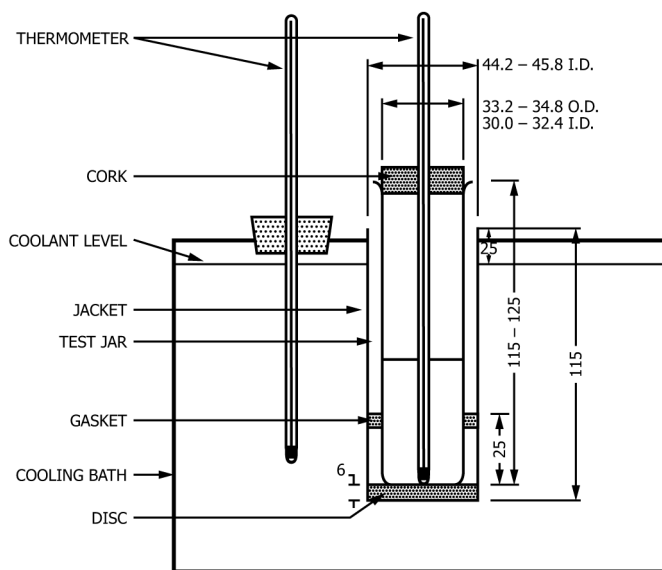

NOTE 1—All dimensions are in millimetres.

FIG. 1 Apparatus for Cloud Point Test

however trace amounts of water and inorganic compounds may also be present. The intent of the cloud point method is to capture the temperature at which the liquids in the specimen begin to change from a single liquid phase to a two-phase system containing solid and liquid. It is not the intent of this test method to monitor the phase transition of the trace components, such as water.

4. Summary of Test Method

4.1 The specimen is cooled at a specified rate and examined periodically. The temperature at which a cloud is first observed at the bottom of the test jar is recorded as the cloud point.

5. Significance and Use

5.1 For petroleum products and biodiesel fuels, cloud point of a petroleum product is an index of the lowest temperature of their utility for certain applications.

6. Apparatus (see Fig. 1)

6.1 *Test Jar*, clear, cylindrical glass, flat bottom, 33.2 mm to 34.8 mm outside diameter and 115 mm to 125 mm in height. The inside diameter of the jar may range from 30 mm to 32.4 mm within the constraint that the wall thickness be no greater than 1.6 mm. The jar should be marked with a line to indicate sample height 54 mm ± 3 mm above the inside bottom.

6.2 *Temperature Measuring Device*—Either liquid-in-glass thermometers as described in 6.2.1 or digital contact thermometer (DCT) meeting the requirements described in 6.2.2.

**TABLE 1 Cooling Mixtures and Bath Temperatures**

	Bath Temperature
Ice and water	0 °C ± 1.5 °C
Crushed ice and sodium chloride crystals, or Acetone or petroleum naphtha or methanol or ethanol (see Section 7) with solid carbon dioxide added to give the desired temperature	-18 °C ± 1.5 °C
Acetone or petroleum naphtha or methanol or ethanol (see Section 7) with solid carbon dioxide added to give the desired temperature	-33 °C ± 1.5 °C
Acetone or petroleum naphtha or methanol or ethanol (see Section 7) with solid carbon dioxide added to give the desired temperature	-51 °C ± 1.5 °C
Acetone or petroleum naphtha or methanol or ethanol (see Section 7) with solid carbon dioxide added to give the desired temperature	-69 °C ± 1.5 °C

6.2.1 *Liquid-in-Glass Thermometers*, having ranges shown below and conforming to the requirements as prescribed in Specifications E1 or E2251, or Specifications for IP Standard Thermometers.

Thermometer	Temperature Range	Thermometer Number	
		ASTM	IP
High cloud and pour	-38 °C to +50 °C	5C, S5C	1C
Low cloud and pour	-80 °C to +20 °C	6C	2C

#### 6.2.2 Digital Contact Thermometer Requirements:<sup>4</sup>

Parameter	Requirement
DCT	Guide E2877 Class F or better
Nominal Temperature range <sup>A</sup>	High Cloud: -38 °C to +50 °C Low Cloud: -80 °C to +20 °C
Display resolution	0.1 °C minimum
Accuracy <sup>B</sup>	±500 mK (±0.5 °C)
Sensor type	Platinum Resistance Thermometer (PRT), thermistor
Sensor sheath <sup>C</sup>	4.2 mm O.D. maximum
Sensor length <sup>D</sup>	Less than 10 mm
Immersion depth <sup>E</sup>	Less than 40 mm per Practice D7962
Sample immersion depth	As shown in Fig. 1 or subsection 8.3
Measurement Drift <sup>F</sup>	less than 500 mK (0.5 °C) per year
Response time <sup>F</sup>	less than or equal to 4 s per Footnote F
Calibration error	less than 500 mK (0.5 °C) over the range of intended use.
Calibration range	Consistent with temperature range of use
Calibration data	Four data points evenly distributed over the calibration range that is consistent with the range of use. The calibration data is to be included in calibration report.
Calibration report	From a calibration laboratory with demonstrated competency in temperature calibration which is traceable to a national calibration laboratory or metrology standards body

<sup>A</sup>The nominal temperature range may be different from the values shown provided the calibration and accuracy criteria are met.

<sup>B</sup>Accuracy is the combined accuracy of the DCT unit which is the display and sensor.

<sup>C</sup>Sensor sheath is the tube that holds the sensing element. The value is the outside diameter of the sheath segment containing the sensor element.

<sup>D</sup>The physical length of the temperature sensing element.

<sup>E</sup>As determined by Practice D7962 or an equivalent procedure.

<sup>F</sup>Response Time—The time for a DCT to respond to a step change in temperature. The response time is 63.2 % of the step change time as determined per Section 9 of Test Method E644. The step change evaluation begins at 20 °C ± 5 °C air to 77 °C ± 5 °C with water circulating at 0.9 m/s ± 0.09 m/s past the sensor.

NOTE 2—When making measurements below -40 °C with a PRT, it may be necessary to use a 1000 ohm sensor in order to obtain accurate measurements.

<sup>4</sup> Supporting data have been filed at ASTM International Headquarters and may be obtained by requesting Research Report RR:D02-1849. Contact ASTM Customer Service at service@astm.org.

NOTE 3—When the DCT display is mounted on the end to the probe's sheath, the test jar with the probe inserted will be unstable. To resolve this, it is recommended that the probe be less than 30 cm in length but no less than 15 cm. A 5 cm long stopper that has a low thermal conductivity, with approximately half of it inserted in the sample tube, will improve stability.

6.2.2.1 The DCT calibration drift shall be checked at least annually by either measuring the ice point or against a reference thermometer in a constant temperature bath at the prescribed immersion depth to ensure compliance with 6.2.2. See Practice D7962.

NOTE 4—When a DCT's calibration drifts in one direction over several calibration checks, it may be an indication of deterioration of the DCT.

6.3 *Cork*, to fit the test jar, bored centrally for the test thermometer.

6.4 *Jacket*, metal or glass, watertight, cylindrical, flat bottom, about 115 mm in depth, with an inside diameter of 44.2 mm to 45.8 mm. It shall be supported free of excessive vibration and firmly in a vertical position in the cooling bath of 6.7 so that not more than 25 mm projects out of the cooling medium and shall be capable of being cleaned.

6.5 *Disk*, cork or felt, 6 mm thick to fit loosely inside the jacket.

6.6 *Gasket*, ring form, about 5 mm in thickness, to fit snugly around the outside of the test jar and loosely inside the jacket. The gasket may be made of rubber, leather, or other material that is elastic enough to cling to the test jar and hard enough to hold its shape. Its purpose is to prevent the test jar from touching the jacket.

6.7 *Bath or Baths*, maintained at prescribed temperatures with a firm support to hold the jacket vertical. The required bath temperatures may be maintained by refrigeration if available, otherwise by suitable cooling mixtures. Cooling mixtures commonly used for bath temperatures shown are in Table 1.

## 7. Reagents and Materials

7.1 *Acetone*—Technical grade acetone is suitable for the cooling bath, provided it does not leave a residue on drying. (**Warning**—Extremely flammable.)

7.2 *Carbon Dioxide (Solid) or Dry Ice*—A commercial grade of dry ice is suitable for use in the cooling bath.