



Designation: C1211 – 18

# Standard Test Method for Flexural Strength of Advanced Ceramics at Elevated Temperatures<sup>1</sup>

This standard is issued under the fixed designation C1211; the number immediately following the designation indicates the year of original adoption or, in the case of revision, the year of last revision. A number in parentheses indicates the year of last reapproval. A superscript epsilon ( $\epsilon$ ) indicates an editorial change since the last revision or reapproval.

## 1. Scope

1.1 This test method covers determination of the flexural strength of advanced ceramics at elevated temperatures.<sup>2</sup> Four-point- $\frac{1}{4}$ -point and three-point loadings with prescribed spans are the standard as shown in Fig. 1. Rectangular specimens of prescribed cross-section are used with specified features in prescribed specimen-fixture combinations. Test specimens may be 3 by 4 by 45 to 50 mm in size that are tested on 40-mm outer span four-point or three-point fixtures. Alternatively, test specimens and fixture spans half or twice these sizes may be used. The test method permits testing of machined or as-fired test specimens. Several options for machining preparation are included: application matched machining, customary procedures, or a specified standard procedure. This test method describes the apparatus, specimen requirements, test procedure, calculations, and reporting requirements. The test method is applicable to monolithic or particulate- or whisker-reinforced ceramics. It may also be used for glasses. It is not applicable to continuous fiber-reinforced ceramic composites.

1.2 The values stated in SI units are to be regarded as the standard. The values given in parentheses are for information only.

1.3 *This standard does not purport to address all of the safety concerns, if any, associated with its use. It is the responsibility of the user of this standard to establish appropriate safety, health, and environmental practices and determine the applicability of regulatory limitations prior to use.*

1.4 *This international standard was developed in accordance with internationally recognized principles on standardization established in the Decision on Principles for the Development of International Standards, Guides and Recommendations issued by the World Trade Organization Technical Barriers to Trade (TBT) Committee.*

<sup>1</sup> This test method is under the jurisdiction of ASTM Committee C28 on Advanced Ceramics and is the direct responsibility of Subcommittee C28.01 on Mechanical Properties and Performance.

Current edition approved Jan. 1, 2018. Published January 2018. Originally approved in 1992. Last previous edition approved in 2013 as C1211 – 13. DOI: 10.1520/C1211-18.

<sup>2</sup> Elevated temperatures typically denote, but are not restricted to, 200 to 1600 °C.

## 2. Referenced Documents

### 2.1 ASTM Standards:<sup>3</sup>

- C1161 Test Method for Flexural Strength of Advanced Ceramics at Ambient Temperature
- C1239 Practice for Reporting Uniaxial Strength Data and Estimating Weibull Distribution Parameters for Advanced Ceramics
- C1322 Practice for Fractography and Characterization of Fracture Origins in Advanced Ceramics
- C1341 Test Method for Flexural Properties of Continuous Fiber-Reinforced Advanced Ceramic Composites
- C1368 Test Method for Determination of Slow Crack Growth Parameters of Advanced Ceramics by Constant Stress-Rate Strength Testing at Ambient Temperature
- C1465 Test Method for Determination of Slow Crack Growth Parameters of Advanced Ceramics by Constant Stress-Rate Flexural Testing at Elevated Temperatures
- E4 Practices for Force Verification of Testing Machines
- E220 Test Method for Calibration of Thermocouples By Comparison Techniques
- E230 Specification and Temperature-Electromotive Force (EMF) Tables for Standardized Thermocouples - 18

## 3. Terminology

### 3.1 Definitions:

3.1.1 *complete gage section, n*—the portion of the specimen between the two outer bearings in four-point flexure and three-point flexure fixtures.

NOTE 1—In this standard, the complete four-point flexure gage section is twice the size of the inner gage section. Weibull statistical analyses, in this instance, only include portions of the specimen volume or surface which experience tensile stresses.

3.1.2 *flexural strength,  $[FL^{-2}]$ , n*—a measure of the ultimate strength of a specified beam in bending.

3.1.3 *four-point- $\frac{1}{4}$ -point flexure, n*—a configuration of flexural strength testing in which a specimen is symmetrically

<sup>3</sup> For referenced ASTM standards, visit the ASTM website, www.astm.org, or contact ASTM Customer Service at service@astm.org. For *Annual Book of ASTM Standards* volume information, refer to the standard's Document Summary page on the ASTM website.

\*A Summary of Changes section appears at the end of this standard

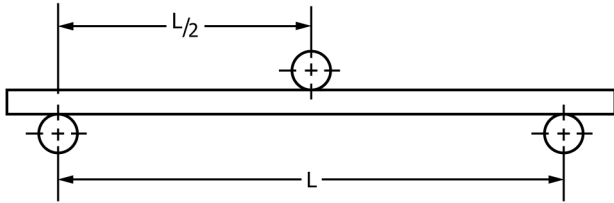
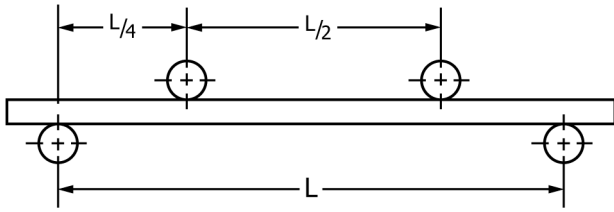

NOTE 1—Configuration:

- A: L = 20 mm
- B: L = 40 mm
- C: L = 80 mm

FIG. 1 Four-Point-1/4-Point and Three-Point Fixture Configurations

loaded at two locations that are situated at one-quarter of the overall span, away from the outer two support bearings (see Fig. 1).

3.1.4 *fully articulating fixture, n*—a flexure fixture designed to be used either with flat and parallel specimens or with uneven or nonparallel specimens. The fixture allows full independent articulation, or pivoting, of all rollers about the specimen long axis to match the specimen surface. In addition, the upper or lower pairs are free to pivot to distribute force evenly to the bearing cylinders on either side.

NOTE 2—See Annex A1 for schematic illustrations of the required pivoting movements.

NOTE 3—A three-point fixture has the inner pair of bearing cylinders replaced by a single bearing cylinder.

3.1.5 *inert flexural strength,  $[FL^{-2}]$ , n*—a measure of the strength of a specified beam specimen in bending as determined in an appropriate inert condition whereby no slow crack growth occurs.

3.1.6 *inherent flexural strength,  $[FL^{-2}]$ , n*—the flexural strength of a material in the absence of any effect of surface grinding or other surface finishing process, or of extraneous damage that may be present. The measured inherent strength is in general a function of the flexure test method, test conditions, and test specimen size.

3.1.7 *inner gage section, n*—the portion of the specimen between the inner two bearings in a four-point flexure fixture.

3.1.8 *semi-articulating fixture, n*—a flexure fixture designed to be used with flat and parallel specimens. The fixture allows some articulation, or pivoting, to ensure the top pair (or bottom pair) of bearing cylinders pivot together about an axis parallel to the specimen long axis, in order to match the specimen

surfaces. In addition, the upper or lower pairs are free to pivot to distribute force evenly to the bearing cylinders on either side.

NOTE 4—See Annex A1 for schematic illustrations of the required pivoting movements.

NOTE 5—A three-point fixture has the inner pair of bearing cylinders replaced by a single bearing cylinder.

3.1.9 *slow crack growth (SCG), n*—subcritical crack growth (extension) which may result from, but is not restricted to, such mechanisms as environmentally assisted stress corrosion or diffusive crack growth.

3.1.10 *three-point flexure, n*—a configuration of flexural strength testing in which a specimen is loaded at a position midway between two support bearings (see Fig. 1).

#### 4. Significance and Use

4.1 This test method may be used for material development, quality control, characterization, and design data generation purposes. This test method is intended to be used with ceramics whose flexural strength is ~50 MPa (~7 ksi) or greater.

4.2 The flexure stress is computed based on simple beam theory, with assumptions that the material is isotropic and homogeneous, the moduli of elasticity in tension and compression are identical, and the material is linearly elastic. The average grain size should be no greater than 1/50 of the beam thickness. The homogeneity and isotropy assumptions in the test method rule out the use of it for continuous fiber-reinforced composites for which Test Method C1341 is more appropriate.

4.3 The flexural strength of a group of test specimens is influenced by several parameters associated with the test procedure. Such factors include the testing rate, test environment, specimen size, specimen preparation, and test fixtures. Specimen and fixture sizes were chosen to provide a balance between the practical configurations and resulting errors as discussed in Test Method C1161, and Refs (1-3).<sup>4</sup> Specific fixture and specimen configurations were designated in order to permit the ready comparison of data without the need for Weibull size scaling.

4.4 The flexural strength of a ceramic material is dependent on both its inherent resistance to fracture and the size and severity of flaws. Variations in these cause a natural scatter in test results for a sample of test specimens. Fractographic analysis of fracture surfaces, although beyond the scope of this test method, is highly recommended for all purposes, especially if the data will be used for design as discussed in Ref (4) and Practices C1322 and C1239.

4.5 This method determines the flexural strength at elevated temperature and ambient environmental conditions at a nominal, moderately fast testing rate. The flexural strength under these conditions may or may not necessarily be the inert flexural strength. Flexure strength at elevated temperature may be strongly dependent on testing rate, a consequence of creep, stress corrosion, or slow crack growth. If the purpose of the test

<sup>4</sup> The boldface numbers in parentheses refer to the list of references at the end of the text.

is to measure the inert flexural strength, then extra precautions are required and faster testing rates may be necessary.

NOTE 6—Many ceramics are susceptible to either environmentally assisted slow crack growth or thermally activated slow crack growth. Oxide ceramics, glasses, glass ceramics, and ceramics containing boundary phase glass are particularly susceptible to slow crack growth. Time-dependent effects that are caused by environmental factors (for example, water as humidity in air) may be minimized through the use of inert testing atmosphere such as dry nitrogen gas or vacuum. Alternatively, testing rates faster than specified in this standard may be used if the goal is to measure the inert strength. Thermally activated slow crack growth may occur at elevated temperature even in inert atmospheres. Testing rates faster than specified in this standard should be used if the goal is to measure the inert flexural strength. On the other hand, many ceramics such as boron carbide, silicon carbide, aluminum nitride, and many silicon nitrides have no sensitivity to slow crack growth at room or moderately elevated temperatures and for such materials, the flexural strength measured under laboratory ambient conditions at the nominal testing rate is the inert flexural strength.

4.6 The three-point test configuration exposes only a very small portion of the specimen to the maximum stress. Therefore, three-point flexural strengths are likely to be much greater than four-point flexural strengths. Three-point flexure has some advantages. It uses simpler test fixtures, it is easier to adapt to high temperature, and it is sometimes helpful in Weibull statistical studies. However, four-point flexure is preferred and recommended for most characterization purposes.

4.7 The three-point test configuration exposes only a very small portion of the specimen to the maximum stress. Therefore, three-point flexural strengths are likely to be much greater than four-point flexural strengths. Three-point flexure has some advantages. It uses simpler test fixtures, it is easier to adapt to high temperature, and it is sometimes helpful in Weibull statistical studies. However, four-point flexure is preferred and recommended for most characterization purposes.

5. Interferences

5.1 Time-dependent phenomena, such as stress corrosion and slow crack growth, can interfere with determination of the flexural strength at room and elevated temperatures. Creep phenomena also become significant at elevated temperatures. Creep deformation can cause stress relaxation in a flexure specimen during a strength test, thereby causing the elastic formulation that is used to compute the strength to be in error.

5.2 Surface preparation of the test specimens can introduce machining damage such as microcracks that may have a pronounced effect on flexural strength. Machining damage imposed during specimen preparation can be either a random interfering factor or an inherent part of the strength characteristic to be measured. With proper care and good machining practice, it is possible to obtain fractures from the material’s natural flaws. Surface preparation can also lead to residual stresses. Universal or standardized test methods of surface preparation do not exist. It should be understood that final machining steps may or may not negate machining damage introduced during the early coarse or intermediate machining.

5.3 Slow crack growth can lead to a rate dependency of flexural strength. The testing rate specified in this standard may

TABLE 1 Fixture Spans

Configuration	Support Span (L), mm	Loading Span, mm
A	20	10
B	40	20
C	80	40

or may not produce the inert flexural strength whereby negligible slow crack growth occurs. See Test Methods C1368 and C1465 and Ref (5) for more information about possible rate dependencies of flexural strength and methodologies for quantifying the rate sensitivity

6. Apparatus

6.1 Loading—Specimens may be force in any suitable testing machine provided that uniform rates of direct loading can be maintained. The force measuring system shall be free of initial lag at the loading rates used and shall be equipped with a means for retaining readout of the maximum force as well as a force-time or force-deflection record. The accuracy of the testing machine shall be in accordance with Practices E4.<sup>5</sup>

6.2 Four-Point Flexure Four-Point-1/4-Point Fixtures (Fig. 1), having support spans as given in Table 1.

6.3 Three-Point Flexure Three-Point Fixtures (Fig. 1), having a support span as given in Table 1.

6.4 Bearings, Three- and four-point flexure.

6.4.1 Cylindrical bearings shall be used for support of the test specimen and for load application. The cylinders may be made of a ceramic with an elastic modulus between 200 and 400 GPa (30 to 60 × 10<sup>6</sup> psi) and a flexural strength no less than 275 MPa (≈40 ksi). The loading cylinders must remain elastic (and have no plastic deformation) over the load and temperature ranges used, and they must not react chemically with or contaminate the test specimen. The test fixture shall also be made of a ceramic that is resistant to permanent deformation.

6.4.2 The bearing cylinder diameter shall be approximately 1.5 times the beam depth of the test specimen size used (see Table 2).

6.4.3 The bearing cylinders shall be positioned carefully such that the spans are accurate to within ±0.10 mm. The load application bearing for the three-point configurations shall be positioned midway between the support bearings within ±0.10 mm. The load application (inner) bearings for the four-point configurations shall be centered with respect to the support (outer) bearings within ±0.10 mm.

6.4.4 The bearing cylinders shall be free to rotate in order to relieve frictional constraints (with the exception of the middle load bearing in three-point flexure, which need not rotate). This can be accomplished as shown in Figs. 2 and 3. Annex A1 illustrates the action required of the bearing cylinders. Note

<sup>5</sup> The accuracy requirement is different from that specified in Test Method C1161 and is a concession to difficulties incurred in conducting elevated temperature testing. The accuracy required by Practices E4 is 1 %; Test Method C1161 calls for 0.5 %.

TABLE 2 Nominal Bearing Diameters

Configuration	Diameter, mm
A	2.0 to 2.5
B	4.5
C	9.0

two inner bearings shall be parallel to each other to within 0.015 mm over their length. The two outer bearings shall be parallel to each other to within 0.015 mm over their length. The inner bearings shall be supported independently of the outer bearings. All four bearings shall rest uniformly and evenly across the specimen surfaces. The fixture shall be designed to apply equal load to all four bearings.

6.6 *Fully Articulating Four-Point Fixture*—Specimens that are as-fired, heat treated, or oxidized often have slight twists or unevenness. Specimens that do not meet the parallelism requirements of 7.1 shall be tested in a fully articulating fixture as illustrated in Fig. 3 and in Fig. A1.1(b). Well-machined specimens may also be tested in fully articulating fixtures. All four bearings shall be free to roll. One bearing need not articulate. The other three bearings shall articulate to match the specimen’s surface. All four bearings shall rest uniformly and evenly across the specimen surfaces. The fixture shall apply equal load to all four bearings.

6.7 *Semi-Articulated Three-Point Fixture*—Specimens prepared in accordance with the parallelism requirements of 7.1 may be tested in a semi-articulating fixture as illustrated in Fig. A1.2(a). The middle bearing shall be fixed and not free to roll. The two outer bearings shall articulate together to match the specimen surface, or the middle bearing shall articulate to match the specimen surface. All three bearings shall rest uniformly and evenly across the specimen surface. The fixture shall be designed to apply equal load to the two outer bearings.

6.8 *Fully Articulated Three-Point Flexure*—Specimens that do not meet the parallelism requirements of 7.1 shall be tested in a fully articulating fixture as illustrated in Fig. A1.2(b) or Fig. A1.2(c). Well-machined specimens may also be tested in fully articulating fixtures. The two support (outer) bearings shall be free to roll outwards. The middle bearing shall not roll. Any two of the bearings shall be capable of articulating to match the specimen surface. All three bearings shall rest uniformly and evenly across the specimen surface. The fixture shall be designed to apply equal load to the two outer bearings.

6.9 *System Compliance*—The compliance of the load train shall be characterized for the loading range used and the testing temperature.<sup>7</sup> The load train and fixtures shall be sufficiently rigid so that at least 80 % of the crosshead motion is transmitted to the actual test specimens. The load train and fixtures shall not permanently deform during testing. It is not necessary to check the system compliance for every test sequence, provided that it has been characterized previously for the identical setup.

<sup>7</sup> Compliance can be measured by inserting an oversized block onto the flexure fixture, loading it to the maximum expected break force at the test temperature, and recording a load-deflection graph. The block must be a ceramic material that will remain elastic under these conditions. The compliance check shall be made with the entire force train in place, especially the load bearing rollers. It is recommended that the block be at least five times thicker than the normal test specimen and one to two times thicker than the normal specimen width.

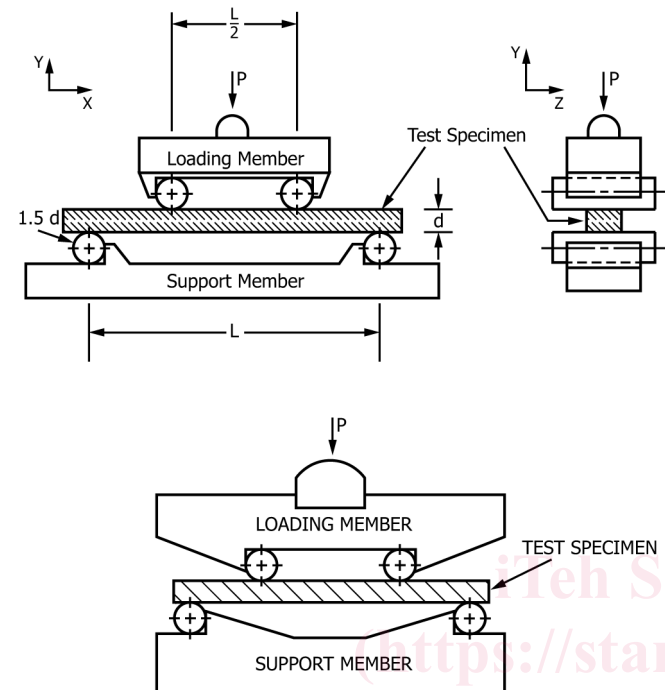

NOTE 1—Configuration:  
A: L = 20 mm  
B: L = 40 mm  
C: L = 80 mm

NOTE 2—Load is applied through a rounded and well-centered tip that permits the loading member to tilt as necessary to ensure uniform loading.

FIG. 2 Schematics of Semi-Articulated Four-Point Fixtures Suitable for Flat and Parallel Specimens

that the outer support bearings roll outward and the inner loading bearings roll inward.<sup>6</sup>

6.5 *Semi-Articulating Four-Point Fixture*—Specimens prepared in accordance with the parallelism requirements of 7.1 may be tested in a semi-articulating fixture as illustrated in Fig. 2 and in Fig. A1.1(a). All four bearings shall be free to roll. The

<sup>6</sup> In general, fixed-pin fixtures have frictional constraints that can cause a systematic error on the order of 5 to 15 % in flexure strength (see Refs (1, 2, 4-7)). Since this error is systematic (constant for all specimens in a sample), it will lead to a bias in estimates of the mean strength and will shift a Weibull curve a fixed amount of stress. The scatter, however, will remain constant.

Rolling-pin fixtures are required by this test method. It is recognized that they may not be feasible in some instances, in which case fixed-pin fixtures may be used, but this must be stated explicitly in the report, and justification must be given as noted in 10.1.16.

Some fixtures have loading cylinders that fit into square slots with a slight clearance. Of course, the clearance must be such that the possible spans are within the prescribed limits of this test method. Unfortunately, for any given test, it is usually not possible to ascertain whether a roller rests against an inner or outer shoulder, and thus it is possible that some rollers may be free to roll and others not. This can lead to the superimposition of a random error on the results. Such fixtures should therefore be used with caution.

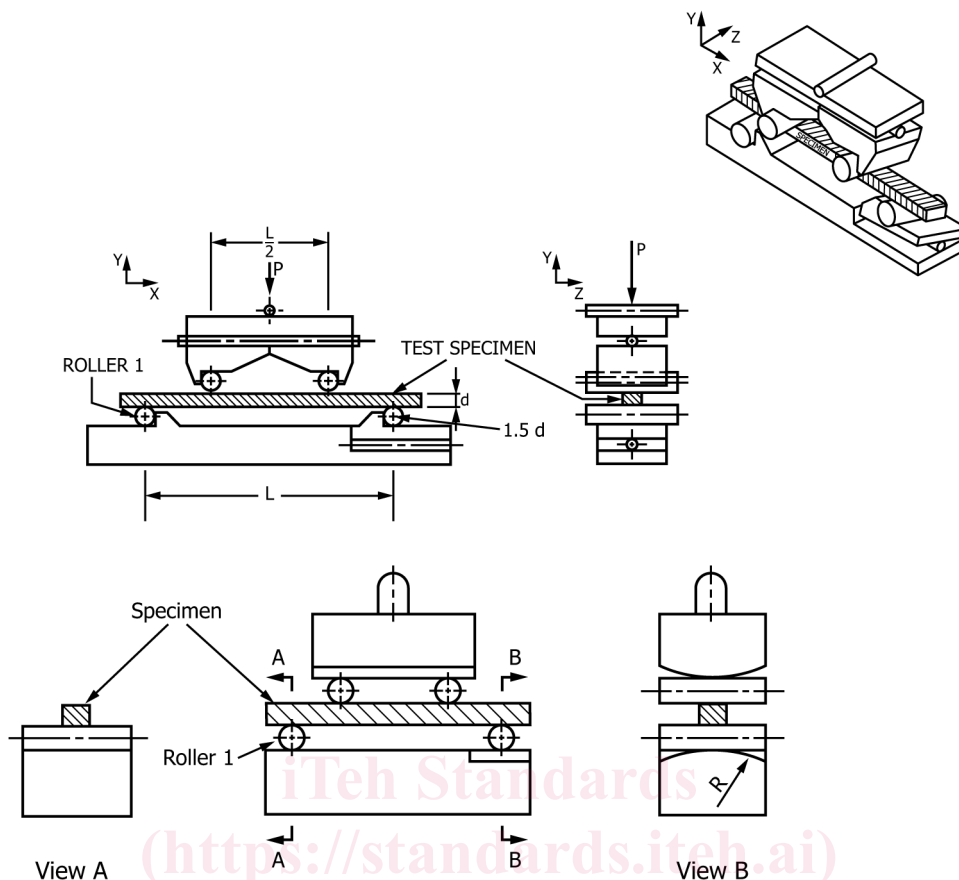

NOTE 1—Configuration:

- A: L = 20 mm
- B: L = 40 mm
- C: L = 80 mm

NOTE 2—One of the four load bearings (for example, Roller No. 1) should not articulate about the  $x$  axis. The other three will provide the necessary degrees of freedom. The radius  $R$  in the bottom fixture should be sufficiently large such that contact stresses on the roller are minimized.

FIG. 3 Schematics of Fully Articulating Four-Point Fixtures Suitable for Twisted or Uneven Specimens

6.10 *Fixture Material*, essentially inert for the testing conditions used. The fixture shall be oxidation resistant if the testing is performed in air.<sup>8</sup>

6.11 *Heating Apparatus*—A furnace capable of meeting the following requirements:

6.11.1 The furnace shall be capable of establishing and maintaining a constant temperature during each testing period. The variation in temperature during the test shall be within

<sup>8</sup> Various grades of silicon carbide are available that will be suitable for fixtures and load trains. Hot-pressed or sintered silicon carbides with low additive content are elastic to temperatures in excess of 1500 °C. Siliconized silicon carbides and high-purity aluminas are less expensive and are available in a variety of shapes, but they exhibit creep deformations at temperatures above 1200 °C. Recrystallized silicon carbides are elastic to temperatures up to 2000 °C but are relatively weak due to their porosity. Graphites are extremely refractory but are restricted to usage in inert atmospheres. They may suffice for load rams or portions of fixtures, but they should be avoided for use where there are concentrated loads, such as loading bearings, since graphite is too soft. Avoid materials that will oxidize significantly at test temperatures (if testing in air) or that will react chemically with or contaminate test specimens.

±2 °C. The temperature readout device shall have a resolution of 1 °C or lower. The furnace system shall be such that thermal gradients are minimal in the flexure specimen, so that no more than a 5 °C differential exists from end to end in the specimen.

6.11.2 The specimen temperature shall be monitored by a thermocouple with its tip located no more than 1 mm from the midpoint of the flexure specimen. Either a fully sheathed or exposed bead junction may be used. If a sheathed tip is used, it must be verified that there is negligible error associated with the covering.<sup>9,10</sup>

<sup>9</sup> Exposed thermocouple beads have greater sensitivity, but they may be exposed to vapors that can react with the thermocouple materials. (For example, silica vapors will react with platinum.) Beware of the use of heavy-gage thermocouple wire, thermal gradients along the thermocouple length, or excessively heavy-walled insulators, all of which can lead to erroneous temperature readings.

<sup>10</sup> The thermocouple tip may contact the flexure specimen, but only if there is certainty that the thermocouple tip or sheathing material will not interact chemically with the specimen. Thermocouples may be prone to breakage if they are in contact with the specimen.

**TABLE 3 Specimen Sizes**

Configuration	Width ( <i>b</i> ), mm	Depth ( <i>d</i> ), mm	Length ( <i>L</i> <sub>T</sub> ), mm, min
A	2.0	1.5	25
B	4.0	3.0	45
C	8.0	6.0	90

6.11.3 A separate thermocouple may be used to control the furnace chamber if necessary, but the specimen temperature shall be the reported temperature of the test.<sup>11</sup>

6.11.4 The thermocouple(s) shall be calibrated in accordance with Test Method E220 and Specification E230.<sup>12</sup>

6.11.5 The temperature shall be accurate to within  $\pm 5$  °C. The accuracy shall include the error inherent to the thermocouple as well as any errors in the measuring instruments.<sup>13,14</sup>

6.11.6 The appropriate thermocouple extension wire should be used to connect a thermocouple to the furnace controller and temperature readout device, which must have either a cold junction or a room temperature compensation circuit. Special attention should be directed toward connecting the extension wire with the correct polarity.

6.11.7 The furnace may have an air, inert, or vacuum environment, as required. If an inert or vacuum chamber is used, and it is necessary to direct load through a bellows, fittings, or seal, it shall be verified that load losses or errors do not exceed 1 % of the expected failure loads.

6.12 *System Equilibrium*—The time for the system to reach thermal equilibrium at test temperature shall be determined for the test temperature to be used. This shall be performed for both hot-furnace loading, in accordance with 8.4, or cold-furnace loading, in accordance with 8.3. This determination can be accomplished during the compliance check specified in 6.9.

6.13 *Micrometer*—A micrometer with a resolution of 0.002 mm (or 0.0001 in.) or smaller should be used to measure the test specimen dimensions. The micrometer shall have flat anvil faces. The micrometer shall not have a ball tip or sharp tip since these might damage the test specimen if the specimen dimensions are measured prior to fracture. Alternative dimension measuring instruments may be used provided that they have a resolution of 0.002 mm (or 0.0001 in.) or finer and do no harm to the specimen.

## 7. Specimens

7.1 *Specimen Size*—Dimensions are given in Table 3 and shown in Fig. 4. Cross-sectional dimensional tolerances are  $\pm 0.13$  mm for B and C specimens and  $\pm 0.05$  for A specimens. The parallelism tolerances on the four longitudinal faces are

<sup>11</sup> Flexure tests are sometimes conducted in furnaces that have thermal gradients. The small size of flexure specimens will alleviate thermal gradient problems, but it is essential to monitor the temperature at the specimen.

<sup>12</sup> Thermocouples should be checked periodically since calibration may drift with usage or contamination.

<sup>13</sup> Resolution should not be confused with accuracy. Beware of recording instruments that read out to 1 °C (resolution) but have an accuracy of only  $\pm 10$  °C or  $\pm 1/2$  % of full scale (for example,  $1/2$  % of 1200 °C is 6 °C).

<sup>14</sup> Temperature measuring instruments typically approximate the temperature-electromotive force (EMF, that is, millivolt) tables, but with a few degrees of error.

0.015 mm for A and B specimens and 0.03 mm for C specimens. The two end faces need not be precision machined.

7.2 *Specimen Preparation*—Depending on the intended application of the flexural strength data, use one of the following four specimen preparation procedures:

7.2.1 *As-Fabricated*—The flexure specimen shall simulate the surface condition of an application in which no machining is used, for example, as-cast, sintered, or injection-molded parts. No additional machining specifications are relevant. An edge chamfer is not necessary in this instance. As-fired specimens are especially prone to twist or warpage and may not meet the parallelism requirements. A fully articulating fixture (see 6.6 and Fig. 3) shall be used in this instance.

7.2.2 *Application-Matched Machining*—The specimen shall be given the same surface preparation as that given to a component. Unless the process is proprietary, the report shall be specific concerning the stages of material removal, wheel grits, wheel bonding, and the amount of material removed per pass.

7.2.3 *Customary Procedure*—This procedure shall be used in instances in which a customary machining procedure has been developed that is completely satisfactory for a class of materials (that is, it induces no unwanted surface damage or residual stresses). It shall be fully specified in the report.

7.2.4 *Standard Procedure*—In the instances in which 7.2.1 – 7.2.3 are not appropriate, the “Standard Procedure” option in 7.2.4 of Test Method C1161 shall apply. All machining shall be parallel to the specimen long axis as shown in Fig. 5. No Blanchard or rotary grinding shall be used.

7.2.4.1 The four long edges of each B-sized test specimen shall be chamfered uniformly at 45°, a distance of  $0.12 \pm 0.03$  mm, as shown in Fig. 4. They can alternatively be rounded with a radius of  $0.15 \pm 0.05$  mm. Edge finishing shall be comparable to that applied to the test specimen surfaces. In particular, the direction of machining shall be parallel to the test specimen long axis. If chamfers are larger than the tolerance allows, corrections shall be made to the stress calculation in accordance with Annex A2 of Test Method C1161. Smaller chamfer or rounded edge sizes are recommended for A-test bars. Larger chambers or rounded edges may be used with C-test specimens. Consult Annex A2 of Test Method C1161 for guidance and whether corrections for flexural strength are necessary. No chipping is allowed. Up to 50× magnification may be used to verify this. Alternatively, if a test specimen can be prepared with an edge that is free of machining damage, then a chamfer is not required.

7.2.5 *Handling Precautions*—Exercise care in the storing and handling of specimens to avoid the introduction of random and severe flaws, such as might occur if the specimens were allowed to impact or scratch each other.

7.3 *Number of Specimens*—A minimum of ten specimens shall be required for the purpose of estimating the mean. A minimum of 30 shall be necessary if estimates regarding the form of the strength distribution are to be reported (for example, a Weibull modulus). The number of specimens required by this test method has been established with the intent of determining not only reasonable confidence limits on strength distribution parameters, but also to help discern