

---

---

**Aerospace — Nuts, hexagonal, slotted (castellated), normal height, normal across flats, with MJ threads, classifications:**  
**600 MPa (at ambient temperature)/120 °C,**  
**600 MPa (at ambient temperature)/235 °C,**  
**900 MPa (at ambient temperature)/425 °C,**  
**1 100 MPa (at ambient temperature)/235 °C,**  
**1 100 MPa (at ambient temperature)/315 °C,**  
**1 100 MPa (at ambient temperature)/650 °C,**  
**1 210 MPa (at ambient temperature)/730 °C,**  
**1 250 MPa (at ambient temperature)/235 °C and**  
**1 550 MPa (at ambient temperature)/600 °C —**  
**Dimensions**

*Aéronautique et espace — Écrous hexagonaux à créneaux, hauteur normale, surplats normaux, à filetage MJ, classifications: 600 MPa (à température ambiante)/120 °C, 600 MPa (à température ambiante)/235 °C, 900 MPa (à température ambiante)/425 °C, 1 100 MPa (à température ambiante)/235 °C, 1 100 MPa (à température ambiante)/315 °C, 1 100 MPa (à température ambiante)/650 °C, 1 210 MPa (à température ambiante)/730 °C, 1 250 MPa (à température ambiante)/235 °C et 1 550 MPa (à température ambiante)/600 °C — Dimensions*



## Foreword

ISO (the International Organization for Standardization) is a worldwide federation of national standards bodies (ISO member bodies). The work of preparing International Standards is normally carried out through ISO technical committees. Each member body interested in a subject for which a technical committee has been established has the right to be represented on that committee. International organizations, governmental and non-governmental, in liaison with ISO, also take part in the work. ISO collaborates closely with the International Electrotechnical Commission (IEC) on all matters of electrotechnical standardization.

Draft International Standards adopted by the technical committees are circulated to the member bodies for voting. Publication as an International Standard requires approval by at least 75 % of the member bodies casting a vote.

International Standard ISO 4147 was prepared by Technical Committee ISO/TC 20, *Aircraft and space vehicles*, Subcommittee SC 4, *Aerospace fastener systems*.

This third edition cancels and replaces the second edition (ISO 4147:1983), of which it constitutes a technical revision.

© ISO 1997

All rights reserved. Unless otherwise specified, no part of this publication may be reproduced or utilized in any form or by any means, electronic or mechanical, including photocopying and microfilm, without permission in writing from the publisher.

International Organization for Standardization  
Case postale 56 • CH-1211 Genève 20 • Switzerland  
Internet central@iso.ch  
X.400 c=ch; a=400net; p=iso; o=isocs; s=central

Printed in Switzerland

## Introduction

The dimensions specified in this International Standard have been determined to satisfy the requirements of the procurement specification of ISO 9139.

**iTeh STANDARD PREVIEW**  
**(standards.iteh.ai)**

ISO 4147:1997

<https://standards.iteh.ai/catalog/standards/sist/e023b3ea-a658-4c35-bb2c-a0e7dde7fde2/iso-4147-1997>

**iTeh STANDARD PREVIEW**  
This page intentionally left blank  
**(standards.iteh.ai)**

ISO 4147:1997

<https://standards.iteh.ai/catalog/standards/sist/e023b3ea-a658-4c35-bb2c-a0e7dde7fde2/iso-4147-1997>

**Aerospace — Nuts, hexagonal, slotted (castellated), normal height, normal across flats, with MJ threads, classifications: 600 MPa (at ambient temperature)/120 °C, 600 MPa (at ambient temperature)/235 °C, 900 MPa (at ambient temperature)/425 °C, 1 100 MPa (at ambient temperature)/235 °C, 1 100 MPa (at ambient temperature)/315 °C, 1 100 MPa (at ambient temperature)/650 °C, 1 210 MPa (at ambient temperature)/730 °C, 1 250 MPa (at ambient temperature)/235 °C and 1 550 MPa (at ambient temperature)/600 °C — Dimensions**

## 1 Scope

This International Standard specifies the dimensions of hexagon slotted (castellated) nuts, normal height, normal across flats, with MJ threads, of classifications: 600 MPa<sup>1)</sup>/120 °C<sup>2)</sup>, 600 MPa<sup>1)</sup>/235 °C<sup>2)</sup>, 900 MPa<sup>1)</sup>/425 °C<sup>2)</sup>, 1 100 MPa<sup>1)</sup>/235 °C<sup>2)</sup>, 1 100 MPa<sup>1)</sup>/315 °C<sup>2)</sup>, 1 100 MPa<sup>1)</sup>/650 °C<sup>2)</sup>, 1 210 MPa<sup>1)</sup>/730 °C<sup>2)</sup>, 1 250 MPa<sup>1)</sup>/235 °C<sup>2)</sup> and 1 550 MPa<sup>1)</sup>/600 °C<sup>2)</sup>.

These nuts are intended to be used with split pins in conformity with ISO 1234.

This International Standard is only applicable for the compilation of aerospace product standards.

## 2 Normative references

The following standards contain provisions which, through reference in this text, constitute provisions of this International Standard. At the time of publication, the editions indicated were valid. All standards are subject to revision, and parties to agreements based on this International Standard are encouraged to investigate the possibility of applying the most recent editions of the standards indicated below. Members of IEC and ISO maintain registers of currently valid International Standards.

ISO 1234:—<sup>3)</sup>, *Split pins*.

ISO 5855-2:1988, *Aerospace — MJ threads — Part 2: Limit dimensions for bolts and nuts*.

ISO 8788:1987, *Aerospace — Fasteners — Tolerances of form and position for nuts*.

ISO 9139:—<sup>4)</sup>, *Aerospace — Nuts, plain or slotted (castellated) — Procurement specification*.

1) Corresponds to the minimum tensile stress which the nut is able to withstand at ambient temperature without breaking or cracking when tested with a bolt of a higher strength class.

2) Maximum temperature that the nut is able to withstand, without permanent alteration to its original characteristics, after ambient temperature has been restored. The maximum temperature is conditioned by the material or by the surface treatment.

3) To be published. (Revision of ISO 1234:1976)

4) To be published.

### 3 Configuration and dimensions

See figure 1 and table 1. Dimensions and tolerances are expressed in millimetres. They apply after any surface coating(s) but before the application of any lubricant.

$$6,3 \sqrt{\left(1,6 \sqrt{\quad}\right)^n}$$

Remove sharp edges 0,1 to 0,4

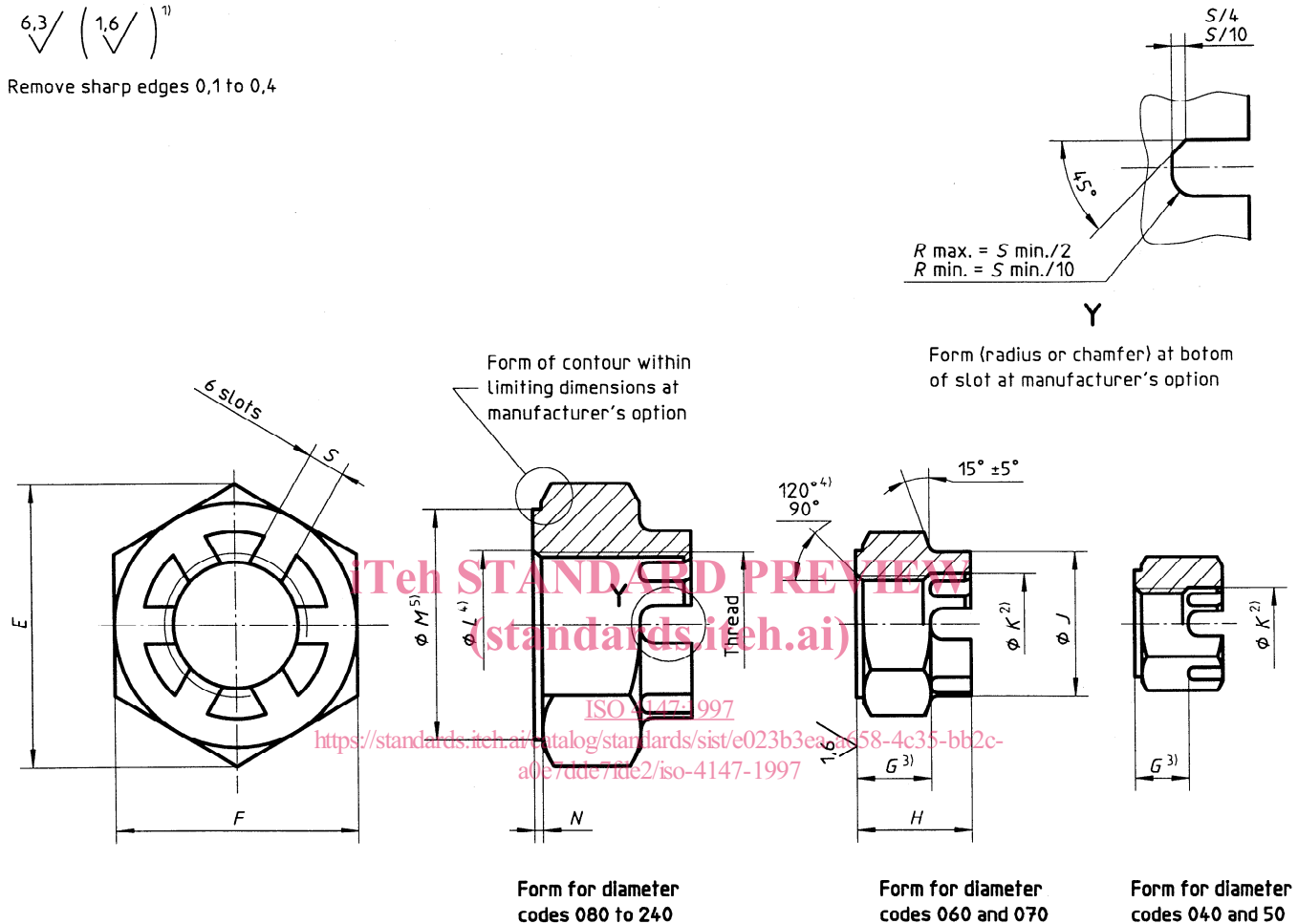

NOTE — Tolerances of form and position shall conform to those specified in ISO 8788. Details of form not stated are at the manufacturer's discretion.

- 1) These values, in micrometres, apply before any surface coating(s) is (are) applied. The values do not apply to threads the surface texture of which will be as achieved by the usual manufacturing methods.
- 2) Tooling marks permissible within counterbore.
- 3) Applies to:
  - height below slots;
  - height of flats (diameter codes 060 to 240);
  - bottom of counterbore.
- 4) This dimension also applies to the upper chamfer. All forms of entry (chamfer or radius) permissible within these limiting dimensions.
- 5) Diameter *M* may be tangential to, but shall not intrude on the flats.

Figure 1

Table 1

Diameter code	Thread <sup>1)</sup>	E min.	F		G ± 0,25	H ± 0,25	J ± 0,25	K H15	L		M min.	N $\begin{matrix} 0 \\ -0,3 \end{matrix}$	S H14	Maximum split pin diameter <sup>2)</sup>
040	MJ4×0,7 – 4H6H	7,6	7	h12	3	5	—	4	4,2	$\begin{matrix} +0,6 \\ 0 \end{matrix}$	6,4	0,5	1,3	1
050	MJ5×0,8 – 4H6H	8,7	8		3,75	6,2	—	5	5,2		7,4		1,7	1,4
060	MJ6×1 – 4H5H	10,9	10	h13	4,5	6,9	9	6	6,3	$\begin{matrix} +0,8 \\ 0 \end{matrix}$	9,3	0,6	2,1	1,8
070	MJ7×1 – 4H5H	12	11		5,25	8,1	10	7	7,3		10,2		2,6	2,3
080	MJ8×1 – 4H5H	14,3	13		6	8,8	11	—	8,3		12,2	0,6	4	3,7
100	MJ10×1,25 – 4H5H	18,9	17		7,5	11,1	13	—	10,3		16			
120	MJ12×1,25 – 4H5H	21,1	19		9	12,6	16	—	12,3		18	0,6	4	3,7
140	MJ14×1,5 – 4H5H	24,5	22		10,5	14,9	18	—	14,4		21			
160	MJ16×1,5 – 4H5H	26,8	24		12	16,4	22	—	16,4		23			
180	MJ18×1,5 – 4H5H	30,2	27		13,5	18,7	25	—	18,4		26			
200	MJ20×1,5 – 4H5H	33,6	30		15	20,2	28	—	20,4		29			
220	MJ22×1,5 – 4H5H	35,8	32		16,5	21,7	30	—	22,4		30,9			
240	MJ24×2 – 4H5H	40,4	36	18	23,7	32	—	24,5	34,9					

1) In accordance with ISO 5855-2  
2) For information, in conformity with ISO 1234 for the split pin maximum diameter but not for the split pin maximum diameter/thread diameter combination

**iTeh STANDARD PREVIEW**  
**(standards.iteh.ai)**

ISO 4147:1997

<https://standards.iteh.ai/catalog/standards/sist/e023b3ea-a658-4c35-bb2c-a0e7dde7fde2/iso-4147-1997>

---

---

**ICS 49.030.30**

**Descriptors:** aircraft industry, fasteners, MJ threads, nuts (fasteners), hexagonal nuts, castle nuts, classification, form specifications, dimensions.

Price based on 3 pages

---

---