



# Standard Test Methods for Evaluating Design and Performance Characteristics of Selectorized Strength Equipment<sup>1</sup>

This standard is issued under the fixed designation F2277; the number immediately following the designation indicates the year of original adoption or, in the case of revision, the year of last revision. A number in parentheses indicates the year of last reapproval. A superscript epsilon ( $\epsilon$ ) indicates an editorial change since the last revision or reapproval.

## INTRODUCTION

The goal of these test methods is to provide reliable and repeatable methods for the evaluation of selectorized strength equipment. Users of these machines must recognize, however, that conformance to a standard will not necessarily prevent injuries. Certain physical conditions or limitations may preclude some persons from using this equipment as intended by the manufacturer, and using this equipment may increase the risk of injury.

## 1. Scope

1.1 These test methods specify procedures and apparatus used for testing and evaluating selectorized strength equipment for compliance to Specification **F2216**. Both design and operational parameters will be evaluated. Where possible and applicable, accepted test methods from other recognized bodies will be used and referenced.

1.2 *Requirements*—Selectorized strength equipment is to be tested in accordance with these test methods or Test Methods **F2571** for all of the following parameters:

- 1.2.1 Stability,
- 1.2.2 Edge and corner sharpness,
- 1.2.3 Tube ends,
- 1.2.4 Weight stack travel,
- 1.2.5 Weight stack selector pin retention,
- 1.2.6 Function of adjustments and locking mechanisms,
- 1.2.7 Handgrip design and retention,
- 1.2.8 Assist mechanisms,
- 1.2.9 Foot supports,
- 1.2.10 Rope and belt systems:
  - 1.2.10.1 Static load,
  - 1.2.10.2 End fitting design,
- 1.2.11 Chain drive design,
- 1.2.12 Pulley design:
  - 1.2.12.1 Rope pulley design,
  - 1.2.12.2 Belt pulley design,
- 1.2.13 Entrapment zones,
- 1.2.14 Pull in points,
- 1.2.15 Weight stack enclosure design,
- 1.2.16 Loading and deflection:
  - 1.2.16.1 Intrinsic loading and associated deflection,
  - 1.2.16.2 Extrinsic loading and associated deflection,
  - 1.2.16.3 Endurance loading,
- 1.2.17 Documentation and warnings verification, and

<sup>1</sup> These test methods are under the jurisdiction of ASTM Committee **F08** on Sports Equipment, Playing Surfaces, and Facilities and are the direct responsibility of Subcommittee **F08.30** on Fitness Products.

Current edition approved May 15, 2017/Dec. 1, 2017. Published August 2017/January 2018. Originally approved in 2003. Last previous edition approved in 2012/2017 as **F2277 – 12**; **F2277 – 17**. DOI: [10.1520/F2277-17](https://doi.org/10.1520/F2277-17); [10.1520/F2277-17A](https://doi.org/10.1520/F2277-17A).

1.2.18 Additional universal design and construction requirements.

1.3 This test method<sup>2</sup> contains additional requirements to address the accessibility of the equipment for persons with disabilities.

1.4 The values stated in SI units are to be regarded as the standard. The values in parenthesis are for information only.

1.5 *This standard does not purport to address all of the safety concerns, if any, associated with its use. It is the responsibility of the user of this standard to establish appropriate safety, health, and health/environmental practices and determine the applicability of regulatory limitations prior to use.*

1.6 *This international standard was developed in accordance with internationally recognized principles on standardization established in the Decision on Principles for the Development of International Standards, Guides and Recommendations issued by the World Trade Organization Technical Barriers to Trade (TBT) Committee.*

## 2. Referenced Documents

2.1 *ASTM Standards:*<sup>3</sup>

[F1749 Specification for Fitness Equipment and Fitness Facility Safety Signage and Labels](#)

[F2216 Specification for Selectorized Strength Equipment](#)

[F2276 Specification for Fitness Equipment](#)

[F2571 Test Methods for Evaluating Design and Performance Characteristics of Fitness Equipment](#)

[F3022 Test Method for Evaluating the Universal Design of Fitness Equipment for Inclusive Use by Persons with Functional Limitations and Impairments](#)

## 3. Terminology

3.1 *Definitions of Terms Specific to This Standard:*

3.1.1 *normal operation, n*—the operation of the selectorized strength equipment as defined by the manufacturer.

## 4. Significance and Use

4.1 The purpose of these test methods is to provide valid and repeatable test methods for the evaluation of selectorized strength equipment assembled and maintained according to the manufacturer's specifications. Use of these test methods in conjunction with Specification [F2216](#) is intended to maximize the reliability of selectorized strength equipment design and reduce the risk of serious injury resulting from design deficiencies.

## 5. Sample Preparation

5.1 Assemble and adjust the selectorized strength equipment according to the manufacturer's instructions. Remove upholstered pads from the sample. On machines that are fully assembled, verify according to the manufacturer's instructions that all components are functioning and that they have been adjusted and aligned properly. Unless otherwise stated, the machine must pass the tests without adjustment from this initial condition. Selectorized strength equipment shall be provided with the largest weight stack offered by the manufacturer for the model to be tested.

5.2 The individual test methods will describe any variations or modifications that are required to the test sample.

## 6. Test Methods and Procedures

6.1 *Stability:*

6.1.1 Selectorized strength equipment shall be tested with and without the simulated user load in the orientation that is most obviously unstable. If the orientation that is most obviously unstable is not clear, it may be necessary to test several orientations.

6.1.2 *Apparatus and Set-Up*—Refer to [Fig. 1](#). Place sample on a non-skid surface inclined at 10° in the orientation that is least stable. The sample shall rest on the supporting surface without anchoring unless the installation instructions for the machine require that the sample be anchored to the floor. If this is the case, then anchor the specimen per the manufacturer's recommendations. Determine how the user is placed on the machine to perform the exercise (that is, seating, standing, or prone) and then determine how the user's body weight is distributed onto the user support surfaces. For the simulated use test, a method of applying a steady state load equal to 100 kg (220 lb) simulating the user's weight and its distribution in the vertical direction at the point(s) of user contact must be provided. As an example, for a seated user, the user support surface shall be adjusted to the uppermost position (if adjustable) and the center of gravity of the 100 kg (220 lb) load shall be positioned approximately 300 mm (12 in.) above the user support surface. Possible methods of providing this load include, but are not limited to, pneumatic cylinder(s) or dead weights.

6.1.3 *Calibration*—Using an angle measuring instrument accurate to within 0.1°, verify the non-skid surface is 10 ± 0.5°. Calibrate the load measurement apparatus to confirm accuracy to within ±20 N (4.5 lb) over entire 981 N (220 lb) range.

<sup>2</sup> This work was funded, in part, by the Rehabilitation Engineering Research Center on RecTech through the National Institute on Disability, Independent Living, and Rehabilitation Research grant #90RE5009-01-00.

<sup>3</sup> For referenced ASTM standards, visit the ASTM website, [www.astm.org](http://www.astm.org), or contact ASTM Customer Service at [service@astm.org](mailto:service@astm.org). For *Annual Book of ASTM Standards* volume information, refer to the standard's Document Summary page on the ASTM website.

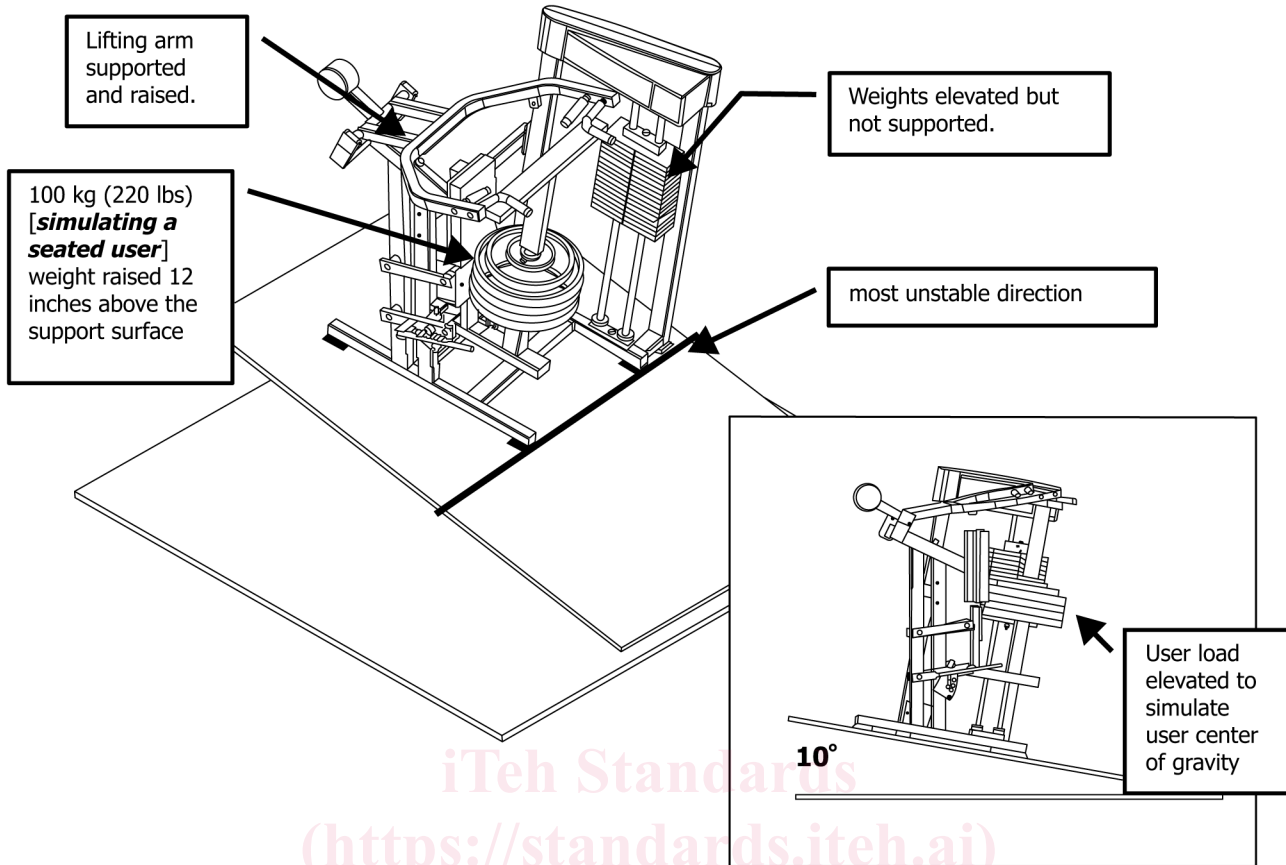

FIG. 1 Tilt Test

6.1.4 *Procedure*—Test the sample as follows:

6.1.4.1 With the sample machine (no user load applied) positioned on the tilt surface, verify that the sample does not tip over with the resistance means in the rest position.

6.1.4.2 Using the aforementioned load apparatus, distribute a vertical load equal to 100 kg (220 lb)  $\pm$  5 % in a non-impact manner to the specimen where the user contacts the machine during normal operation. (If only a portion of the user's body is supported by the machine during operation, the 100 kg (220 lb) simulated user weight shall be reduced by the appropriate amount.) Raise and support the lifting arms and weight stack to simulate the furthest point in the range of travel as encountered during normal operation of the machine by a user of 1.8 m (74 in.) stature. Verify that the sample does not tip over.

6.1.4.3 Repeat 6.1.4.1 and 6.1.4.2 with the sample oriented in any other directions of potential instability.

6.1.5 *Pass/Fail Criteria*—In none of the above test conditions shall the sample tip over.

6.1.6 *Precision and Bias*—No information is presented about either the precision or bias of test 6.1 for measuring stability since the test result is non-quantitative.

6.2 *Weight Stack Travel:*

6.2.1 This test is a visual inspection of the sample to ensure that the weight stack travels freely along its guide means and returns to its initial position after the displacing force has been removed.

6.2.2 *Apparatus and Set Up*—The sample shall be set up as described in 5.1.

6.2.3 *Calibration*—No calibration required. Visual inspection only.

6.2.4 *Procedure*—Move the lifting arm through its range of travel and verify that the weight stack moves along a guide means in a controlled manner and returns to its initial position as the lifting arm is returned to its initial rest position.

6.2.5 *Pass/Fail Criteria*—The weight stack must begin and end the test in the same rest position and must not move unless it is displaced intentionally by a lifting force applied to the lifting arm.

6.2.6 *Precision and Bias*—No information is presented about either the precision or bias of test in 6.2 for evaluating weight stack travel since the test result is non-quantitative.

6.3 *Weight Stack Selector Pin Retention:*

6.3.1 This test is a visual and physical inspection of the weight stack selector pin to ensure that the design features a retention device and that it functions properly.

6.3.2 *Apparatus and Set Up*—The sample shall be set up as described in 5.1. Obtain instructions or a descriptive explanation of the function of the weight stack selector pin from the manufacturer.

6.3.3 *Calibration*—No calibration required. Visual and function inspection only.

6.3.4 *Procedure*—Inspect the weight stack selector pin and ensure that it features a retention device that will not allow the pin to be removed from the weight stack unless it is intentionally removed. Examples of retention devices include, but are not limited to, spring activated detent balls or a physical deformation of the pin and comparable retention zone on the weight plate. The operation of the retention system shall be self-evident. Insert the weight stack selector pin into a weight on the weight stack and verify that the retention mechanism functions properly.

6.3.5 *Pass/Fail Criteria*—Weight stack selector pins that do not have a retention means shall fail this test. Retention mechanisms that do not function according to the instructions provided by the manufacturer shall fail this test.

6.3.6 *Precision and Bias*—No information is presented about either the precision or bias of test in 6.3 for evaluating weight stack selector pin design and function since the test result is non-quantitative.

#### 6.4 *Entrance/Exit from Machine:*

6.4.1 This test is a visual and physical inspection of the machine to determine whether or not an assist means is required and then ensure that the design functions properly.

6.4.2 *Apparatus and Set Up*—The sample shall be set up as described in 5.1. Reinstall the upholstered pads for this test. Obtain instructions or a descriptive explanation of the function of the assist mechanism(s) used on the sample from the manufacturer.

6.4.3 *Calibration*—No calibration required. Visual and function inspection only.

6.4.4 *Procedure*—Adjust the machine for the evaluator’s size according to the manufacturer’s instructions. The evaluator shall enter the machine and attempt to get into the exercise start position as described in the operation instructions provided by the manufacturer. The evaluator shall be able to get into and back out of the starting position with relative ease. If the lifting or user means cannot be reached by the evaluator or if the evaluator cannot get into the starting position easily, then further adjustment of the machine may be required. If this is not the case (the machine is properly adjusted per the operation instructions for the given body size of the evaluator), then an assist means that moves the lifting or user means into the direction of lifting stroke must be provided.

6.4.4.1 If an assist means is provided, then operate the mechanism and ensure that it performs as described in the operation instructions. Upon actuation of the assist means, the lifting or user means shall move into the direction of machine motion allowing the user to get into the loaded exercise start position. Upon completion of the exercise and return of the lifting or user means to the rest position, actuation of the assist means shall stop the lifting or user means prior to reaching the unloaded rest position, thereby allowing the user to exit from the loaded use position.

6.4.5 *Pass/Fail Criteria*—Machines that do not allow the user to enter or exit the machine easily shall fail the test. Assist mechanisms that do not function according to the instructions provided by the manufacturer shall fail test. Assist mechanisms that do not stop the lifting or user means far enough into the lifting stroke to allow the user to control and/or stop the final return travel of the lifting or user means shall fail the test.

6.4.6 *Precision and Bias*—No information is presented about either the precision or bias of test in 6.4 for evaluating assist mechanism design and function since the test result is non-quantitative.

#### 6.5 *Belt or Rope System Design and Load Testing:*

6.5.1 This test is a visual, physical, and functional inspection of the cables, belts, or ropes and their end fittings and attachment means used on the sample to route the load from the resistance means to the user means to ensure that the design functions as intended and meets the parameters of Specification F2216.

6.5.2 *Apparatus and Set Up*—The sample shall be set up as described in 5.1. Obtain instructions or a descriptive explanation of the function of the specimen from the manufacturer. Three cable, belt, or rope specimens measuring 150 mm (5.9 in.) replicating the system installed on sample including their attachment means shall be provided for a separate loading test.

6.5.3 *Calibration*—Calibrate the load measurement apparatus to confirm accuracy to within  $\pm 50$  N ( $\pm 11$  lb).

#### 6.5.4 *Procedure:*

6.5.4.1 *Design Evaluation*—Select the minimum resistance level for the sample. Cycle the machine through several complete repetitions while observing the rope or belt attachment points. Ensure that all end fittings and attachments move freely with the lifting and resistance means and that the rope or belt does not cyclically bend or flex around these components by more than a total amount of  $10^\circ$ , as shown in Fig. 2.

6.5.4.2 *Load Testing*—Obtain and record from the manufacturer the maximum load amount that the belt or rope system is subjected to during operation of the sample machine through its recommended range of motion. This should take into account any multiplying effects designed into the system to increase the resistance to the user. Secure a 150 mm (5.9 in.) specimen at its end fittings or attachments points into a tensile loading apparatus capable of loading the specimen with 6 times the aforementioned maximum load. The apparatus shall be capable of recording the maximum load attained during the test. Apply a load to the system equal to 6 times the maximum load stated above. Maintain this load for 5 min. If the system fails before attaining the 6 times load, record the load attained at failure. If the system attains the load but fails before the 5 min test period has expired, record the load and the amount of time at that load. Repeat the test for each of the remaining specimens.

#### 6.5.5 *Pass/Fail Criteria:*

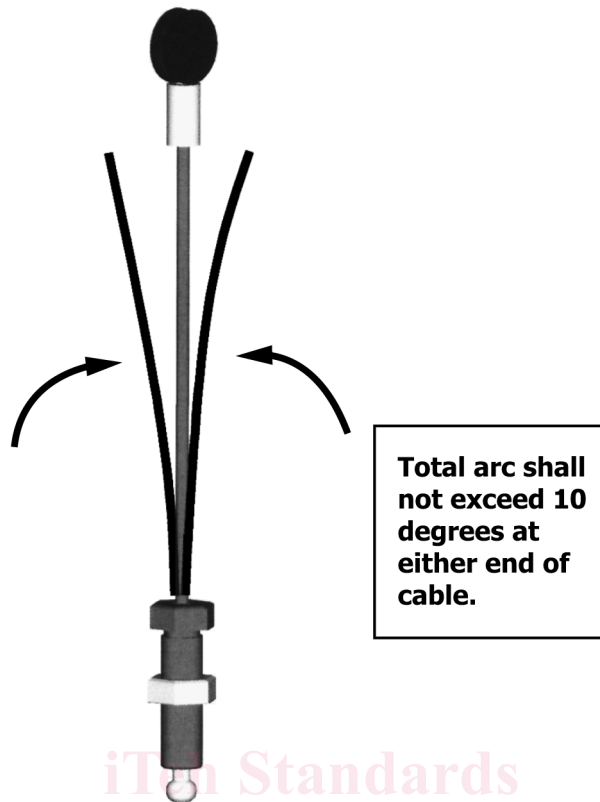

FIG. 2 Cable and Fitting Flexure

iTech Standards  
(<https://standards.itih.ai>)

6.5.5.1 *Design*—If the end fitting or termination point on a belt or rope cyclically flexes through an arc of more than 10° during normal or intended use as defined by the manufacturer in either a combined or unidirectional amount then the cable, belt, or rope system shall fail the test.

6.5.5.2 *Load Testing*—If the belt or rope system fails to attain 6 times the maximum load and fails to maintain that load for 5 min then the system shall fail the test.

6.5.6 *Precision and Bias*—No information is presented about either the precision or bias of test in 6.5 for evaluating belt or rope system design since the test result is non-quantitative.

#### 6.6 *Pulley and Pulley Enclosure Design:*

6.6.1 This test is a visual, physical, and functional inspection of the pulleys used on the sample to rout the load from the resistance means to the user means to insure that the design functions as intended and meets the parameters of Specification F2216. This test also verifies that the pulley enclosures prevent the ropes or belts from being inadvertently disengaged from the pulleys.

6.6.2 *Apparatus and Set Up*—The sample shall be set up as described in 5.1. Obtain instructions or a descriptive explanation of the function of the specimen from the manufacturer. A method of applying a force of 20 N (4.5 lb) perpendicularly to the rope or belt shall be provided.

6.6.3 *Calibration*—Calibrate the load measurement apparatus to confirm accuracy to within  $\pm 0.5$  N (0.1 lb). Verify that the measuring device is accurate to 1 mm (0.04 in.).

6.6.4 *Procedure*—Inspect and measure the pulley and verify that it falls within the parameters specified in Specification F2216 for the size wire rope being used on the machine. If the machine is belt driven, verify that the pulley is designed to prevent disengagement. Appropriate means would include convex or concave profile or retainment edges on each side of the pulley.

6.6.4.1 Examine the enclosures for the pulleys. Grasp the rope or belt as it exits/enters the enclosure and apply a pulling force of 20 N (4.5 lb) 90° to the direction of travel. The cable or belt shall not come off of the pulley. Repeat this process at other pulley locations on the machine.

6.6.4.2 Select the full resistance level of the sample and move the lifting means through one or more cycles at a slow and controlled rate of motion. The pulleys shall rotate as the lifting means is cycled.

6.6.5 *Pass/Fail Criteria*—Pulleys with dimensions falling outside of those specified in Specification F2216 shall fail test. Belt pulleys failing to feature a retention design shall fail the test. Enclosures that allow for disengagement of the cable or belt shall fail the test. Pulleys that do not rotate under full loading shall fail this test.

6.6.6 *Precision and Bias*—No information is presented about either the precision or bias of test in 6.6 for evaluating pulley and pulley enclosure design and function since the test result is non-quantitative.



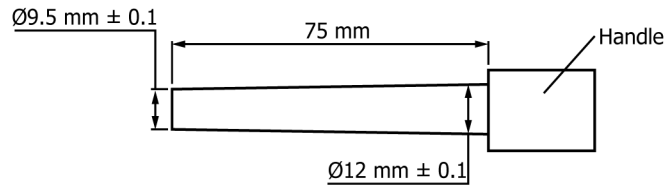

**FIG. 3 Probe Specifications**

### 6.7 Entrapment Testing:

6.7.1 This test is to evaluate the risk of injury to the user or to a third party due to inadvertent contact with a moving mechanical part and a fixed component of the machine. The results of this test determine the adequacy of spacing between components. Methodology entails insertion of a sized probe into the entrapment areas discussed in Specification F2216. It has been assumed that contact in these areas is inadvertent and therefore the test will be perpendicular and through the area in question and not articulated into all possible areas around the potential hazard.

6.7.2 *Apparatus and Set Up*—The sample shall be set up as described in 5.1 with the upholstered pads reinstalled. This test requires a probe as specified in Fig. 3.

6.7.3 This test also requires sized probes of 9.5 mm (0.38 in.) and 25 mm (0.98 in.) for areas most susceptible to finger injury and 60 mm (2.36 in.) for all other areas. Verify that all guards are properly positioned and secured. An apparatus capable of measuring 4.4 N (1 lb) of pulling force shall be provided.

6.7.4 *Calibration*—Calibrate the load measurement apparatus to confirm accuracy to within  $\pm 0.5 \text{ N}$  (0.1 lb). Verify that the probe conforms to the dimensions shown in Fig. 3. Verify that the 9.5 mm (0.37 in.) sized probe is no less than the stated size and that the other sized probes are no greater than their stated sizes.

6.7.5 *Procedure*—Refer to Specification F2216 while conducting this test. The evaluator shall place himself/herself on the sample in the operational position and determine and note regions of the sample that are to be evaluated. Areas of concern that are 1800 mm (71 in.) or more above the floor are exempt from this requirement and do not need to be examined further. Areas that are blocked by the user of the equipment throughout the range of motion are also exempt from further examination. The evaluator shall pay attention to areas outside their field of view and areas outside their reach as discussed in Specification F2216. The evaluator shall determine, for the area of concern, the portion of the body most likely to be injured and then use the appropriate probe. Insert the probe perpendicular to this area and cycle the machine through one stroke with the minimum resistance selected to verify probe entrapment. Repeat with the full amount of resistance for the area of concern. Pay close attention to the deflection of the machine and its components as this deflection may create new areas of concern. If the probe becomes entrapped, apply a pulling force to remove the probe. Record the force required to remove the probe.

6.7.6 *Pass/Fail Criteria*—The probe shall not become entrapped in any mechanical hazard. Entrapment is defined to have occurred if the force to pull out the probe is greater than 4.4 N (1 lb).

6.7.7 *Precision and Bias*—No information is presented about either the precision or bias of test in 6.7 for evaluating entrapment points outside of the field of view of the user since the test result is non-quantitative.

### 6.8 Pull-In Point Testing:

6.8.1 This test is to evaluate the risk of injury to the user or to a third party due to inadvertent contact between either rotating and fixed components of the sample or between the belts/ropes/chains of the sample and their respective cams, pulleys, or sprockets. The results of this test determine the adequacy of spacing between components or the adequacy of the guarding of those components, or both. Methodology entails insertion of a sized probe into the pull in areas discussed in Specification F2216. It has been assumed that contact in these areas is inadvertent and therefore the test will be perpendicular and through the area in question and not articulated into all possible areas around the potential hazard.

6.8.2 *Apparatus and Set Up*—The sample shall be set up as described in 5.1 with the upholstered pads reinstalled. This test requires a probe as specified in Fig. 3. This test also requires a sized probe of 25 mm (0.98 in.). Verify that all guards are properly positioned and secured. An apparatus capable of measuring 4.4 N (1 lb) of pulling force shall be provided. Pressure measuring film capable of measuring  $90 \text{ N/cm}^2$  (131 psi) shall be provided.<sup>4</sup>

6.8.3 *Calibration*—Calibrate the load measurement apparatus to confirm accuracy to within  $\pm 0.5 \text{ N}$  (0.1 lb). Verify that the probe conforms to the dimensions shown in Fig. 3. Verify that the 9.5 mm (0.37 in.) sized probe is no less than the stated size and that the other sized probes are no greater than their stated sizes.

6.8.4 *Procedure*—The evaluator shall place himself/herself on the sample in the operational position and determine and note regions of the sample that are to be evaluated. Specification F2216 must be referred to in order to determine which areas shall be evaluated. Areas of concern that are 1800 mm (71 in.) or more above the floor are exempt from this requirement and do not need to be examined further. Areas that are blocked by the user of the equipment throughout the range of motion are also

<sup>4</sup> The sole source of supply of the film (Fuji Prescale Film—single sheet type for high pressure) known to the committee at this time is Fuji Photo Film Co. Ltd, Tokyo, Japan or their distributors. If you are aware of alternative suppliers, please provide this information to ASTM International Headquarters. Your comments will receive careful consideration at a meeting of the responsible technical committee,<sup>1</sup> which you may attend.