



Designation: **D6265—15 D6265 – 17**

## Standard Practice for Separation of Contaminants in Polymers Using an Extruder Filter Test<sup>1</sup>

This standard is issued under the fixed designation D6265; the number immediately following the designation indicates the year of original adoption or, in the case of revision, the year of last revision. A number in parentheses indicates the year of last reapproval. A superscript epsilon ( $\epsilon$ ) indicates an editorial change since the last revision or reapproval.

### 1. Scope\*

1.1 This practice covers a means to separate the unmolten particles, gels, and impurities contaminating a polymer sample. The procedure may be used to remove gels and incompatible materials that may cause imperfections in the final extruded product. Under pressure, most gels will break up or deform and pass through a wire mesh filter, however high molecular weight gels may not break up or deform.

1.2 Materials isolated on a wire mesh filter can be identified by spectroscopic or other analytical means.

NOTE 1—Although not presented as a quantitative method, the procedure presented in this practice may be used to provide quantitative results at the discretion of the user. The user assumes the responsibility to verify the reproducibility of quantitative results. Detection limit depends on the mesh size of the filter screen, but the procedure is generally applicable to the separation of immiscible contaminants present at concentrations greater than 0.1 %.

1.3 The values stated in SI units are to be regarded as standard.

1.4 *This standard does not purport to address all of the safety concerns, if any, associated with its use. It is the responsibility of the user of this standard to establish appropriate safety, health, and environmental practices and determine the applicability of regulatory limitations prior to use.* For specific hazards statements, see Section 8:

NOTE 2—There is no known ISO equivalent to this standard.

NOTE 2—There is no known ISO equivalent to this standard.

1.5 *This international standard was developed in accordance with internationally recognized principles on standardization established in the Decision on Principles for the Development of International Standards, Guides and Recommendations issued by the World Trade Organization Technical Barriers to Trade (TBT) Committee.*

### 2. Referenced Documents

2.1 *ASTM Standards:*<sup>2</sup>

D1238 Test Method for Melt Flow Rates of Thermoplastics by Extrusion Plastometer

D1600 Terminology for Abbreviated Terms Relating to Plastics

~~D7209 Guide for Waste Reduction, Resource Recovery, and Use of Recycled Polymeric Materials and Products (Withdrawn 2015)~~<sup>3</sup>

IEEE/ASTM SI-10 Practice for Use of the International System of Units (SI) (the Modernized Metric System)

### 3. Terminology

3.1 The terminology used in this practice is in accordance with Terminology D1600 and Guide ~~D7209~~. Units and symbols are in accordance with Practice IEEE/ASTM SI-10.

### 4. Summary of Practice

4.1 This practice determines the relative contamination level that can cause undesirable imperfections in the extruded product due to contaminants and gels. Although this practice is not designed to provide an absolute measurement of contamination level, using appropriate criteria, the rate of this pressure rise can be correlated to the relative contamination level.

<sup>1</sup> This test method is under the jurisdiction of ASTM Committee D20 on Plastics and is the direct responsibility of Subcommittee D20.95 on Recycled Plastics. Current edition approved Oct. 1, 2015; Dec. 1, 2017. Published October 2015; January 2018. Originally approved in 1998. Last previous edition approved in 2009 as D6265 – 09; D6265 – 15. DOI: 10.1520/D6265-15.10.1520/D6265-17.

<sup>2</sup> For referenced ASTM standards, visit the ASTM website, www.astm.org, or contact ASTM Customer Service at service@astm.org. For Annual Book of ASTM Standards volume information, refer to the standard's Document Summary page on the ASTM website.

\*A Summary of Changes section appears at the end of this standard

## 5. Significance and Use

5.1 Problems with extrusion and subsequent processing of the material are caused, in part, by the presence of paper, metal, gels, incompatible polymers, or other extraneous contamination found in polymers.

## 6. Apparatus

6.1 *Extruder*, designed to deliver a continuous supply of molten resin to a filter at a uniform rate with good temperature control. Extruders with 18 to 64-mm diameters have been found to be satisfactory.

6.1.1 *Internal Rod Die*, to fix the filter area. Fig. 1 shows a typical 6.4 mm diameter die that gives a filter area of 12.45 mm<sup>2</sup>.

6.1.2 *Breaker Plate or Screen Holder*—A typical configuration is shown in Fig. 2.

6.1.3 *Pressure Transducer*, installed in-line before the screen pack and connected to digital readout.

6.1.4 *Melt Thermocouple*, installed before or after the screen pack.

6.1.5 *High Pressure Alarm and Rupture Disk*.

6.1.6 *Split Clamp*, to permit ready access to the screens, sizing die, and breaker plate.

6.1.7 *Swing Gate*, to support the split clamp (6.1.6) during screen changes.

NOTE 3—Although desirable, a swing gate is not always available on small extruders.

6.2 *Screens*, The screen diameter is equal to the barrel diameter. Screen sizes of 60 mesh (0.251-mm opening), 100 mesh (0.152-mm opening), 200 mesh (0.076-mm opening),  $\phi$ 325 mesh (0.045-mm opening) or finer have been found to be satisfactory.

NOTE 4—If the rate of pressure increase is impractical due to extremes in the contaminant level or size, screens with alternative mesh sizes can be used.

6.3 *Balance*, capable of weighing with accuracy of  $\pm 0.1$  kg-gms.

6.4 *Torque Wrench*, with ratchet drive attachment.

6.5 *Thermally Insulated Gloves*.

6.6 *Spatulas and Scrapers*, brass, assorted sizes for removing molten polymer from equipment.

6.7 *Recording/monitoring device*, to monitor and record pressure build-up and other extruder properties.

## 7. Materials

7.1 *Virgin Polymer*, free of gels and contaminants, for purging the extruder equipment.

## 8. Hazards

8.1 Hot polymer can cause serious burns. Do not stand in front of the extruder because air bubbles, excessive temperature or pressure causes hot polymer to be expelled from the extruder die.

8.2 Wear thermally insulated gloves when handling hot polymer or working directly with the heated areas of the extruder.

## 9. Procedure

9.1 Turn on the power to the extruder and turn on the feed throat cooling water.

9.2 Set extruder temperature controllers to maintain the barrel at the appropriate temperature for the polymer (see Table 1).

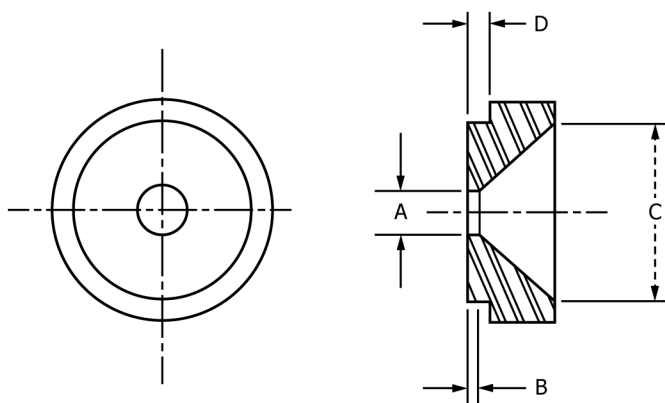

NOTE 1—A = 0.250 in.,  
 B = 0.0625 in.,  
 C = same diameter as extruder barrel, and  
 D = dimension that when added to the total thickness of the screen pack shall exceed the depth of the screen-retaining recess of the breaker plate to permit compression of the screens.

FIG. 1 Schematic Showing the Internal Sizing of the (Rod) Die