



Designation: E9 – 09 (Reapproved 2018)

Standard Test Methods of Compression Testing of Metallic Materials at Room Temperature¹

This standard is issued under the fixed designation E9; the number immediately following the designation indicates the year of original adoption or, in the case of revision, the year of last revision. A number in parentheses indicates the year of last reapproval. A superscript epsilon (ϵ) indicates an editorial change since the last revision or reapproval.

This standard has been approved for use by agencies of the U.S. Department of Defense.

1. Scope

1.1 These test methods cover the apparatus, specimens, and procedure for axial-load compression testing of metallic materials at room temperature (Note 1). For additional requirements pertaining to cemented carbides, see Annex A1.

NOTE 1—For compression tests at elevated temperatures, see Practice E209.

1.2 The values stated in inch-pound units are to be regarded as standard. The values given in parentheses are mathematical conversions to SI units that are provided for information only and are not considered standard.

1.3 *This standard does not purport to address all of the safety concerns, if any, associated with its use. It is the responsibility of the user of this standard to establish appropriate safety, health, and environmental health practices and determine the applicability of regulatory limitations prior to use.*

1.4 *This international standard was developed in accordance with internationally recognized principles on standardization established in the Decision on Principles for the Development of International Standards, Guides and Recommendations issued by the World Trade Organization Technical Barriers to Trade (TBT) Committee.*

2. Referenced Documents

2.1 ASTM Standards:²

[B557 Test Methods for Tension Testing Wrought and Cast Aluminum- and Magnesium-Alloy Products](#)

[E4 Practices for Force Verification of Testing Machines](#)

[E6 Terminology Relating to Methods of Mechanical Testing](#)

¹ These test methods are under the jurisdiction of ASTM Committee E28 on Mechanical Testing and are the direct responsibility of Subcommittee E28.04 on Uniaxial Testing.

Current edition approved Jan. 1, 2018. Published January 2018. Originally published in 1924. Last previous edition approved in 2009 as E9-09. DOI: 10.1520/E0009-09R18.

² For referenced ASTM standards, visit the ASTM website, www.astm.org, or contact ASTM Customer Service at service@astm.org. For *Annual Book of ASTM Standards* volume information, refer to the standard's Document Summary page on the ASTM website.

[E83 Practice for Verification and Classification of Extensometer Systems](#)

[E111 Test Method for Young's Modulus, Tangent Modulus, and Chord Modulus](#)

[E171/E171M Practice for Conditioning and Testing Flexible Barrier Packaging](#)

[E177 Practice for Use of the Terms Precision and Bias in ASTM Test Methods](#)

[E209 Practice for Compression Tests of Metallic Materials at Elevated Temperatures with Conventional or Rapid Heating Rates and Strain Rates](#)

[E251 Test Methods for Performance Characteristics of Metallic Bonded Resistance Strain Gages](#)

[E691 Practice for Conducting an Interlaboratory Study to Determine the Precision of a Test Method](#)

3. Terminology

3.1 *Definitions:* The definitions of terms relating to compression testing and room temperature in Terminology E6 and Practice E171/E171M, respectively, shall apply to these test methods.

3.2 *Definitions of Terms Specific to This Standard:*

3.2.1 *buckling*—In addition to compressive failure by crushing of the material, compressive failure may occur by (1) elastic instability over the length of a column specimen due to nonaxiality of loading, (2) inelastic instability over the length of a column specimen, (3) a local instability, either elastic or inelastic, over a small portion of the gage length, or (4) a twisting or torsional failure in which cross sections rotate over each other about the longitudinal specimen axis. These types of failures are all termed *buckling*.

3.2.2 *column*—a compression member that is axially loaded and that may fail by buckling.

3.2.3 *radius of gyration*—the square root of the ratio of the moment of inertia of the cross section about the centroidal axis to the cross-sectional area:

$$\rho = (I/A)^{1/2} \quad (1)$$

where:

ρ = radius of gyration,

I = moment of inertia of the cross section about centroidal axis (for specimens without lateral support, the smaller value of I is the critical value), and
 A = cross-sectional area.

3.2.4 *critical stress*—the axial uniform stress that causes a column to be on the verge of buckling. The critical load is calculated by multiplying the critical stress by the cross-section area.

3.2.5 *buckling equations*—If the buckling stress is less than or equal to the proportional limit of the material its value may be calculated using the Euler equation:

$$S_{cr} = C\pi^2 E/(L/\rho)^2 \quad (2)$$

If the buckling stress is greater than the proportional limit of the material its value may be calculated from the modified Euler equation:

$$S_{cr} = C\pi^2 E_t/(L/\rho)^2 \quad (3)$$

where:

- S_{cr} = critical buckling stress,
- E = Young's modulus,
- E_t = tangent modulus at the buckling stress,
- L = column length, and
- C = end-fixity coefficient.

Methods of calculating the critical stress using Eq 3 are given in Ref (1).³

3.2.6 *end-fixity coefficient*—There are certain ideal specimen end-fixity conditions for which theory will define the value of the constant C (see Fig. 1). These values are:

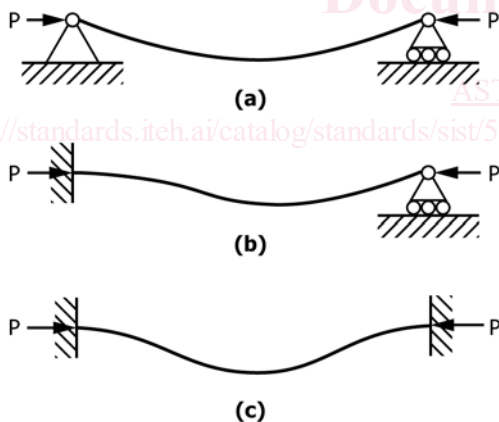

FIG. 1 Diagrams Showing Fixity Conditions and Resulting Buckling of Deformation

- Freely rotating ends (pinned or hinged) $C = 1$ (a)
- One end fixed, the other free to rotate $C = 2$ (b)
- Both ends fixed $C = 4$ (c)

NOTE 2—For flat-end specimens tested between flat rigid anvils, it was shown in Ref (1) that a value of $C = 3.75$ is appropriate.

3.2.7 *barreling*—restricted deformation of the end regions of a test specimen under compressive load due to friction at the specimen end sections and the resulting nonuniform transverse

³ The boldface numbers in parentheses refer to the list of references at the end of this standard.

deformation as shown schematically and in the photograph in Fig. 2. Additional theoretical and experimental information on barreling as illustrated in Fig. 2 is given in Ref (2).

4. Summary of Test Methods

4.1 The specimen is subjected to an increasing axial compressive load; both load and strain may be monitored either continuously or in finite increments, and the mechanical properties in compression determined.

5. Significance and Use

5.1 *Significance*—The data obtained from a compression test may include the yield strength, the yield point, Young's modulus, the stress-strain curve, and the compressive strength (see Terminology E6). In the case of a material that does not fail in compression by a shattering fracture, compressive strength is a value that is dependent on total strain and specimen geometry.

5.2 *Use*—Compressive properties are of interest in the analyses of structures subject to compressive or bending loads or both and in the analyses of metal working and fabrication processes that involve large compressive deformation such as forging and rolling. For brittle or nonductile metals that fracture in tension at stresses below the yield strength, compression tests offer the possibility of extending the strain range of the stress-strain data. While the compression test is not complicated by necking as is the tension test for certain metallic materials, buckling and barreling (see Section 3) can complicate results and should be minimized.

6. Apparatus

6.1 *Testing Machines*—Machines used for compression testing shall conform to the requirements of Practices E4. For universal machines with a common test space, calibration shall be performed in compression.

6.1.1 The bearing surfaces of the heads of the testing machine shall be parallel at all times with 0.0002 in./in. (m/m) unless an alignment device of the type described in 6.3 is used.

6.2 Bearing Blocks:

6.2.1 Both ends of the compression specimen shall bear on blocks with surfaces flat and parallel within 0.0002 in./in. (m/m). Lack of initial parallelism can be overcome by the use of adjustable bearing blocks (Note 3). The blocks shall be made of, or faced with, hard material. Current laboratory practice suggests the use of tungsten carbide when testing steel and hardened steel blocks (55 HRC or greater) and when testing nonferrous materials such as aluminum, copper, etc. The specimen must be carefully centered with respect to the testing machine heads or the subpress if used (see 6.3, Alignment Device/Subpress).

NOTE 3—The purpose of an adjustable bearing block is to give the specimen as even a distribution of initial load as possible. An adjustable bearing block cannot be relied on to compensate for any tilting of the heads that may occur during the test.

6.2.2 The bearing faces of adjustable bearing blocks that contact the specimen shall be made parallel before the load is applied to the specimen. One type of adjustable bearing block

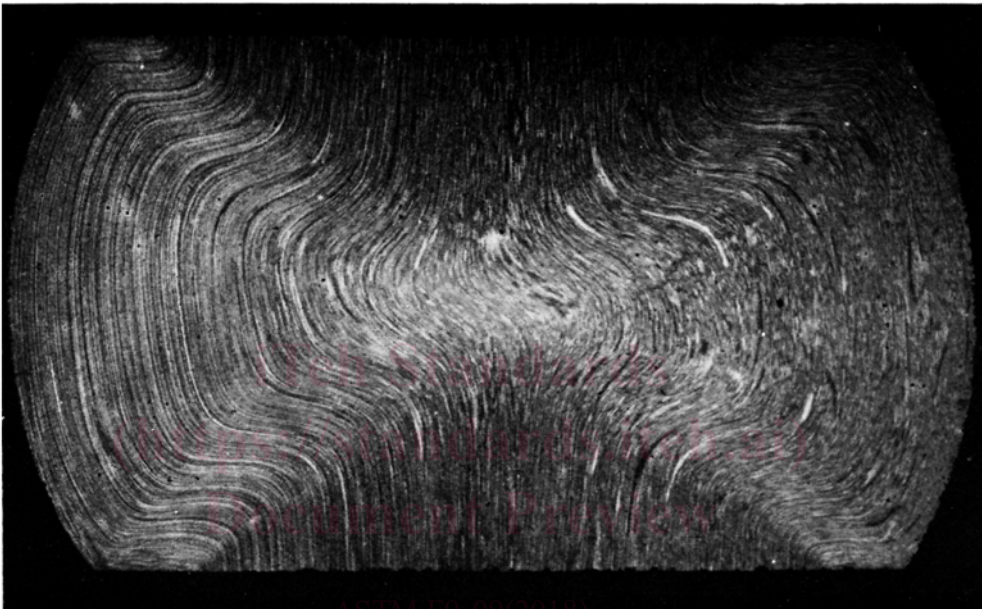
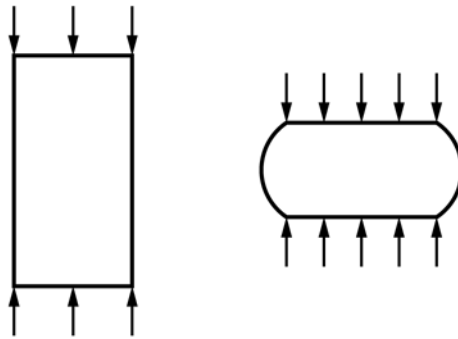

NOTE 1—A cylindrical specimen of AISI 4340 steel (HRC = 40) was compressed 57 % (see upper diagram). The photo macrograph was made of a polished and etched cross section of the tested specimen. The highly distorted flow lines are the result of friction between the specimen ends and the loading fixture. Note the triangular regions of restricted deformation at the ends and the cross-shaped zone of severe shear.

FIG. 2 Illustration of Barreling

that has proven satisfactory is illustrated in Fig. 3. Another arrangement involving the use of a spherical-seated bearing

block that has been found satisfactory for testing material other than in sheet form is shown in Fig. 4. It is desirable that the spherical-seated bearing block be at the upper end of the test specimen (for specimens tested with the load axis vertical). The spherical surface of the block shall be defined by a radius having its point of origin in the flat surface that bears on the specimen.

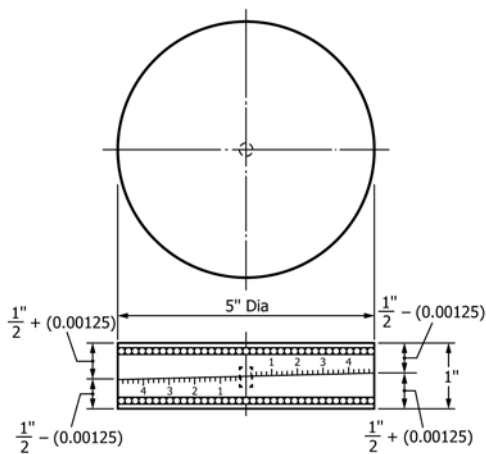

FIG. 3 Adjustable Bearing Block for Compression Testing

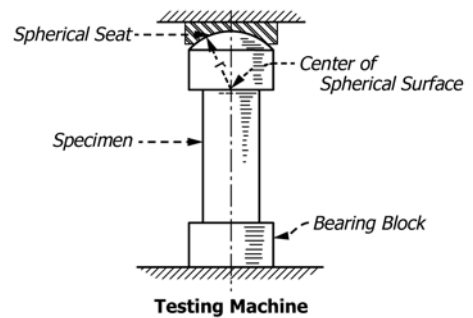

FIG. 4 Spherical-Seated Bearing Block

6.3 Alignment Device/Subpress:

6.3.1 It is usually necessary to use an alignment device, unless the testing machine has been designed specifically for axial alignment. The design of the device or subpress depends on the size and strength of the specimen. It must be designed so that the ram (or other moving parts) does not jam or tilt the device or the frame of the machine as a result of loading. The bearing blocks of the device shall have the same requirements for parallelism and flatness as given in 6.2.1.

6.3.2 The primary requirements of all alignment devices are that the load is applied axially, uniformly, and with negligible “slip-stick” friction. An alignment device that has been found suitable is shown in Fig. 5 and described in Ref. (3). Other devices of the subpress type have also been used successfully.

6.4 Compression Testing Jigs—In testing thin specimens, such as sheet material, some means should be adopted to prevent the specimen from buckling during loading. This may be accomplished by using a jig containing side-support plates that bear against the wide sides of the specimen. The jig must afford a suitable combination of lateral-support pressure and spring constant to prevent buckling, but without interfering with axial deformation of the specimen. Although suitable combinations vary somewhat with variations in specimen material and thickness, testing temperatures, and accuracy of alignment, acceptable results can be obtained with rather wide ranges of lateral-support pressure and spring constant. Generally, the higher the spring constant of the jig, the lower the lateral-support pressure that is required. Proper adjustments

of these variables should be established during the qualification of the equipment (see 6.6).

6.4.1 It is not the intent of these methods to designate specific jigs for testing sheet materials, but merely to provide a few illustrations and references to jigs that have been used successfully, some of which are cited in Table 1. Other jigs are acceptable provided they prevent buckling and pass the qualification test set forth in 6.6. Compression jigs generally require that the specimen be lubricated on the supported sides to prevent extraneous friction forces from occurring at the support points.

6.5 Strain Measurements:

6.5.1 Mechanical or electromechanical devices used for measuring strain shall comply with the requirements for the applicable class described in Practice E83. The device shall be verified in compression.

6.5.2 Electrical-resistance strain gages (or other single-use devices) may be used provided the measuring system has been verified and found to be accurate to the degree specified in Practice E83. The characteristics of electrical resistance strain gages have been determined from Test Methods E251.

6.6 Qualification of Test Apparatus—The complete compression-test apparatus, which consists of the testing machine and when applicable, one or more of the following; the alignment device, the jig and the strain-measurement system, shall be qualified as follows:

6.6.1 Conduct tests to establish the elastic modulus of five replicate specimens of 2024-T3 aluminum alloy sheet or 2024-T4 aluminum alloy bar in accordance with Test Method E111. These qualification specimens shall be machined from sheet or bar in the location specified in Test Methods B557. The thickness of the sheet or diameter of the bar may be machined to the desired thickness or diameter. It is essential that the extensometer be properly seated on the specimens when this test is performed. When the qualification specimens each provide a modulus value of 10.7×10^6 psi (73.8 GPa) $\pm 5\%$, the apparatus qualifies.

6.6.2 The qualification procedure shall be performed using the thinnest rectangular specimen or smallest diameter round specimen to be tested in the apparatus.

7. Test Specimens

7.1 Specimens in Solid Cylindrical Form—It is recommended that, where feasible, compression test specimens be in the form of solid circular cylinders. Three forms of solid cylindrical test specimens for metallic materials are recognized, and designated as short, medium-length, and long (Note 4). Suggested dimensions for solid compression test specimens for general use are given in Table 2.

NOTE 4—Short specimens typically are used for compression tests of such materials as bearing metals, which in service are used in the form of thin plates to carry load perpendicular to the surface. Medium-length specimens typically are used for determining the general compressive strength properties of metallic materials. Long specimens are best adapted for determining the modulus of elasticity in compression of metallic materials. The specimen dimensions given in Table 2 have been used successfully. Specimens with a *L/D* (length/diameter ratio) of 1.5 or 2.0 are best adapted for determining the compressive strength of high-strength materials.

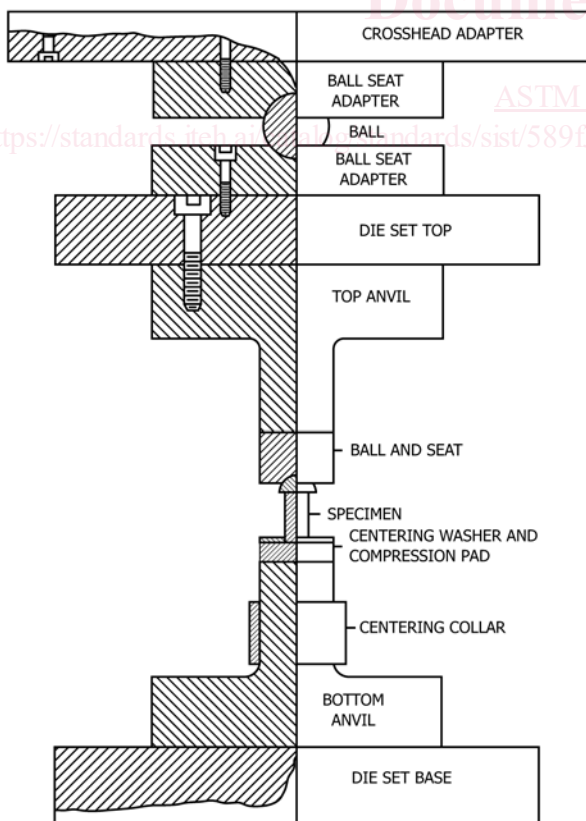

FIG. 5 Example of Compression Testing Apparatus