



Designation: C1181/C1181M – 17

Standard Test Methods for Compressive Creep of Chemical-Resistant Polymer Machinery Grouts¹

This standard is issued under the fixed designation C1181/C1181M; the number immediately following the designation indicates the year of original adoption or, in the case of revision, the year of last revision. A number in parentheses indicates the year of last reapproval. A superscript epsilon (ϵ) indicates an editorial change since the last revision or reapproval.

1. Scope*

1.1 These test methods cover a quantitative, comparative test for compressive creep of chemical-resistant grouting materials under a sustained load at a test temperature. Constant load is maintained using a bolt and spring washers. Measurements are made at laboratory temperature after exposure periods at the selected test temperature.

1.2 Test Method A outlines the molding techniques for an unbonded test specimen. Test Method B covers the molding techniques for a bonded test specimen.

1.3 The values stated in either SI units or inch-pound units are to be regarded separately as standard. The values stated in each system may not be exact equivalents; therefore, each system shall be used independently of the other. Combining values from the two systems may result in non-conformance with the standard.

1.4 *This standard does not purport to address all of the safety concerns, if any, associated with its use. It is the responsibility of the user of this standard to establish appropriate safety, health, and environmental practices and determine the applicability of regulatory limitations prior to use.*

1.5 *This international standard was developed in accordance with internationally recognized principles on standardization established in the Decision on Principles for the Development of International Standards, Guides and Recommendations issued by the World Trade Organization Technical Barriers to Trade (TBT) Committee.*

2. Referenced Documents

2.1 *ASTM Standards:*²

C904 Terminology Relating to Chemical-Resistant Nonmetallic Materials

¹ These test methods are under the jurisdiction of ASTM Committee C09 on Concrete and Concrete Aggregates and are the direct responsibility of Subcommittee C09.41 on Hydraulic Cement Grouts.

Current edition approved Dec. 15, 2017. Published January 2018. Originally approved in 1991. Last previous edition approved in 2012 as C1181 – 00 (2012). DOI: 10.1520/C1181-17.

² For referenced ASTM standards, visit the ASTM website, www.astm.org, or contact ASTM Customer Service at service@astm.org. For *Annual Book of ASTM Standards* volume information, refer to the standard's Document Summary page on the ASTM website.

3. Terminology

3.1 *Definitions*—For definitions of terms used in these test methods, see Terminology C904.

4. Significance and Use

4.1 These test methods provide a means of measuring the total compressive deflection of chemical-resistant, machinery-grout materials under a sustained load at the test temperature. Test stress and temperature can be selected to simulate anticipated use conditions. For the purposes of these tests, creep is considered to be the compressive deflection in cm per cm [inches per inch], which occurs after the initial loading of the specimen at laboratory temperature. *The results do not necessarily correlate for different specimen thicknesses.* No correlation has been established to actual-use conditions.

5. Apparatus

5.1 *Steel Loading Plates*—Steel plates, as described, are used for loading the grout during the test. They may, also, be part of the mold used to cast the grout specimen.

5.1.1 Two steel plates are required for each test specimen. The plates shall be 11 to 13 cm [4¼ to 5 in.] square by 25 mm [1 in.] thick. A 30-mm [1½-in.] diameter hole shall be drilled in the center of the plates. The edges of the plates and holes shall be deburred.

5.1.2 One of the steel plates shall have four 6-mm [¼-in.] measuring holes (one in each corner) with the center 13 mm [½ in.] in from each edge.

5.2 *Bolt Assembly*—A 25-mm [1-in.] diameter by 19 cm [7.5 in.] long, high-strength steel bolt, and nut, flat washers, and spring washers are used to maintain the test load.

5.3 *Belleville Spring Washers*—Four washers are required for each test. These shall be high carbon steel with dimensions of 2.9 by 5.7 cm [1⅛ by 2¼ in.] outside diameter by 4.0-mm [0.159-in.] thickness, with 1.0-mm [0.039-in.] dish. These washers will have an approximate spring rate of 27 300 kg/cm [153 000 lb/in.] and a rated load of 2630 kg [5793 lb] when flattened.

5.4 *Grout Mold*, suitable to cast the 10-cm [4-in.] diameter by 5 cm [2 ± 0.1 in.] thick grout specimen with a 2.9-cm [1⅛-in.] diameter center hole as shown in Fig. 1. The faces

*A Summary of Changes section appears at the end of this standard

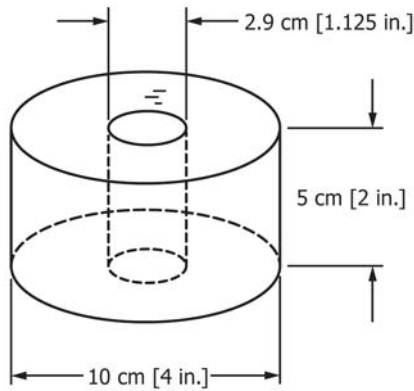

FIG. 1 Test Specimen

8. Test Procedure

8.1 Specimen Measurement:

8.1.1 Immediately following the conditioning period, measure the outside diameter of the test specimen to the nearest 25 μ [0.001 in.] using an indicating caliper. Make two measurements at right angles to one another at mid-height. Record the diameter as the average of the two measurements.

8.1.2 *Test Method A*— Using an indicating caliper, measure the thickness of the specimen in four places around the circumference to the nearest 25 μ [0.001 in.]. Record the average of the measurements as the specimen thickness. The variation in the four measurements shall not exceed 1.5 mm [0.060 in.].

8.1.3 *Test Method B*— Using an indicating caliper, measure the distance between the two plates at four places around the circumference to the nearest 25 μ [0.001 in.]. Record the average of the measurements as the specimen thickness. The variation in the four measurements shall not exceed 1.5 mm [0.060 in.].

8.2 Assemble the testing apparatus as follows:

8.2.1 Pass the bolt through the assembly consisting of a flat washer, two nested spring washers, a second flat washer, two more nested spring washers, a third flat washer, the bottom plate, the grout specimen, the top plate, a fourth flat washer, and a nut.

8.3 Calculate the load required to produce the test stress on the specimen using the following formula:

$$L = S \left(\frac{\pi D^2}{4} - A_B \right) \quad (1)$$

where:

L = total force required on a specimen, N [lb],

S = desired stress, MPa [psi],

D = diameter of the grout cylinder, mm [in.], and

A_B = area of the formed bolt hole (may be taken as 640 mm² [1 in.²]).

8.4 Place the assembly on the support stand in the compression machine or apparatus such that the load is applied directly to the bolt head and the opposite plate, leaving the nut accessible for tightening (see Fig. 2).

8.4.1 Apply and maintain the test load.

8.4.2 Tighten the nut hand-tight.

8.4.3 Release the load and remove the test fixture from the compression machine.

8.5 Immediately after removing the test apparatus from the compression machine, measure the distance between the top faces of the plates. Make the measurements to 2.5 μ [0.0001 in.] through the four corner holes, using the depth micrometer. Record the individual readings and the average of all four.

8.6 Place the specimen in the controlled temperature oven at selected temperature for the designated exposure period, then remove and allow to cool at 23 \pm 2°C [73 \pm 4°F] for at least 24 h. Reload the specimen as in 8.4; take new readings to 2.5 μ [0.0001 in.] and record, and then place specimen in the oven for the next exposure period.

8.7 Total exposure periods are shown in Table 1.

must be parallel to within 0.75 mm [0.030 in.] over the 10 cm [4-in.] diameter specimen contact area (see 5.3). The mold may utilize the steel loading plates.

5.4.1 For the bonded method, the plates are used as mold end plates.

5.5 *Compression Machine or Apparatus*, capable of applying the test load to within \pm 2.0 %.

5.6 *Depth Micrometer*, readable to 2.5 μ [0.0001 in.] with adjustable shaft length capable of reading approximately 7.6-cm [3-in.] depth.

5.7 *Indicating Caliper*, readable to 25 μ [0.001 in.].

5.8 *Constant Temperature Oven*, capable of maintaining the desired temperature \pm 2°C [\pm 4°F].

5.9 *Suitable Support Stand*, capable of supporting the test assembly when placed under compressive load.

6. Specimen Preparation

6.1 *Temperature*— Condition all grout components and molds at 23 \pm 2°C [73 \pm 4°F], for at least 24 h prior to use.

6.2 *Test Method A, Unbonded*—To prevent bonding, treat all surfaces of the mold with a suitable release agent, which will contact the material during casting.

6.3 *Test Method B, Bonded*:

6.3.1 Prior to assembly, clean to remove foreign matter such as rust, dirt, or scale from the grout contact surfaces of the two base plates.

6.3.2 To prevent bonding, treat all other surfaces of the mold which will contact the material during casting.

6.4 Mix the grout according to manufacturer's recommendations and pour, or otherwise place, through the fill hole in the mold. The grout may be consolidated with a rounded-end rod.

7. Conditioning

7.1 The specimen shall remain in the mold at least 16 h at 23 \pm 2°C [73 \pm 4°F].

7.2 Following the initial conditioning period, disassemble the mold (including the end plates if using Test Method A). Maintain the specimens at 23 \pm 2°C [73 \pm 4°F] for a total of seven days, including the time in the mold.