



Designation: **D97—17a D97 – 17b**



Designation: **15/95**

## Standard Test Method for Pour Point of Petroleum Products<sup>1</sup>

This standard is issued under the fixed designation D97; the number immediately following the designation indicates the year of original adoption or, in the case of revision, the year of last revision. A number in parentheses indicates the year of last reapproval. A superscript epsilon ( $\epsilon$ ) indicates an editorial change since the last revision or reapproval.

*This standard has been approved for use by agencies of the U.S. Department of Defense.*

### 1. Scope\*

1.1 This test method covers and is intended for use on any petroleum product.<sup>2</sup> A procedure suitable for black specimens, cylinder stock, and nondistillate fuel oil is described in 8.8. The cloud point procedure formerly part of this test method now appears as Test Method **D2500**.

1.2 Currently there is no ASTM test method for automated Test Method D97 pour point measurements.

1.3 Several ASTM test methods offering alternative procedures for determining pour points using automatic apparatus are available. None of them share the same designation number as Test Method D97. When an automatic instrument is used, the ASTM test method designation number specific to the technique shall be reported with the results. A procedure for testing the pour point of crude oils is described in Test Method **D5853**.

1.4 The values stated in SI units are to be regarded as standard. No other units of measurement are included in this standard.

1.5 **WARNING**—Mercury has been designated by many regulatory agencies as a hazardous material that can cause central nervous system, kidney and liver damage. Mercury, or its vapor, may be hazardous to health and corrosive to materials. Caution should be taken when handling mercury and mercury containing products. See the applicable product Material Safety Data Sheet (MSDS) for details and EPA's website—<http://www.epa.gov/mercury/faq.htm>—for additional information. Users should be aware that selling mercury and/or mercury containing products into your state or country may be prohibited by law.

1.6 *This standard does not purport to address all of the safety concerns, if any, associated with its use. It is the responsibility of the user of this standard to establish appropriate safety and health practices and determine the applicability of regulatory limitations prior to use.*

1.7 *This international standard was developed in accordance with internationally recognized principles on standardization established in the Decision on Principles for the Development of International Standards, Guides and Recommendations issued by the World Trade Organization Technical Barriers to Trade (TBT) Committee.*

### 2. Referenced Documents

#### 2.1 ASTM Standards:<sup>3</sup>

**D117** Guide for Sampling, Test Methods, and Specifications for Electrical Insulating Oils of Petroleum Origin

**D396** Specification for Fuel Oils

**D2500** Test Method for Cloud Point of Petroleum Products and Liquid Fuels

**D5853** Test Method for Pour Point of Crude Oils

**D6300** Practice for Determination of Precision and Bias Data for Use in Test Methods for Petroleum Products and Lubricants

**D7962** Practice for Determination of Minimum Immersion Depth and Assessment of Temperature Sensor Measurement Drift

**E1** Specification for ASTM Liquid-in-Glass Thermometers

**E644** Test Methods for Testing Industrial Resistance Thermometers

<sup>1</sup> This test method is under the jurisdiction of ASTM Committee **D02** on Petroleum Products, Liquid Fuels, and Lubricants and is the direct responsibility of Subcommittee **D02.07** on Flow Properties.

Current edition approved May 15, 2017/Dec. 15, 2017. Published May 2017/January 2018. Originally approved in 1927, replacing D47. Last previous edition approved in 2017 as **D97—17/D97 – 17a**. DOI: [10.1520/D0097-17A](https://doi.org/10.1520/D0097-17A); [10.1520/D0097-17B](https://doi.org/10.1520/D0097-17B).

In the IP, this test method is under the jurisdiction of the Standardization Committee. This test method was adopted as a joint ASTM-IP Standard in 1965.

<sup>2</sup> Statements defining this test and its significance when applied to electrical insulating oils of mineral origin will be found in Guide **D117**.

<sup>3</sup> For referenced ASTM standards, visit the ASTM website, [www.astm.org](http://www.astm.org), or contact ASTM Customer Service at [service@astm.org](mailto:service@astm.org). For *Annual Book of ASTM Standards* volume information, refer to the standard's Document Summary page on the ASTM website.

\*A Summary of Changes section appears at the end of this standard

E1137 Specification for Industrial Platinum Resistance Thermometers

E2877 Guide for Digital Contact Thermometers

2.2 Energy Institute Standards:<sup>4</sup>

Specifications for IP Standard Thermometers

### 3. Terminology

#### 3.1 Definitions:

3.1.1 *black oil, n*—lubricant containing asphaltic materials. Black oils are used in heavy-duty equipment applications, such as mining and quarrying, where extra adhesiveness is desired.

3.1.2 *cylinder stock, n*—lubricant for independently lubricated engine cylinders, such as those of steam engines and air compressors. Cylinder stock are also used for lubrication of valves and other elements in the cylinder area.

3.1.3 *digital contact thermometer (DCT), n*—an electronic device consisting of a digital display and associated temperature sensing probe.

##### 3.1.3.1 Discussion—

This device consists of a temperature sensor connected to a measuring instrument; this instrument measures the temperature-dependent quantity of the sensor, computes the temperature from the measured quantity, and provides a digital output. This digital output goes to a digital display and/or recording device that may be internal or external to the device. These devices are sometimes referred to as “digital thermometers.”

##### 3.1.3.2 Discussion—

PET is an acronym for portable electronic thermometers, a subset of digital contact thermometers (DCT).

3.1.4 *pour point, n*—in petroleum products, the lowest temperature at which movement of the test specimen is observed under prescribed conditions of test.

3.1.5 *residual fuel, n*—a liquid fuel containing bottoms remaining from crude distillation or thermal cracking; sometimes referred to as heavy fuel oil.

##### 3.1.5.1 Discussion—

Residual fuels comprise Grades 4, 5, and 6 fuel oils, as defined in Specification **D396**.

### 4. Summary of Test Method

4.1 After preliminary heating, the sample is cooled at a specified rate and examined at intervals of 3 °C for flow characteristics. The lowest temperature at which movement of the specimen is observed is recorded as the pour point.

### 5. Significance and Use

5.1 The pour point of a petroleum specimen is an index of the lowest temperature of its utility for certain applications.

### 6. Apparatus

6.1 *Test Jar*, cylindrical, of clear glass, flat bottom, 33.2 mm to 34.8 mm outside diameter, and 115 mm to 125 mm in height. The inside diameter of the jar can range from 30.0 mm to 32.4 mm, within the constraint that the wall thickness be no greater than 1.6 mm. The jar shall have a line to indicate a sample height 54 mm ± 3 mm above the inside bottom. See **Fig. 1**.

6.2 *Temperature Measuring Device*—Either liquid-in-glass thermometer as described in **6.2.1** or Digital Contact Thermometer (DCT) meeting the requirements described in **6.2.2**.<sup>5</sup>

6.2.1 *Liquid-in-Glass Thermometers*, having the following ranges and conforming to the requirements prescribed in Specification **E1** or Specifications for IP Standard Thermometers:

Thermometer	Temperature		ASTM	Thermometer Number	IP
	Range				
High cloud and pour	−38 °C to +50 °C		5C		1C
Low cloud and pour	−80 °C to +20 °C		6C		2C
Melting point	+32 °C to +127 °C		61C		63C

<sup>4</sup> Available from Energy Institute, 61 New Cavendish St., London, W1G 7AR, U.K., <http://www.energyinst.org>.

<sup>5</sup> Supporting data have been filed at ASTM International Headquarters and may be obtained by requesting Research Report RR:D02-1826. Contact ASTM Customer Service at [service@astm.org](mailto:service@astm.org).

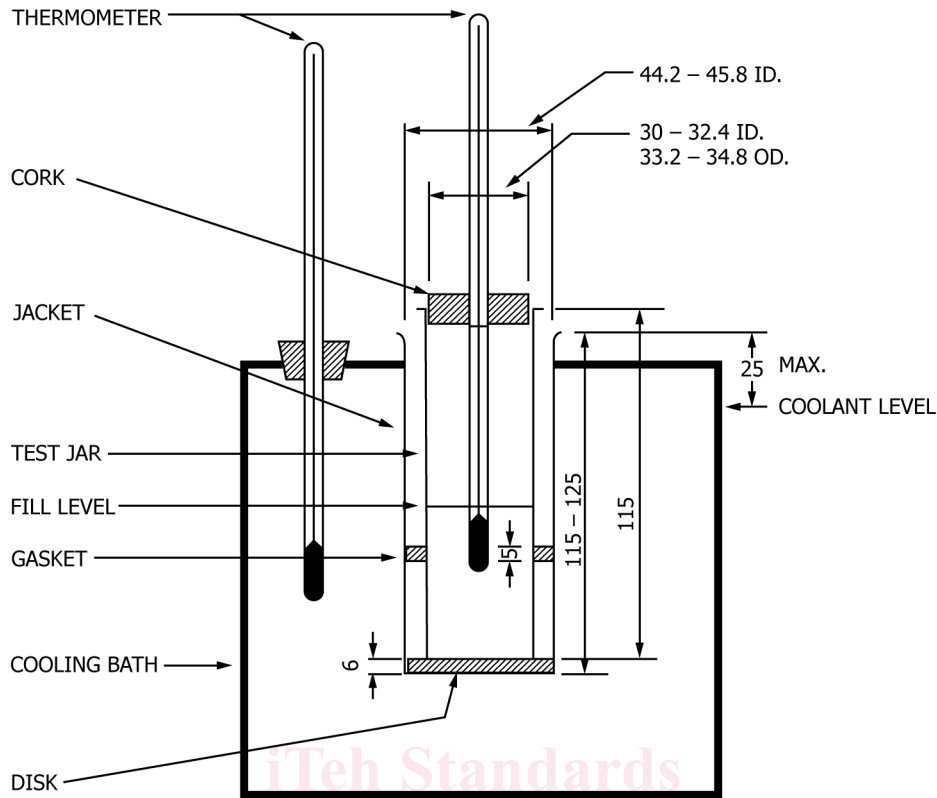

NOTE 1—Dimensions are in millimetres (not to scale).

FIG. 1 Apparatus for Pour Point Test

6.2.1.1 Since separation of liquid column thermometers occasionally occurs and may escape detection, thermometers should be checked immediately prior to the test and used only if they prove accurate within  $\pm 1^\circ\text{C}$  (for example ice point).

6.2.2 Digital Contact Thermometer Requirements:

Parameter	Requirement
DCT	Guide E2877 Class G or better
DCT	Guide E2877 Class F or better
Temperature range	$-65^\circ\text{C}$ to $90^\circ\text{C}$
Nominal temperature range <sup>A</sup>	High Pour: $-38^\circ\text{C}$ to $50^\circ\text{C}$ Low Pour: $-80^\circ\text{C}$ to $20^\circ\text{C}$ Melt Point: $32^\circ\text{C}$ to $127^\circ\text{C}$
Display resolution	0.1 $^\circ\text{C}$ minimum
Display resolution	1 $^\circ\text{C}$ minimum, preferably 0.1 $^\circ\text{C}$
Accuracy <sup>B</sup>	$\pm 500$ mK ( $\pm 0.5^\circ\text{C}$ )
Sensor type	PRT, thermistor, thermocouple
Sensor type	Platinum resistance thermometer (PRT), thermistor, thermocouple
Sensor	3 mm-OD sheath with a sensing element less than 10 mm in length
Sensor sheath <sup>C</sup>	4.2 mm OD maximum
Sensor length <sup>D</sup>	Less than 10 mm
Minimum immersion	Less than 40 mm per Test Method D7962
Immersion depth <sup>E</sup>	Less than 40 mm per Practice D7962
Sample immersion depth	Between 10 mm and 15 mm in the sample.
Sample immersion depth	Fig. 1 Tip of sheath between 10 mm and 15 mm below sample meniscus
Sample immersion depth	Fig. 1
Display accuracy	$\pm 500$ mK ( $\pm 0.5^\circ\text{C}$ ) for combined probe and sensor
Measurement drift <sup>E</sup>	Less than 500 mK (0.5 $^\circ\text{C}$ ) per year

Response time	less than or equal to 25 s as defined in Specification <b>E1137</b>
Response time <sup>F</sup>	Less than or equal to 4 s per footnote F
Drift	less than 500 mK (0.5 °C) per year
Calibration error	less than 500 mK (0.5 °C) over the range of intended use.
Calibration error	Less than 500 mK (0.5 °C) over the range of intended use
Calibration range	–40 °C or lower to 85 °C
Calibration range	Consistent with temperature range of use
Calibration data	4 data points evenly distributed over calibration range with data included in calibration report.
Calibration data	Four data points evenly distributed over the calibration range that is consistent with the range of use. The calibration data is to be included in the calibration report.
Calibration report	From a calibration laboratory with demonstrated competency in temperature calibration which is traceable to a national calibration laboratory or metrology standards body

<sup>A</sup> The nominal temperature range may be different from the values shown provided the calibration and accuracy criteria are met.

<sup>B</sup> Accuracy is the combined accuracy of the DCT unit, which is the display and sensor.

<sup>C</sup> Sensor sheath is the tube that holds the sensing element. The value is the outside diameter of the sheath segment containing the sensor element.

<sup>D</sup> The physical length of the temperature sensing element.

<sup>E</sup> As determined by Practice **D7962** or an equivalent procedure.

<sup>F</sup> **Response Time**—The time for a DCT to respond to a step change in temperature. The response time is 63.2 % of the step change time as determined per Section 9 of Test Methods **E644**. The step change evaluation begins at 20 °C ± 5 °C air to 77 °C ± 5 °C with water circulating at 0.9 m/s ± 0.09 m/s past the sensor.

NOTE 1—When making measurements below –40 °C with a PRT, it may be necessary to use a 1000 Ω sensor in order to obtain accurate measurements.

NOTE 2—When the DCT display is mounted on the end to the probe's sheath, the test jar with the probe inserted will be unstable. To resolve this, it is recommended that the probe be less than 30 cm in length but no less than 15 cm. A 5 cm long stopper, that has a low thermal conductivity, with approximately half of it inserted in the sample tube will improve stability.

6.2.2.1 The DCT calibration drift shall be checked at least annually by either measuring the ice point or against a reference thermometer in a constant temperature bath at the prescribed immersion depth to ensure compliance with 6.2.2. See Test Method Practice **D7962**.

NOTE 3—When a DCT's calibration drifts in one direction over several calibration checks, that is, ice point, it may be an indication of deterioration of the DCT.

6.3 *Cork*, to fit the test jar, bored centrally for the test temperature measuring device.

6.4 *Jacket*, watertight, cylindrical, metal, flat-bottomed, 115 mm ± 3 mm depth, with inside diameter of 44.2 mm to 45.8 mm. It shall be supported in a vertical position in the cooling bath (see 6.7) so that not more than 25 mm projects out of the cooling medium, and shall be capable of being cleaned.

6.5 *Disk*, cork or felt, 6 mm thick to fit loosely inside the jacket.

6.6 *Gasket Ring Form*, about 5 mm in thickness, to fit snugly around the outside of the test jar and loosely inside the jacket. The gasket may be made of rubber, leather, or other material that is elastic enough to cling to the test jar and hard enough to hold its shape. Its purpose is to prevent the test jar from touching the jacket.

6.7 *Bath or Baths*, maintained at prescribed temperatures with a firm support to hold the jacket vertical. The required bath temperatures may be obtained by refrigeration if available, otherwise by suitable cooling mixtures. Cooling mixtures commonly used for bath temperatures down to those shown are in **Table 1**.

## 7. Reagents and Materials

7.1 The following solvents of technical grade are appropriate for low-temperature bath media.

7.1.1 *Acetone*, (**Warning**—Extremely flammable).

7.1.2 *Alcohol, Ethanol* (**Warning**—Flammable).

7.1.3 *Alcohol, Methanol* (**Warning**—Flammable. Vapor harmful).

7.1.4 *Petroleum Naphtha*, (**Warning**—Combustible. Vapor harmful).

7.1.5 *Solid Carbon Dioxide*, (**Warning**—Extremely cold –78.5 °C).

## 8. Procedure

8.1 Pour the specimen into the test jar to the level mark. When necessary, heat the specimen in a bath until it is just sufficiently fluid to pour into the test jar.

NOTE 4—It is known that some materials, when heated to a temperature higher than 45 °C during the preceding 24 h, do not yield the same pour point results as when they are kept at room temperature for 24 h prior to testing. Examples of materials which are known to show sensitivity to thermal history are residual fuels, black oils, and cylinder stocks.