



Designation: **D5853—17 D5853 – 17a**



Designation: **441/99 (2004)**

Standard Test Method for Pour Point of Crude Oils¹

This standard is issued under the fixed designation D5853; the number immediately following the designation indicates the year of original adoption or, in the case of revision, the year of last revision. A number in parentheses indicates the year of last reapproval. A superscript epsilon (ϵ) indicates an editorial change since the last revision or reapproval.

1. Scope*

1.1 This test method covers two procedures for the determination of the pour point temperatures of crude oils down to $-36\text{ }^{\circ}\text{C}$. Procedure A provides a measure of the maximum (upper) pour point temperature and is described in 9.1. Procedure B provides a measure of the minimum (lower) pour point temperature and is described in 9.2.

1.2 The use of this test method is limited to use for crude oils. Pour point temperatures of other petroleum products can be determined by Test Method D97.

1.3 The values stated in SI units are to be regarded as standard. No other units of measurement are included in this standard.

1.4 **WARNING**—Mercury has been designated by many regulatory agencies as a hazardous material that can cause central nervous system, kidney, and liver damage. Mercury, or its vapor, may be hazardous to health and corrosive to materials. Caution should be taken when handling mercury and mercury-containing products. See the applicable product Material Safety Data Sheet (MSDS) for details and EPA's website—<http://www.epa.gov/mercury/faq.htm>—for additional information. Users should be aware that selling mercury and/or mercury containing products in your state or country may be prohibited by law.

1.5 *This standard does not purport to address all of the safety concerns, if any, associated with its use. It is the responsibility of the user of this standard to establish appropriate safety, health, and environmental practices and determine the applicability of regulatory limitations prior to use.* For specific hazard statements, see Section 7.

1.6 *This international standard was developed in accordance with internationally recognized principles on standardization established in the Decision on Principles for the Development of International Standards, Guides and Recommendations issued by the World Trade Organization Technical Barriers to Trade (TBT) Committee.*

2. Referenced Documents

2.1 *ASTM Standards:*²

D97 Test Method for Pour Point of Petroleum Products

D130 Test Method for Corrosiveness to Copper from Petroleum Products by Copper Strip Test

D323 Test Method for Vapor Pressure of Petroleum Products (Reid Method)

D4057 Practice for Manual Sampling of Petroleum and Petroleum Products

D4177 Practice for Automatic Sampling of Petroleum and Petroleum Products

D7962 Practice for Determination of Minimum Immersion Depth and Assessment of Temperature Sensor Measurement Drift

E1 Specification for ASTM Liquid-in-Glass Thermometers

E77 Test Method for Inspection and Verification of Thermometers

E1137E644 Specification—Test Methods for Testing Industrial Platinum-Resistance Thermometers

E2251 Specification for Liquid-in-Glass ASTM Thermometers with Low-Hazard Precision Liquids

E2877 Guide for Digital Contact Thermometers

3. Terminology

3.1 *Definitions of Terms Specific to This Standard:*

¹ This test method is under the jurisdiction of ASTM Committee D02 on Petroleum Products, Liquid Fuels, and Lubricants and is the direct responsibility of Subcommittee D02.07 on Flow Properties.

Current edition approved May 1, 2017 Dec. 15, 2017. Published May 2017 February 2018. Originally approved in 1995. Last previous edition approved in 2016 2017 as D5853—16 D5853 – 17. DOI: 10.1520/D5853-17-10.1520/D5853-17A.

² For referenced ASTM standards, visit the ASTM website, www.astm.org, or contact ASTM Customer Service at service@astm.org. For *Annual Book of ASTM Standards* volume information, refer to the standard's Document Summary page on the ASTM website.

*A Summary of Changes section appears at the end of this standard

3.1.1 *digital contact thermometer (DCT), n*—an electronic device consisting of a digital display and associated temperature sensing probe.

3.1.1.1 *Discussion*—

This device consists of a temperature sensor connected to a measuring instrument; this instrument measures the temperature-dependent quantity of the sensor, computes the temperature from the measured quantity, and provides a digital output. This digital output goes to a digital display and/or recording device that may be internal or external to the device. These devices are sometimes referred to as a “digital thermometer.”

3.1.1.2 *Discussion*—

PET is an acronym for portable electronic thermometers, a subset of digital contact thermometers (DCT).

3.1.2 *maximum (upper) pour point, n*—the pour point obtained after the test specimen has been subjected to a prescribed treatment designed to enhance gelation of wax crystals and solidification of the test specimen.

3.1.3 *minimum (lower) pour point, n*—the pour point obtained after the test specimen has been subjected to a prescribed treatment designed to delay gelation of wax crystals and solidification of the test specimen.

3.1.4 *pour point, n*—the lowest temperature at which movement of the test specimen is observed under the conditions of the test.

4. Summary of Test Method

4.1 After preliminary heating, the test specimen is cooled at a specified rate and examined at intervals of 3 °C for flow characteristics. The lowest temperature at which movement of the test specimen is observed is recorded as the pour point.

5. Significance and Use

5.1 The pour point of a crude oil is an index of the lowest temperature of handleability for certain applications.

5.2 This is the only pour point method specifically designed for crude oils.

5.3 The maximum and minimum pour point temperatures provide a temperature window where a crude oil, depending on its thermal history, might appear in the liquid as well as the solid state.

5.4 The test method can be used to supplement other measurements of cold flow behavior. It is especially useful for the screening of the effect of wax interaction modifiers on the flow behavior of crude oils.

6. Apparatus

6.1 *Pour Point Test Apparatus Assembly (see Fig. 1):*

6.1.1 *Test Jar*, cylindrical, of clear glass, flat bottomed, outside diameter 33.2 mm to 34.8 mm, and height 115 mm to 125 mm. The inside diameter of the jar can range from 30.0 mm to 32.4 mm, within the constraint that the wall thickness shall be no greater than 1.6 mm. The jar shall have a line to indicate a sample height 54 mm ± 3 mm above the inside bottom. The inside of the test jar (up to the mark) shall be visibly clean and free of scratches.

6.1.2 *Temperature Measuring Device*—Either liquid-in-glass thermometer as described in 6.1.2.1 or digital contact thermometer (DCT) meeting the requirements described in 6.1.2.3 and 6.1.2.4.

6.1.2.1 *Liquid-in-Glass Thermometers*, having ranges shown in the following table and conforming to the requirements prescribed in Specification E1 or Specification E2251 for thermometers:

Thermometer	Temperature Range	Thermometer	
		ASTM	Number
High cloud and pour	−38 °C to +50 °C	5C, S5C	1C
Low cloud and pour	−80 °C to +20 °C	6C	2C
Melting point	+32 °C to +127 °C	61C	63C

6.1.2.2 Since separation of liquid column thermometers occasionally occurs and may escape detection, the ice point of the thermometers shall be checked prior to the test and used only if they are accurate within ±1 °C (see Test Method E77).

6.1.2.3 *Digital Contact Thermometer Requirements for Pour Point:* Digital contact thermometer requirements for pour point:³

Parameter	Requirement
BGT	Guide E2877 Class G or better

³ Supporting data have been filed at ASTM International Headquarters and may be obtained by requesting Research Report RR:D02-1826. Contact ASTM Customer Service at service@astm.org.

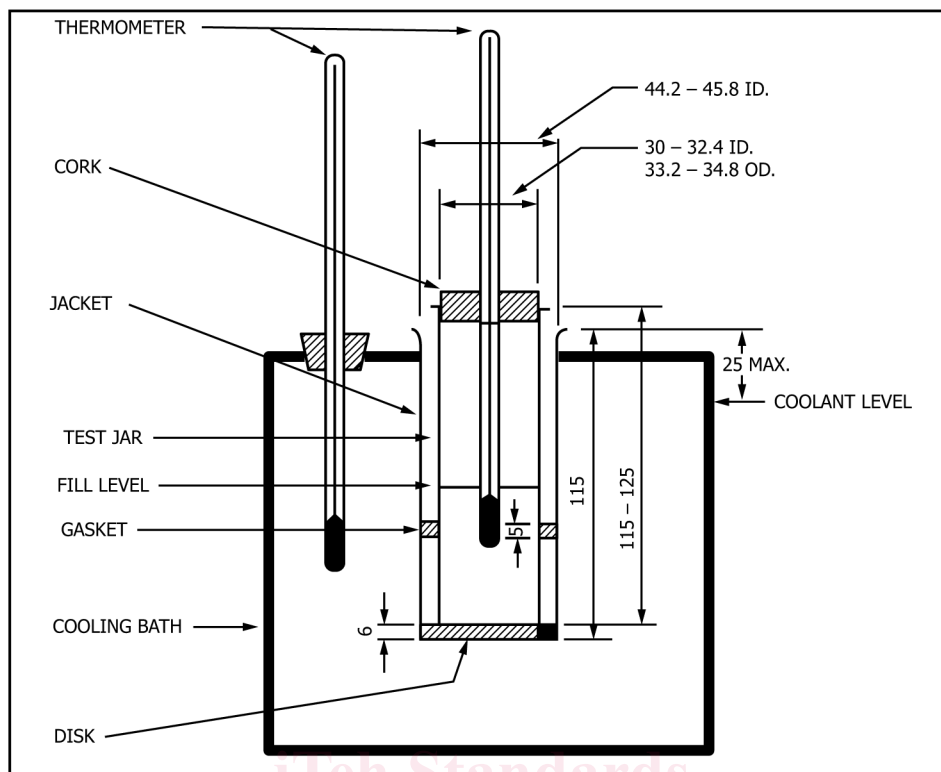

NOTE 1—All dimensions are stated in millimetres. Positioning of temperature sensing devices are shown in the figure.

FIG. 1 Apparatus for Pour Point Test

DCT	Guide E2877 Class F or better
Temperature Range Nominal temperature range ^A	–80 °C to 50 °C High Pour: –38 °C to 50 °C Low Pour: –80 °C to 20 °C Melt Point: 32 °C to 127 °C
Display Resolution Display resolution	0.1 °C minimum 0.1 °C minimum
Accuracy ^B	±500 mK (±0.5 °C)
Sensor Type Sensor type	Platinum Resistance Thermometer (PRT) Platinum resistance thermometer (PRT)
Sensor Sensor sheath ^C	3 mm o.d. sheath with a sensing element less than 10 mm in length 4.2 mm OD maximum
Sensor length ^D	Less than 10 mm
Minimum Immersion Immersion depth ^E	Less than 40 mm per Practice D7962 Less than 40 mm per Practice D7962
Length of Sheath in Sample	Tip of sheath between 10 mm and 15 mm below sample meniscus (Fig. 1):
Sample immersion depth	Tip of sheath between 10 mm and 15 mm below sample meniscus Fig. 1
Accuracy Measurement drift ^E	±500 mK (±0.5 °C) for combined probe and sensor Less than 500 mK (0.5 °C) per year
Response Time Response time ^F	Less than or equal to 25 s as defined in Specification E1137 Less than or equal to 4 s per footnote F
Drift	Less than 500 mK (0.5 °C) per year
Calibration Error	Less than 500 mK (0.5 °C) over the range of intended use.

Calibration error	Less than 500 mK (0.5 °C) over the range of intended use
Calibration Range Calibration range	–40 °C or lower to 50 °C Consistent with temperature range of use
Calibration Data Calibration data	4 data points evenly distributed over calibration range with data included in calibration report. Four data points evenly distributed over the calibration range that is consistent with the range of use. The calibration data is to be included in the calibration report.
Calibration Report Calibration report	From a calibration laboratory with demonstrated competency in temperature calibration which is traceable to a national calibration laboratory or metrology standards body. From a calibration laboratory with demonstrated competency in temperature calibration which is traceable to a national calibration laboratory or metrology standards body

^A The nominal temperature range may be different from the values shown provided the calibration and accuracy criteria are met.

^B Accuracy is the combined accuracy of the DCT unit, which is the display and sensor.

^C Sensor sheath is the tube that holds the sensing element. The value is the outside diameter of the sheath segment containing the sensor element.

^D The physical length of the temperature sensing element.

^E As determined by Practice D7962 or an equivalent procedure.

^F **Response Time**—The time for a DCT to respond to a step change in temperature. The response time is 63.2 % of the step change time as determined per Section 9 of Test Methods E644. The step change evaluation begins at 20 °C ± 5 °C air to 77 °C ± 5 °C with water circulating at 0.9 m/s ± 0.09 m/s past the sensor.

6.1.2.4 Digital contact thermometer requirements for melting point:

Parameter	Requirement
DCT	Guide E2877 Class E or better
Temperature Range	32 °C to 130 °C
Display Resolution	0.1 °C minimum
Sensor Type	Platinum Resistance Thermometer (PRT)
Sensor	3 mm o.d. sheath with a sensing element less than 24 mm in length
Minimum Immersion	Less than 40 mm per Practice D7962
Length of Sheath in Sample	Tip of sheath between 10 mm and 15 mm below sample meniscus (Fig. 1).
Accuracy	±500 mK (±0.5 °C) for combined probe and sensor
Response Time	Less than or equal to 25 s as defined in Specification E1137
Drift	Less than 500 mK (0.5 °C) per year
Calibration Error	Less than 500 mK (0.5 °C) over the range of intended use.
Calibration Range	32 °C or lower to 130 °C
Calibration Data	4 data points evenly distributed over calibration range with data included in calibration report.
Calibration Report	From a calibration laboratory with demonstrated competency in temperature calibration which is traceable to a national calibration laboratory or metrology standards body.

NOTE 1—When the DCT display is mounted on the end to the probe's sheath, the test jar with the probe inserted will be unstable. To resolve this, it is recommended that the probe be between 15 cm and 30 cm in length. A 5 cm long stopper that has a low thermal conductivity with approximately half of it inserted in the sample tube will improve stability.

NOTE 1—When making measurements below –40 °C with a PRT, it may be necessary to use a 1000 Ω sensor in order to obtain accurate measurements.

NOTE 2—When the DCT display is mounted on the end to the probe's sheath, the test jar with the probe inserted will be unstable. To resolve this, it is recommended that the probe be between 15 cm and 30 cm in length. A 5 cm long stopper that has a low thermal conductivity with approximately half of it inserted in the sample tube will improve stability.

6.1.2.4 The DCT calibration drift shall be checked at least annually by either measuring the ice point or against a reference thermometer in a constant temperature bath at the prescribed immersion depth to ensure compliance with 6.1.2.3 or 6.1.2.4. See Practice D7962.

NOTE 3—When a DCT's calibration drifts in one direction over several calibration checks, it is an indication of a change in the DCT, thus a full recalibration is necessary.

6.1.3 *Cork*, to fit the test jar, center bored for the test thermometer.

6.1.4 *Jacket*, watertight, cylindrical, metal, flat bottomed, 115 mm ± 3 mm depth, with inside diameter of 44.2 mm to 45.8 mm. It shall be supported in a vertical position in the cooling bath (6.1.7) so that no more than 25 mm projects out of the cooling medium. The jacket shall be capable of being cleaned.

6.1.5 *Disk*, cork or felt, 6 mm thick to fit loosely inside the jacket.

6.1.6 *Gasket*, to fit snugly around the outside of the test jar and loosely inside the jacket. The gasket shall be made of rubber, leather, or other material that is sufficiently elastic to cling to the test jar and hard enough to hold its shape. Its purpose is to prevent the test jar from touching the jacket.

6.1.7 *Cooling Bath or Baths*, of a type suitable for obtaining the required temperatures. The size and shape of the bath are optional, but a support to hold the jacket firmly in a vertical position is essential. The bath temperature shall be monitored by means of the appropriate thermometer (6.1.2) or any other temperature measuring device capable of measuring and displaying the designated temperature with the required precision and accuracy. The required bath temperatures shall either be obtained by refrigeration or by suitable cooling mixtures and shall maintain the designated temperatures to within ± 1.5 °C. Cooling mixtures commonly used for bath temperatures are shown in Table 1.

6.2 *Water Bath*—The size and shape of the bath are optional, but a support to hold the test jar immersed in the bath to above the sample height in the test jar and in a firm vertical position is required. The required bath temperature may be maintained by any suitable means, provided the temperature can be monitored and controlled to the designated temperature (± 1 °C (9.1.4; 9.2.4)).

6.3 *Pressure Vessel*, constructed of stainless steel according to the dimensions given in Fig. 2, and capable of withstanding a test pressure of 700 kPa. Alternative designs for the pressure vessel cap and synthetic rubber gasket may be used provided that the internal dimensions of the pressure vessel are the same as those shown in Fig. 2.

NOTE 4—This pressure vessel is identical to the pressure vessel described in Test Method D130.

6.4 *Timing Device*, capable of measuring up to 30 s with a resolution of at least 0.1 s and an accuracy of ± 0.2 s or better.

7. Reagents and Materials

7.1 The following solvents of technical grade are appropriate for low-temperature bath media.

7.1.1 *Acetone*, (**Warning**—Extremely flammable.)

7.1.2 *Petroleum Naphtha*, (**Warning**—Combustible. Vapor harmful.)

NOTE 5—Typical petroleum naphtha used for cleaning purposes are VM and P naphthas.

7.2 *Toluene*, technical grade (**Warning**—Flammable. Vapor harmful.).

7.3 *Solid Carbon Dioxide*, (**Warning**—Extremely cold (-78.5 °C).)

7.4 *Sodium Chloride Crystals*—Commercial or technical grade sodium chloride is suitable.

7.5 *Ethanol or Ethyl Alcohol*—A commercial or technical grade of dry ethanol is suitable for the cooling bath. (**Warning**—Flammable. Denatured. Cannot be made nontoxic.)

7.6 *Methanol or Methyl Alcohol*—A commercial or technical grade of dry methanol is suitable for the cooling bath. (**Warning**—Flammable. Vapor harmful.)

8. Sampling, Test Samples, and Test Specimens

NOTE 6—Sampling is defined as all steps required to obtain a portion of the contents of any pipe, tank, or other system and to place the sample into the laboratory test container.

8.1 *Laboratory Sample*—It is essential that the sample received by the laboratory is representative of the batch or lot of crude oil from which it was taken. Practices D4057 and D4177 provide guidance for obtaining such representative samples.

TABLE 1 Cooling Mixtures and Bath Temperatures

	Bath Temperature
Ice and water	0 °C \pm 1.5°C
Crushed ice and sodium chloride crystals or Acetone or petroleum naphtha or methanol or ethanol (see Section 7) with solid carbon dioxide added to give the desired temperature	-18 °C \pm 1.5°C
Acetone or petroleum naphtha or methanol or ethanol (see Section 7) with solid carbon dioxide added to give the desired temperature	-33 °C \pm 1.5°C
Acetone or petroleum naphtha or methanol or ethanol (see Section 7) with solid carbon dioxide added to give the desired temperature	-51 °C \pm 1.5°C
Acetone or petroleum naphtha or methanol or ethanol (see Section 7) with solid carbon dioxide added to give the desired temperature	-69 °C \pm 1.5°C

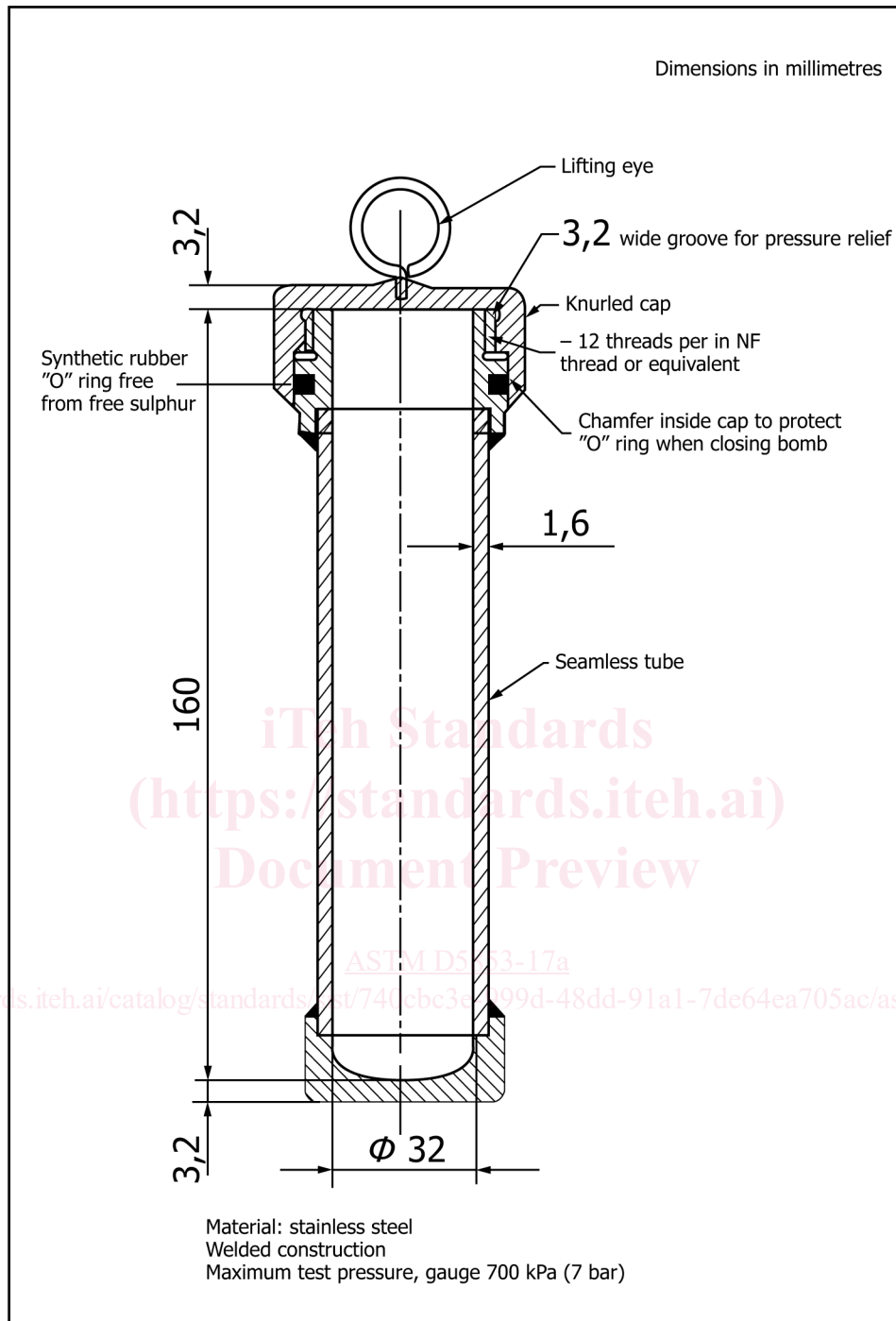

FIG. 2 Pressure Vessel

8.2 *Preparation of Test Samples*—The pour point of crude oils is very sensitive to trace amounts of high melting waxes. Exercise meticulous care to ensure such waxes, if present, are either completely melted or, if volatility constraints prevent heating to complete melting, homogeneously suspended in the sample (Appendix X1). Inspect the walls of the original container to ensure that no high melting point material is left sticking to the wall.

NOTE 7—It is not possible to define universal mandatory rules for the preparation of crude oil test samples. Guidelines for sample handling for the most common situations are given in Appendix X1.

9. Procedure

9.1 Procedure A for Maximum (Upper) Pour Point: