



Designation: D5853 – 17a



Designation: 441/99 (2004)

Standard Test Method for Pour Point of Crude Oils¹

This standard is issued under the fixed designation D5853; the number immediately following the designation indicates the year of original adoption or, in the case of revision, the year of last revision. A number in parentheses indicates the year of last reapproval. A superscript epsilon (ϵ) indicates an editorial change since the last revision or reapproval.

1. Scope*

1.1 This test method covers two procedures for the determination of the pour point temperatures of crude oils down to $-36\text{ }^{\circ}\text{C}$. Procedure A provides a measure of the maximum (upper) pour point temperature and is described in 9.1. Procedure B provides a measure of the minimum (lower) pour point temperature and is described in 9.2.

1.2 The use of this test method is limited to use for crude oils. Pour point temperatures of other petroleum products can be determined by Test Method D97.

1.3 The values stated in SI units are to be regarded as standard. No other units of measurement are included in this standard.

1.4 **WARNING**—Mercury has been designated by many regulatory agencies as a hazardous material that can cause central nervous system, kidney, and liver damage. Mercury, or its vapor, may be hazardous to health and corrosive to materials. Caution should be taken when handling mercury and mercury-containing products. See the applicable product Material Safety Data Sheet (MSDS) for details and EPA's website—<http://www.epa.gov/mercury/faq.htm>—for additional information. Users should be aware that selling mercury and/or mercury containing products in your state or country may be prohibited by law.

1.5 *This standard does not purport to address all of the safety concerns, if any, associated with its use. It is the responsibility of the user of this standard to establish appropriate safety, health, and environmental practices and determine the applicability of regulatory limitations prior to use.* For specific hazard statements, see Section 7.

1.6 *This international standard was developed in accordance with internationally recognized principles on standardization established in the Decision on Principles for the Development of International Standards, Guides and Recom-*

mendations issued by the World Trade Organization Technical Barriers to Trade (TBT) Committee.

2. Referenced Documents

2.1 ASTM Standards:²

- D97 Test Method for Pour Point of Petroleum Products
- D130 Test Method for Corrosiveness to Copper from Petroleum Products by Copper Strip Test
- D323 Test Method for Vapor Pressure of Petroleum Products (Reid Method)
- D4057 Practice for Manual Sampling of Petroleum and Petroleum Products
- D4177 Practice for Automatic Sampling of Petroleum and Petroleum Products
- D7962 Practice for Determination of Minimum Immersion Depth and Assessment of Temperature Sensor Measurement Drift
- E1 Specification for ASTM Liquid-in-Glass Thermometers
- E77 Test Method for Inspection and Verification of Thermometers
- E644 Test Methods for Testing Industrial Resistance Thermometers
- E2251 Specification for Liquid-in-Glass ASTM Thermometers with Low-Hazard Precision Liquids
- E2877 Guide for Digital Contact Thermometers

3. Terminology

3.1 Definitions of Terms Specific to This Standard:

3.1.1 *digital contact thermometer (DCT), n*—an electronic device consisting of a digital display and associated temperature sensing probe.

3.1.1.1 *Discussion*—This device consists of a temperature sensor connected to a measuring instrument; this instrument measures the temperature-dependent quantity of the sensor, computes the temperature from the measured quantity, and provides a digital output. This digital output goes to a digital display and/or recording device that may be internal or external

¹ This test method is under the jurisdiction of ASTM Committee D02 on Petroleum Products, Liquid Fuels, and Lubricants and is the direct responsibility of Subcommittee D02.07 on Flow Properties.

Current edition approved Dec. 15, 2017. Published February 2018. Originally approved in 1995. Last previous edition approved in 2017 as D5853 – 17. DOI: 10.1520/D5853-17A.

² For referenced ASTM standards, visit the ASTM website, www.astm.org, or contact ASTM Customer Service at service@astm.org. For *Annual Book of ASTM Standards* volume information, refer to the standard's Document Summary page on the ASTM website.

*A Summary of Changes section appears at the end of this standard

to the device. These devices are sometimes referred to as a “digital thermometer.”

3.1.1.2 *Discussion*—PET is an acronym for portable electronic thermometers, a subset of digital contact thermometers (DCT).

3.1.2 *maximum (upper) pour point, n*—the pour point obtained after the test specimen has been subjected to a prescribed treatment designed to enhance gelation of wax crystals and solidification of the test specimen.

3.1.3 *minimum (lower) pour point, n*—the pour point obtained after the test specimen has been subjected to a prescribed treatment designed to delay gelation of wax crystals and solidification of the test specimen.

3.1.4 *pour point, n*—the lowest temperature at which movement of the test specimen is observed under the conditions of the test.

4. Summary of Test Method

4.1 After preliminary heating, the test specimen is cooled at a specified rate and examined at intervals of 3 °C for flow characteristics. The lowest temperature at which movement of the test specimen is observed is recorded as the pour point.

5. Significance and Use

5.1 The pour point of a crude oil is an index of the lowest temperature of handleability for certain applications.

5.2 This is the only pour point method specifically designed for crude oils.

5.3 The maximum and minimum pour point temperatures provide a temperature window where a crude oil, depending on its thermal history, might appear in the liquid as well as the solid state.

5.4 The test method can be used to supplement other measurements of cold flow behavior. It is especially useful for the screening of the effect of wax interaction modifiers on the flow behavior of crude oils.

6. Apparatus

6.1 *Pour Point Test Apparatus Assembly (see Fig. 1):*

6.1.1 *Test Jar*, cylindrical, of clear glass, flat bottomed, outside diameter 33.2 mm to 34.8 mm, and height 115 mm to 125 mm. The inside diameter of the jar can range from 30.0 mm to 32.4 mm, within the constraint that the wall thickness shall be no greater than 1.6 mm. The jar shall have a line to indicate a sample height 54 mm ± 3 mm above the inside bottom. The inside of the test jar (up to the mark) shall be visibly clean and free of scratches.

6.1.2 *Temperature Measuring Device*—Either liquid-in-glass thermometer as described in 6.1.2.1 or digital contact thermometer (DCT) meeting the requirements described in 6.1.2.3.

6.1.2.1 *Liquid-in-Glass Thermometers*, having ranges shown in the following table and conforming to the requirements prescribed in Specification E1 or Specification E2251 for thermometers:

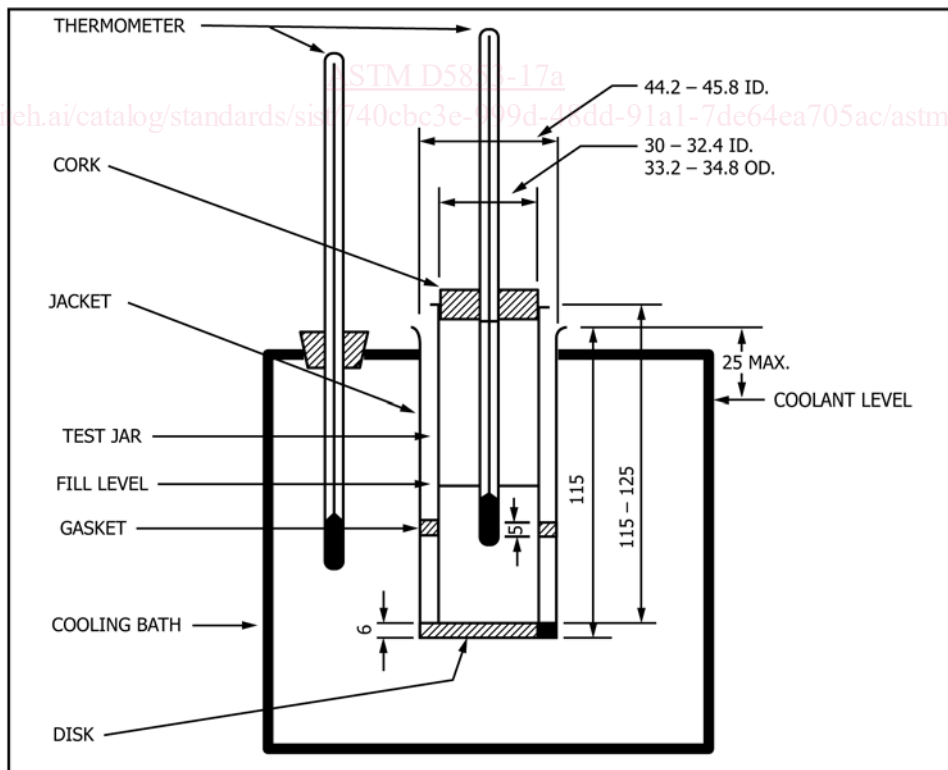

NOTE 1—All dimensions are stated in millimetres. Positioning of temperature sensing devices are shown in the figure.

FIG. 1 Apparatus for Pour Point Test

Thermometer	Temperature Range	Thermometer Number	
		ASTM	IP
High cloud and pour	-38 °C to +50 °C	5C, S5C	1C
Low cloud and pour	-80 °C to +20 °C	6C	2C
Melting point	+32 °C to +127 °C	61C	63C

6.1.2.2 Since separation of liquid column thermometers occasionally occurs and may escape detection, the ice point of the thermometers shall be checked prior to the test and used only if they are accurate within ± 1 °C (see Test Method E77).

6.1.2.3 Digital Contact Thermometer Requirements for Pour Point:³

Parameter	Requirement
DCT	Guide E2877 Class F or better
Nominal temperature range ^A	High Pour: -38 °C to 50 °C Low Pour: -80 °C to 20 °C Melt Point: 32 °C to 127 °C
Display resolution	0.1 °C minimum
Accuracy ^B	± 500 mK (± 0.5 °C)
Sensor type	Platinum resistance thermometer (PRT)
Sensor sheath ^C	4.2 mm OD maximum
Sensor length ^D	Less than 10 mm
Immersion depth ^E	Less than 40 mm per Practice D7962
Sample immersion depth	Tip of sheath between 10 mm and 15 mm below sample meniscus Fig. 1
Measurement drift ^E	Less than 500 mK (0.5 °C) per year
Response time ^F	Less than or equal to 4 s per footnote F
Calibration error	Less than 500 mK (0.5 °C) over the range of intended use
Calibration range	Consistent with temperature range of use
Calibration data	Four data points evenly distributed over the calibration range that is consistent with the range of use. The calibration data is to be included in the calibration report.
Calibration report	From a calibration laboratory with demonstrated competency in temperature calibration which is traceable to a national calibration laboratory or metrology standards body

^A The nominal temperature range may be different from the values shown provided the calibration and accuracy criteria are met.

^B Accuracy is the combined accuracy of the DCT unit, which is the display and sensor.

^C Sensor sheath is the tube that holds the sensing element. The value is the outside diameter of the sheath segment containing the sensor element.

^D The physical length of the temperature sensing element.

^E As determined by Practice D7962 or an equivalent procedure.

^F *Response Time*—The time for a DCT to respond to a step change in temperature. The response time is 63.2 % of the step change time as determined per Section 9 of Test Methods E644. The step change evaluation begins at 20 °C \pm 5 °C air to 77 °C \pm 5 °C with water circulating at 0.9 m/s \pm 0.09 m/s past the sensor.

NOTE 1—When making measurements below -40 °C with a PRT, it

³ Supporting data have been filed at ASTM International Headquarters and may be obtained by requesting Research Report RR:D02-1826. Contact ASTM Customer Service at service@astm.org.

may be necessary to use a 1000 Ω sensor in order to obtain accurate measurements.

NOTE 2—When the DCT display is mounted on the end to the probe's sheath, the test jar with the probe inserted will be unstable. To resolve this, it is recommended that the probe be between 15 cm and 30 cm in length. A 5 cm long stopper that has a low thermal conductivity with approximately half of it inserted in the sample tube will improve stability.

6.1.2.4 The DCT calibration drift shall be checked at least annually by either measuring the ice point or against a reference thermometer in a constant temperature bath at the prescribed immersion depth to ensure compliance with 6.1.2.3. See Practice D7962.

NOTE 3—When a DCT's calibration drifts in one direction over several calibration checks, it is an indication of a change in the DCT, thus a full recalibration is necessary.

6.1.3 *Cork*, to fit the test jar, center bored for the test thermometer.

6.1.4 *Jacket*, watertight, cylindrical, metal, flat bottomed, 115 mm \pm 3 mm depth, with inside diameter of 44.2 mm to 45.8 mm. It shall be supported in a vertical position in the cooling bath (6.1.7) so that no more than 25 mm projects out of the cooling medium. The jacket shall be capable of being cleaned.

6.1.5 *Disk*, cork or felt, 6 mm thick to fit loosely inside the jacket.

6.1.6 *Gasket*, to fit snugly around the outside of the test jar and loosely inside the jacket. The gasket shall be made of rubber, leather, or other material that is sufficiently elastic to cling to the test jar and hard enough to hold its shape. Its purpose is to prevent the test jar from touching the jacket.

6.1.7 *Cooling Bath or Baths*, of a type suitable for obtaining the required temperatures. The size and shape of the bath are optional, but a support to hold the jacket firmly in a vertical position is essential. The bath temperature shall be monitored by means of the appropriate thermometer (6.1.2) or any other temperature measuring device capable of measuring and displaying the designated temperature with the required precision and accuracy. The required bath temperatures shall either be obtained by refrigeration or by suitable cooling mixtures and shall maintain the designated temperatures to within ± 1.5 °C. Cooling mixtures commonly used for bath temperatures are shown in Table 1.

6.2 *Water Bath*—The size and shape of the bath are optional, but a support to hold the test jar immersed in the bath to above the sample height in the test jar and in a firm vertical position is required. The required bath temperature may be maintained by any suitable means, provided the temperature can be monitored and controlled to the designated temperature (± 1 °C (9.1.4; 9.2.4)).

6.3 *Pressure Vessel*, constructed of stainless steel according to the dimensions given in Fig. 2, and capable of withstanding a test pressure of 700 kPa. Alternative designs for the pressure vessel cap and synthetic rubber gasket may be used provided that the internal dimensions of the pressure vessel are the same as those shown in Fig. 2.

NOTE 4—This pressure vessel is identical to the pressure vessel described in Test Method D130.

TABLE 1 Cooling Mixtures and Bath Temperatures

	Bath Temperature
Ice and water	0 °C ± 1.5°C
Crushed ice and sodium chloride crystals or Acetone or petroleum naphtha or methanol or ethanol (see Section 7) with solid carbon dioxide added to give the desired temperature	-18 °C ± 1.5°C
Acetone or petroleum naphtha or methanol or ethanol (see Section 7) with solid carbon dioxide added to give the desired temperature	-33 °C ± 1.5°C
Acetone or petroleum naphtha or methanol or ethanol (see Section 7) with solid carbon dioxide added to give the desired temperature	-51 °C ± 1.5°C
Acetone or petroleum naphtha or methanol or ethanol (see Section 7) with solid carbon dioxide added to give the desired temperature	-69 °C ± 1.5°C

6.4 *Timing Device*, capable of measuring up to 30 s with a resolution of at least 0.1 s and an accuracy of ±0.2 s or better.

7. Reagents and Materials

7.1 The following solvents of technical grade are appropriate for low-temperature bath media.

7.1.1 *Acetone*, (**Warning**—Extremely flammable.)

7.1.2 *Petroleum Naphtha*, (**Warning**—Combustible. Vapor harmful.)

NOTE 5—Typical petroleum naphtha used for cleaning purposes are VM and P naphthas.

7.2 *Toluene*, technical grade (**Warning**—Flammable. Vapor harmful.)

7.3 *Solid Carbon Dioxide*, (**Warning**—Extremely cold (-78.5 °C).)

7.4 *Sodium Chloride Crystals*—Commercial or technical grade sodium chloride is suitable.

7.5 *Ethanol or Ethyl Alcohol*—A commercial or technical grade of dry ethanol is suitable for the cooling bath. (**Warning**—Flammable. Denatured. Cannot be made non-toxic.)

7.6 *Methanol or Methyl Alcohol*—A commercial or technical grade of dry methanol is suitable for the cooling bath. (**Warning**—Flammable. Vapor harmful.)

8. Sampling, Test Samples, and Test Specimens

NOTE 6—Sampling is defined as all steps required to obtain a portion of the contents of any pipe, tank, or other system and to place the sample into the laboratory test container.

8.1 *Laboratory Sample*—It is essential that the sample received by the laboratory is representative of the batch or lot of crude oil from which it was taken. Practices [D4057](#) and [D4177](#) provide guidance for obtaining such representative samples.

8.2 *Preparation of Test Samples*—The pour point of crude oils is very sensitive to trace amounts of high melting waxes. Exercise meticulous care to ensure such waxes, if present, are either completely melted or, if volatility constraints prevent heating to complete melting, homogeneously suspended in the

sample ([Appendix X1](#)). Inspect the walls of the original container to ensure that no high melting point material is left sticking to the wall.

NOTE 7—It is not possible to define universal mandatory rules for the preparation of crude oil test samples. Guidelines for sample handling for the most common situations are given in [Appendix X1](#).

9. Procedure

9.1 *Procedure A for Maximum (Upper) Pour Point:*

9.1.1 Pour the test sample into the test jar to the level mark. If necessary, reheat the test sample to a temperature at least 20 °C above the expected pour point ([8.2](#) and [Appendix X1](#)) but not higher than a temperature of 60 °C (**Warning**—The vapor pressure of crude oils at temperatures higher than 60 °C will usually exceed 100 kPa. Under these circumstances the sample container may rupture. Opening of the container may induce foaming with resultant loss of sample and possible injury to personnel.)

9.1.2 Immediately close the test jar with the cork carrying the high cloud and pour thermometer, or, if the expected pour point is above 36 °C, the melting point thermometer. Adjust the position of the cork and thermometer so the cork fits tightly, the thermometer and the jar are coaxial, and the thermometer bulb is immersed to a depth that places the beginning of the capillary 3 mm below the surface of the test specimen.

9.1.3 Keep the test jar with the test specimen at room temperature (between 18 °C and 24 °C) for at least 24 h.

NOTE 8—The pour point of a crude oil is dependent on the state of crystallization of the wax in the test specimen. In crude oils, achieving equilibrium between crystallized wax and dissolved wax is a rather slow process. However, experience has shown that in a majority of cases, such an equilibrium is reached within 24 h. Especially when a DCT is used, additional care must be taken to ensure that the thermometer does not move in the sample during the test, so additional support elements will likely be needed.

9.1.4 If the expected pour point is greater than 36 °C, heat the sample to 9 °C above the expected pour point. If the expected pour point is less than 36 °C, heat the sample to a temperature of 45 °C ± 1 °C. Maintain the water bath ([6.2](#)) to heat the sample at 48 °C ± 1 °C or at a temperature 12 °C higher than the expected pour point, whichever is higher.

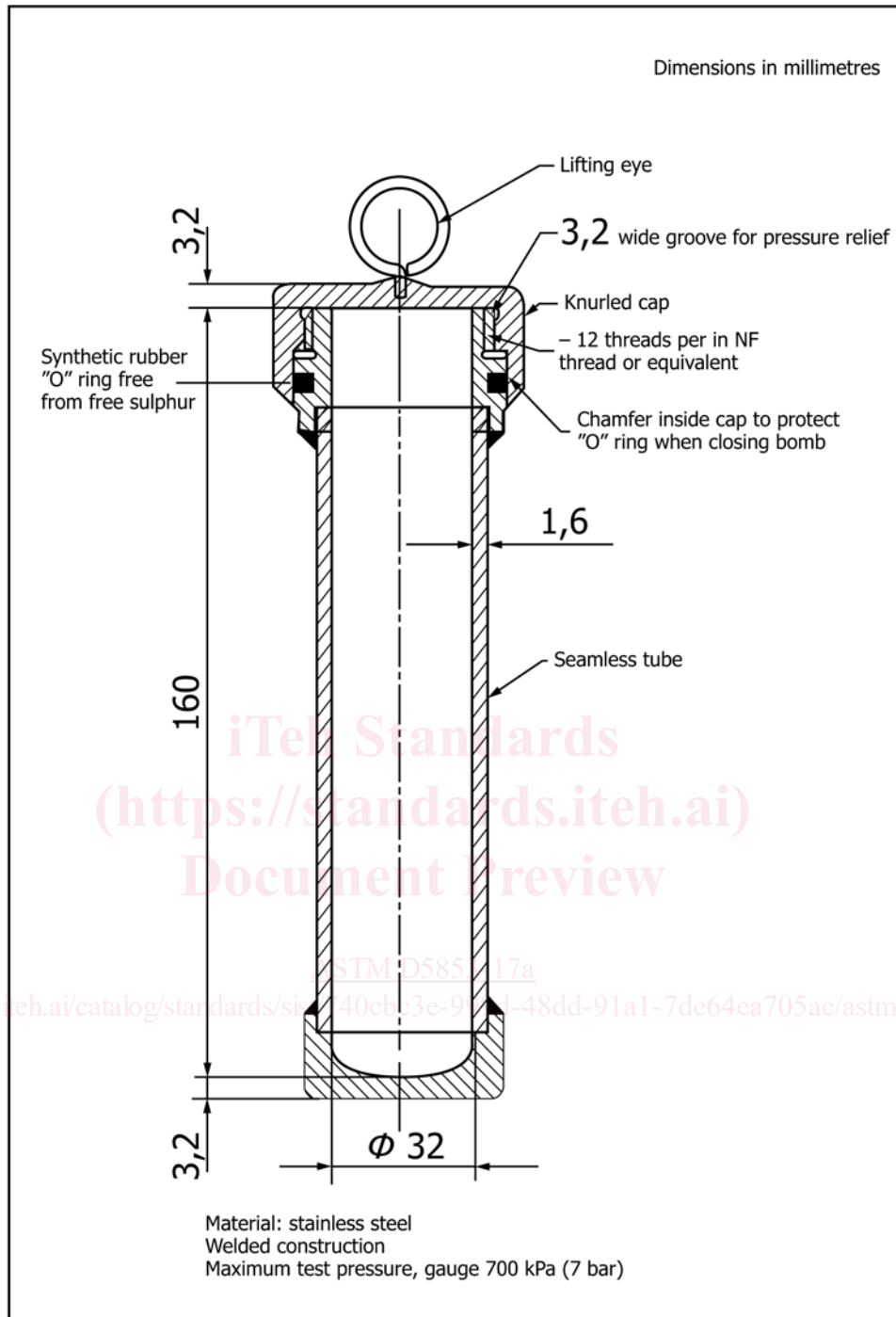

FIG. 2 Pressure Vessel

9.1.4.1 As soon as the test specimen has reached the required temperature, remove the cork carrying the thermometer and stir the test specimen gently with a spatula or similar device. Put the cork carrying the thermometer back in place (see 9.1.2).

9.1.5 Ensure that the disk, gasket, and the inside of the jacket are clean and dry. Place the disk in the bottom of the jacket. Place the disk and jacket in the cooling medium a minimum of 10 min before the test jar is inserted. The use of a jacket cover, while the empty jacket is cooling, is permitted.

Remove the test jar from the water bath and dry with a tissue. Place the gasket around the test jar, 25 mm from the bottom. Insert the test jar into the jacket in the first bath maintained at 21 °C and commence observations for pour point. Never place a test jar directly into the cooling medium.

9.1.6 Exercise care not to disturb the mass of test specimen nor permit the thermometer to shift in the test specimen; any disturbance of the spongy network of wax crystals will lead to a lower pour point and erroneous results (Note 8).

NOTE 9—With dark colored materials, such as crude oils, it is impractical to observe, in the test jar, the onset of crystallization and network formation in the test specimen. Hence, it is presumed that network formation will begin at the very early stages of the cooling sequence.

9.1.7 Pour points are expressed in temperatures which are positive or negative multiples of 3 °C. Begin to examine the appearance of the test specimen when the temperature of the test specimen is 9 °C above the expected pour point (estimated as a multiple of 3 °C). At each test thermometer reading which is a multiple of 3 °C below the starting temperature, remove the test jar from the jacket. When necessary, remove moisture that limits visibility of the test specimen by wiping the surface of the test jar with a clean cloth moistened in alcohol at approximately the temperature of the test specimen in the jar. Then tilt the jar just enough to ascertain whether there is movement of the test specimen in the jar. When movement is observed, immediately return the test jar into the jacket. If movement of the specimen in the test jar is noted, then replace the test jar immediately in the jacket, and repeat a test for flow at the next temperature, 3 °C lower. Typically the complete operation of removal, wiping, and replacement shall require not more than 3 s.

9.1.7.1 If the test specimen has not ceased to flow when its temperature has reached 30 °C, transfer the test jar to the next lower temperature bath per the following schedule:

- (1) If the test specimen is at +30 °C, move to 0 °C bath;
- (2) If the test specimen is at +9 °C, move to -18 °C bath;
- (3) If the test specimen is at -9 °C, move to -33 °C bath;

and

- (4) If the test specimen is at -24 °C, move to -51 °C bath.

9.1.7.2 If the test specimen in the jar does not show movement when tilted, hold the jar in a horizontal position for 5 s, as shown by an accurate timing device (6.4), and observe the specimen carefully. If the test specimen shows any movement before 5 s has passed, replace the test jar immediately in the jacket, and repeat a test for flow at the next temperature, 3 °C lower.

9.1.8 Continue in this manner until a point is reached at which the test specimen shows no movement when the test jar is held in a horizontal position for 5 s. Record the observed reading of the test temperature.

9.1.8.1 If the test specimen has reached -36 °C and still shows movement, discontinue the test.

NOTE 10—To determine compliance with existing specifications having pour point limits at temperatures not divisible by 3 °C, it is acceptable practice to conduct the pour point measurement according to the following schedule. Begin to examine the appearance of the test specimen when the temperature of the test specimen is 9 °C above the specification pour point. Continue observations at 3 °C intervals as described in 9.1.6 and

9.1.7 until the specification temperature is reached. Report the sample as passing or failing the specification limit.

9.2 Procedure B for Minimum (Lower) Pour Point:

9.2.1 Pour 50 g of the test sample into a clean pressure vessel (6.3 and Note 11). When necessary, reheat the test sample to a temperature of at least 20 °C above the expected pour point (8.2 and Appendix X1) but not higher than 60 °C (Warning—The vapor pressure of crude oils at temperatures higher than 60 °C will usually exceed 100 kPa. Under these circumstances the sample container may rupture. Opening of the container may induce foaming with resultant loss of sample and possible injury to personnel.) Check that the rubber ring is in place and screw the lid on tightly.

NOTE 11—The pressure vessel may be cleaned by any appropriate solvent, provided the solvent is capable of dissolving remnants of high melting wax and asphaltenes. Hot toluene (100 °C) has been found to be an appropriate solvent for this purpose.

9.2.2 Heat the pressure vessel in an oil bath or by any other suitable means to a temperature of 105 °C ± 2 °C and leave at that temperature for at least 30 min.

9.2.3 Take the pressure vessel from the oil bath, wipe and dry the surface of the pressure vessel, swirl gently to homogenize the contents, and leave the pressure vessel to cool at room temperature for exactly 20 min ± 30 s.

9.2.4 Carefully open the pressure vessel and transfer the sample into the test jar filling to the level mark of the test jar, preheated in a water bath (6.2) kept at a temperature of 48 °C ± 1 °C (Warning—After 20 min at ambient temperature, the temperature of the test specimen will be approximately 50 °C. The vapor pressure at that temperature may still exceed 100 kPa. Under these circumstances, inattentive opening of the pressure vessel may induce foaming with resultant loss of sample and possible injury to personnel.)

9.2.5 Immediately close the test jar with the cork carrying the high cloud and pour thermometer, or, if the expected pour point is above 36 °C, the melting point thermometer. Adjust the position of the cork and thermometer so the cork fits tightly, the thermometer and the jar are coaxial, and the thermometer bulb is immersed to a depth which places the beginning of the capillary 3 mm below the surface of the test specimen.

9.2.6 Proceed as described in 9.1.5 – 9.1.8.

10. Calculation and Report

10.1 Add 3 °C to the temperature recorded in 9.1.8 and report as Maximum Pour Point, ASTM D5853, Procedure A, or Minimum Pour Point, ASTM D5853, Procedure B, if the procedure in 9.2 has been followed.

10.2 If the test was discontinued (9.1.8.1), report the pour point as ≤ -36 °C.

11. Precision and Bias

11.1 The following criteria are to be used for judging the acceptability of results (95 % confidence):

11.1.1 *Repeatability*—The difference between successive test results obtained by the same operator with the same apparatus under constant operating conditions on identical test