



Designation: **C761 – 11 C761 – 18**

Standard Test Methods for Chemical, Mass Spectrometric, Spectrochemical, Nuclear, and Radiochemical Analysis of Uranium Hexafluoride¹

This standard is issued under the fixed designation C761; the number immediately following the designation indicates the year of original adoption or, in the case of revision, the year of last revision. A number in parentheses indicates the year of last reapproval. A superscript epsilon (ϵ) indicates an editorial change since the last revision or reapproval.

1. Scope

1.1 These test methods cover or give reference to procedures for subsampling and for chemical, mass spectrometric, spectrochemical, nuclear, and radiochemical analysis of uranium hexafluoride (UF_6). Most of these test methods are in routine use to determine conformance to UF_6 specifications in the Enrichment and Conversion Facilities.

1.2 The analytical procedures in this document appear in the following order:

NOTE 1—Subcommittee C26.05 will confer with C26.02 concerning the renumbered section in Test Methods C761 to determine how concerns with renumbering these sections are best addressed in subsequent publications as analytical methods are replaced with stand-alone analytical methods.

	Sections
Subsampling of Uranium Hexafluoride	7
Subsampling of Uranium Hexafluoride	8
Gravimetric Determination of Uranium	8 – 16
Gravimetric Determination of Uranium	9 – 17
Titrimetric Determination of Uranium	17
Titrimetric Determination of Uranium	18
Preparation of High-Purity U_3O_8	18
Preparation of High-Purity U_3O_8	19
Isotopic Analysis	19
Isotopic Analysis	20
Determination of Hydrocarbons, Chlorocarbons, and Partially Substituted Halohydrocarbons	20 – 26
Determination of Hydrocarbons, Chlorocarbons, and Partially Substituted Halohydrocarbons	21 – 27
Determination of Antimony	27
Determination of Antimony	28
Determination of Bromine	28
Determination of Bromine	29
Determination of Chlorine	29 – 35
Determination of Chlorine	30 – 36
Determination of Silicon and Phosphorus	36 – 42
Determination of Silicon and Phosphorus	37 – 43
Determination of Boron and Silicon	43
Determination of Boron and Silicon	44
Determination of Ruthenium	44
Determination of Ruthenium	45
Determination of Titanium and Vanadium	45
Determination of Titanium and Vanadium	46
Spectrographic Determination of Metallic Impurities	46
Spectrographic Determination of Metallic Impurities	47
Determination of Tungsten	47
Determination of Tungsten	48
Determination of Thorium and Rare Earths	48
Determination of Thorium and Rare Earths	49
Determination of Molybdenum	49
Determination of Molybdenum	50
Atomic Absorption Determination of Metallic Impurities	50 – 55
Atomic Absorption Determination of Metallic Impurities	51 – 56
Impurity Determination by Spark-Source Mass Spectrography	56
Impurity Determination by Spark-Source Mass Spectrography	57

¹ These test methods are under the jurisdiction of ASTM Committee C26 on Nuclear Fuel Cycle and are the direct responsibility of Subcommittee C26.05 on Methods of Test.

Current edition approved May 15, 2011; Feb. 1, 2018. Published July 2011; February 2018. Originally approved in 1973. Last previous edition approved in 2004²⁰¹¹ as C761 – 04C761 – 11.^{ε1}; DOI: 10.1520/C0761-11; 10.1520/C0761-18.

Determination of Boron-Equivalent Neutron Cross-Section	57
Determination of Boron-Equivalent Neutron Cross Section	58
Determination of Uranium-233 Abundance by Thermal Ionization Mass Spectrometry	58
Determination of Uranium-233 Abundance by Thermal Ionization Mass Spectrometry	59
Determination of Uranium-232 by Alpha Spectrometry	59—65
Determination of Uranium-232 by Alpha Spectrometry	60—66
Determination of Fission Product Activity	66
Determination of Fission Product Activity	67
Determination of Plutonium by Ion Exchange and Alpha Counting	67—74
Determination of Plutonium by Ion Exchange and Alpha Counting	68—72
Determination of Plutonium by Extraction and Alpha Counting	72—79
Determination of Plutonium by Extraction and Alpha Counting	73—80
Determination of Neptunium by Extraction and Alpha Counting	80—87
Determination of Neptunium by Extraction and Alpha Counting	81—88
Atomic Absorption Determination of Chromium Soluble In Uranium Hexafluoride	88—94
Atomic Absorption Determination of Chromium Soluble In Uranium Hexafluoride	89—95
Atomic Absorption Determination of Chromium Insoluble In Uranium Hexafluoride	95—101
Atomic Absorption Determination of Chromium Insoluble In Uranium Hexafluoride	101—102
Determination of Technetium-99 In Uranium Hexafluoride	102—110
Determination of Technetium-99 In Uranium Hexafluoride	103—110
Method for the Determination of Gamma-Energy Emission Rate from Fission Products in Uranium Hexafluoride	111
Method for the Determination of Gamma-Energy Emission Rate from Fission Products in Uranium Hexafluoride	112
Determination of Metallic Impurities by ICP-AES	112—121
Determination of Metallic Impurities by ICP-AES	113—122
Determination of Molybdenum, Niobium, Tantalum, Titanium, and Tungsten by ICP-AES	122—131
Determination of Molybdenum, Niobium, Tantalum, Titanium, and Tungsten by ICP-AES	123—132

1.3 The values stated in SI units are to be regarded as standard. No other units of measurement are included in this standard.

1.4 *This standard does not purport to address all of the safety concerns, if any, associated with its use. It is the responsibility of the user of this standard to establish appropriate safety, health, and environmental practices and determine the applicability of regulatory limitations prior to use.* (For specific safeguard and safety consideration statements, see Section 67.)

1.5 *This international standard was developed in accordance with internationally recognized principles on standardization established in the Decision on Principles for the Development of International Standards, Guides and Recommendations issued by the World Trade Organization Technical Barriers to Trade (TBT) Committee.*

2. Referenced Documents

2.1 The following documents of the issue in effect on date of material procurement form a part of this specification to the extent referenced herein:

2.2 *ASTM Standards:*²

[C787 Specification for Uranium Hexafluoride for Enrichment](#)

[C799 Test Methods for Chemical, Mass Spectrometric, Spectrochemical, Nuclear, and Radiochemical Analysis of Nuclear-Grade Uranyl Nitrate Solutions](#)

[C859 Terminology Relating to Nuclear Materials](#)

[C996 Specification for Uranium Hexafluoride Enriched to Less Than 5 % ²³⁵U](#)

[C1128 Guide for Preparation of Working Reference Materials for Use in Analysis of Nuclear Fuel Cycle Materials](#)

[C1219 Test Methods for Arsenic in Uranium Hexafluoride \(Withdrawn 2015\)](#)³

[C1233 Practice for Determining Equivalent Boron Contents of Nuclear Materials](#)

[C1267 Test Method for Uranium by Iron \(II\) Reduction in Phosphoric Acid Followed by Chromium \(VI\) Titration in the Presence of Vanadium](#)

[C1287 Test Method for Determination of Impurities in Nuclear Grade Uranium Compounds by Inductively Coupled Plasma Mass Spectrometry](#)

[C1295 Test Method for Gamma Energy Emission from Fission and Decay Products in Uranium Hexafluoride and Uranyl Nitrate Solution](#)

² For referenced ASTM standards, visit the ASTM website, www.astm.org, or contact ASTM Customer Service at service@astm.org. For *Annual Book of ASTM Standards* volume information, refer to the standard's Document Summary page on the ASTM website.

³ The last approved version of this historical standard is referenced on www.astm.org.

- C1344 Test Method for Isotopic Analysis of Uranium Hexafluoride by Single-Standard Gas Source Mass Spectrometer Method
- C1346 Practice for Dissolution of UF₆ from P-10 Tubes
- C1380 Test Method for the Determination of Uranium Content and Isotopic Composition by Isotope Dilution Mass Spectrometry
- C1413 Test Method for Isotopic Analysis of Hydrolyzed Uranium Hexafluoride and Uranyl Nitrate Solutions by Thermal Ionization Mass Spectrometry
- C1428 Test Method for Isotopic Analysis of Uranium Hexafluoride by Single-Standard Gas Source Multiple Collector Mass Spectrometer Method
- C1429 Test Method for Isotopic Analysis of Uranium Hexafluoride by Double-Standard Multi-Collector Gas Mass Spectrometer
- C1441 Test Method for The Analysis of Refrigerant 114, Plus Other Carbon-Containing and Fluorine-Containing Compounds in Uranium Hexafluoride via Fourier-Transform Infrared (FTIR) Spectroscopy
- C1474 Test Method for Analysis of Isotopic Composition of Uranium in Nuclear-Grade Fuel Material by Quadrupole Inductively Coupled Plasma-Mass Spectrometry
- C1477 Test Method for Isotopic Abundance Analysis of Uranium Hexafluoride and Uranyl Nitrate Solutions by Multi-Collector, Inductively Coupled Plasma-Mass Spectrometry
- C1508 Test Method for Determination of Bromine and Chlorine in UF₆ and Uranyl Nitrate by X-Ray Fluorescence (XRF) Spectroscopy
- C1539 Test Method for Determination of Technetium-99 in Uranium Hexafluoride by Liquid Scintillation Counting
- C1561 Guide for Determination of Plutonium and Neptunium in Uranium Hexafluoride and U-Rich Matrix by Alpha Spectrometry
- C1636 Guide for the Determination of Uranium-232 in Uranium Hexafluoride
- C1689 Practice for Subsampling of Uranium Hexafluoride
- C1742 Test Method for Isotopic Analysis of Uranium Hexafluoride by Double Standard Single-Collector Gas Mass Spectrometer Method
- D1193 Specification for Reagent Water
- D3084 Practice for Alpha-Particle Spectrometry of Water
- E60 Practice for Analysis of Metals, Ores, and Related Materials by Spectrophotometry
- 2.3 *American Chemical Society Specification:*
*Reagent Chemicals*⁴
- 2.4 *Other Specifications:*
Uranium Hexafluoride**Hexafluoride:** ±Base Charges, Use Charges, Special Charges, Table of Enriching Services, Specifications, and Packaging⁵
- USEC 651** Good Handling and Practices for UF₆
- 2.5 *ANSI Standards:*⁶
- ANSI N 14.1** Nuclear Material-Uranium Hexafluoride-Packaging for Transport
- 2.6 *ISO Standards:*
ISO 7195 Nuclear Energy-Packaging of Uranium Hexafluoride (UF₆) for Transport

3. Terminology

3.1 Definitions:

3.1.1 For definitions of terms relating to the nuclear fuel cycle, refer to Terminology **C859**.

4. Significance and Use

4.1 Uranium hexafluoride is a basic material used to prepare nuclear reactor fuel. To be suitable for this purpose the material must meet criteria for uranium content, isotopic composition, metallic impurities, hydrocarbon and halohydrocarbon content. These test methods are designed to determine whether the material meets the requirements described in Specifications **C787** and **C996**.

5. Reagents

5.1 *Purity of Reagents*—Reagent grade chemicals shall be used in all procedures. Unless otherwise indicated, all reagents shall conform to the specifications of the Committee on Analytical Reagents of the American Chemical Society, where such specifications are available.⁴ Other grades may be used, provided that it is first established that the reagent to be used is of sufficiently high purity to permit its use without lessening the accuracy of the determination.

⁴ *Reagent Chemicals, American Chemical Society Specifications*, American Chemical Society, Washington, DC. For suggestions on the testing of reagents not listed by the American Chemical Society, see *Analar Standards for Laboratory Chemicals*, BDH Ltd., Poole, Dorset, U.K. and the *United States Pharmacopeia and National Formulary*, U.S. Pharmacopeial Convention, Inc. (USPC), Rockville, MD.

⁵ United States Department of Energy, Oak Ridge, TN 37830.

⁶ Available from American National Standards Institute (ANSI), 25 W. 43rd St., 4th Floor, New York, NY 10036.

5.2 *Purity of Water*—Unless otherwise indicated, references to water shall mean reagent water conforming to Specification **D1193**.⁷

6. Rejection

6.1 Rejection or acceptance criteria are described in Specifications **C787** and **C996**.

7. Safety Considerations

7.1 Since UF₆ is radioactive, toxic, and highly reactive, especially with reducing substances and moisture (see Uranium Hexafluoride: Handling Procedures and Container Criteria, sections **2.42.4** through **2.62.6**), appropriate facilities and practices for sampling and analysis must be provided.

7.2 Hydrofluoric acid is a highly corrosive acid that can severely burn skin, eyes, and mucous membranes. Hydrofluoric acid is similar to other acids in that the initial extent of the burn depends on the concentration, the temperature, and the duration of the contact with the acid. Hydrofluoric acid differs from other acids because the fluoride ion readily penetrates the skin, causing destruction of deep tissue layers. Unlike other acids that are rapidly neutralized, hydrofluoric acid reactions with tissue may continue for days if left untreated. Due to the serious consequences of hydrofluoric acid burns, prevention of exposure or injury of personnel is the primary goal. Utilization of appropriate laboratory controls (hoods) and wearing adequate personal protective equipment to protect from skin and eye contact Familiarization and compliance with the Safety Data Sheet is essential.

7.3 *Committee E-26C26 Safeguards Statement:*

7.3.1 The material (uranium hexafluoride) to which these test methods apply, is subject to nuclear safeguards regulations governing its possession and use. The following analytical procedures in these test methods have been designated as technically acceptable for generating safeguards accountability measurement data: Gravimetric Determination of Uranium; Titrimetric Determination of Uranium; All Isotopic Analyses.

7.3.2 When used in conjunction with appropriate certified Reference Materials (CRMs), these procedures can demonstrate traceability to the national measurement base. However, adherence to these procedures does not automatically guarantee regulatory acceptance of the resulting safeguards measurements. It remains the sole responsibility of the user of these test methods to assure that its application to safeguards has the approval of the proper regulatory authorities.

SUBSAMPLING OF URANIUM HEXAFLUORIDE

7. Scope

~~7.1 This test method has been discontinued (see C 761 – 04^{E1}). The subsampling of UF₆ from bulk sample containers into smaller containers suitable for laboratory analyses has been published as a separate Practice, **C1689**.~~

8. Scope <https://standards.iteh.ai/catalog/standards/sist/2cdade79-e9cb-48b0-8d81-adbc093fb023/astm-c761-18>

8.1 This test method has been discontinued (see C 761 – 04^{E1}). The subsampling of UF₆ from bulk sample containers into smaller containers suitable for laboratory analyses has been published as a separate Practice **C1689**.

GRAVIMETRIC DETERMINATION OF URANIUM

9. Scope

9.1 Practice **C1346** is applicable to the hydrolysis of uranium hexafluoride in polychlorotrifluoroethylene (P10) tubes. The following test method is then applicable to the direct gravimetric determination of uranium.

10. Summary of Test Method

10.1 A sample of uranium hexafluoride is weighed, cooled in liquid nitrogen, and hydrolyzed with water. The uranyl fluoride solution produced is evaporated to dryness and converted to uranic oxide by pyrohydrolysis. The uranium content is determined from the weight of the uranium oxide after correcting for stoichiometry based on isotopic content, ignition conditions, and nonvolatile impurities. Ref. **(1-4)**.⁸

11. Interferences

11.1 Nonvolatile impurities affect the accuracy of the method and must be measured by spectrographic analysis with corrections applied.

⁷ Type 1 and 2 water have been found to be suitable.

⁸ The boldface numbers in parentheses refer to a list of references at the end of these test methods.

12. Apparatus

- 12.1 Polytrifluorochloroethylene (PTFCE) Sample Tube, TFCE Gasket, Flare Nut, and Plug, see Fig. 1.
- 12.2 Platinum Boat and Cover—The cover should be platinum gauze (52 mesh) and shaped to cover the boat (Fig. 2).
- 12.3 Muffle Furnace, must be capable of operating continuously at 875°C and maintain this temperature within ±25°C. The furnace shall be equipped with a steam supply that is passed through a tube furnace to preheat the steam to 875°C.
- 12.4 Tube Furnace, must be capable of operating continuously at 875°C and maintain this temperature within 25°C.
- 12.5 Infrared Heat Lamps, 250 watts.
- 12.6 Analytical Balance.
- 12.7 Vacuum Oven.
- 12.8 Dewar Flask, stainless steel.
- 12.9 Spatula, platinum.
- 12.10 PTFCE Rod, 120 mm long and 1.6 mm in diameter.
- 12.11 Forceps, platinum tipped.
- 12.12 Jig, suitable for holding the TFCE sample tube so that it can be opened with a wrench.
- 12.13 Box Wrench, to fit sample tube plug.
- 12.14 Beaker, stainless steel, 125 mL capacity.

13. Reagents

- 13.1 Liquid Nitrogen.
- 13.2 Nitric Acid (sp gr 1.42)—concentrated nitric acid (HNO₃).
- 13.3 Nitric Acid (4M)—Mix 500 mL of concentrated HNO₃ with 1500 mL of distilled water.
- 13.4 Detergent.

14. Sampling

- 14.1 A UF₆ sample is taken as described in Practice C1689.

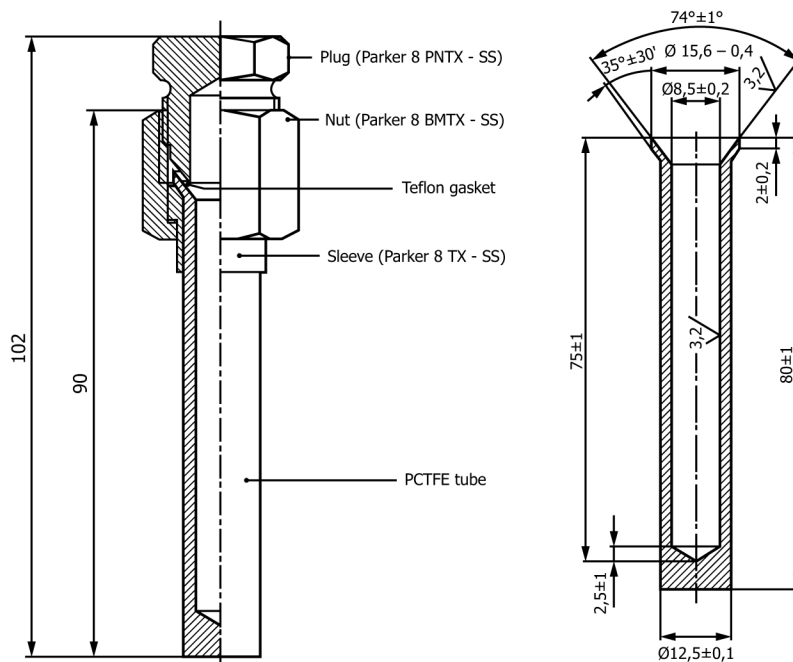
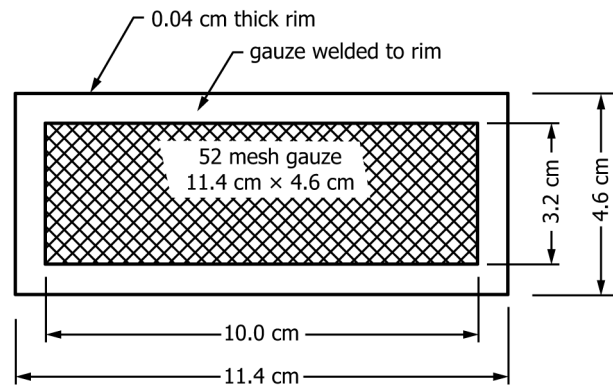
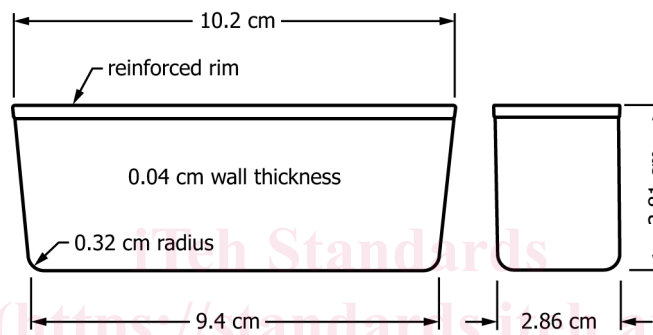

FIG. 1 Example of a Polychlorotrifluoroethylene P-10 Tube



Cover



Boat

FIG. 2 Platinum Boat and Cover

ASTM C761-18

15. Procedure

15.1 Inspect the PTFCE sample tube for leaks.

NOTE 2—An indication of a leak is a yellow-green residue on the flare nut and cap or a yellow discoloration in the tube. Discard the sample if a leak is indicated.

15.2 Allow the sample tube to stand overnight in the laboratory.

15.3 Wipe the sample tube with a lint-free tissue to remove any moisture or foreign material that might be adhering.

15.4 Weigh the sample tube to the nearest 0.1 mg.

15.5 Heat the platinum boat and screen in the pyrohydrolysis furnace at 875°C for 20 min.

15.6 Cool the platinum boat and store in a desiccator for 40 min. Weigh the boat and screen to the nearest 0.1 mg.

15.7 Freeze the sample by immersing the sample tube in liquid nitrogen for 10 min.

15.8 Add enough chilled water to the tared platinum boat to immerse the sample tube (about 50 mL).

15.9 Place the sample tube in the jig and loosen the plug with the box wrench.

15.10 Remove the sample tube from the jig and unscrew the plug while holding the sample tube in an upright position.

15.11 Remove the flare nut from the sample tube and immerse the tube and gasket in the chilled water in the tared platinum boat.

15.12 Let the gasket remain in the chilled water about 30 min.

15.13 Remove the gasket with the forceps and rinse well with deionized water into the boat.

15.14 Place the plug-nut assembly and gasket into a stainless steel beaker for drying.

15.15 Allow the tube to remain in the water until the UF_6 has been hydrolyzed (2 to 4 h).

15.16 Remove the tube from the sample solution by inserting the TFCE rod or platinum spatula into the tube and lifting directly above the boat.

15.17 Rinse the sample tube with deionized water into the boat using extreme care to prevent splashing.

15.18 Cover the sample boat containing the UO_2F_2 solution with the matching cover shown in Fig. 2. Place under the infrared head lamps and evaporate to dryness for 16 h.

15.19 Shake the excess water from the sample tube and place in the stainless beaker containing the plug-nut assembly and gasket.

15.20 Dry the sample tube parts in the vacuum oven at 80°C .

15.21 Allow the unassembled parts to sit in the room overnight.

15.22 Assemble the empty sample tube and weigh to the nearest 0.1 mg.

15.23 Disassemble the sample tube and soak the tube and gasket in 4M HNO_3 at 75° to 80°C for 1 h.

15.24 Rinse with deionized water and place in the stainless steel beaker.

15.25 Clean the metal parts with detergent and rinse with deionized water and acetone.

15.26 Place the metal parts to the stainless steel beaker and dry all parts in the vacuum oven at 80°C overnight.

15.27 Reassemble the sample tube for the next sample.

15.28 Set the temperatures of the furnace and tube furnace at 875°C .

15.29 Establish a steam flow to the furnace equal to 1 L of water per hour.

15.30 Place the boat into the furnace with the platinum cover on the boat and pyrohydrolyze the sample for 1 h.

15.31 Remove the boat from the furnace, cool, and place in a desiccator while still warm.

15.32 Desiccate the sample for 1 h and weigh quickly to the nearest 0.1 mg.

15.33 Transfer a portion of the U_3O_8 residue to a vial and submit for spectrographic analysis to determine the weight of nonvolatile impurities.

15.34 Place the platinum boat in hot 4M HNO_3 for 3 to 4 h and rinse with deionized water acetone.

16. Calculation

16.1 Calculate the weight fraction of uranium in the sample as follows:

$$\text{gU/g UF}_6 = (A - (AB))(\text{Gravimetric Factor})/W \quad (1)$$

where: <https://standards.iteh.ai/catalog/standards/sist/2cdade79-e9cb-48b0-8d81-adbc093fb023/astm-c761-18>

Gravimetric Factor = $\text{gU/g U}_3\text{O}_8$ which varies with isotopic composition. Theoretical stoichiometry for U_3O_8 cannot be assumed and the actual $\text{gU/g U}_3\text{O}_8$ must be established by potentiometric titration (1-4). (Tri-diffusion plant committee with DOE approval has established 0.8479 $\text{g U/g U}_3\text{O}_8$ by titration as the factor for natural uranium,

Gravimetric Factor = $\text{gU/g U}_3\text{O}_8$ which varies with isotopic composition. Theoretical stoichiometry for U_3O_8 cannot be assumed and the actual $\text{gU/g U}_3\text{O}_8$ must be established by potentiometric titration (1-4). (Tri-diffusion plant committee with DOE approval has established 0.8479 $\text{gU/g U}_3\text{O}_8$ by titration as the factor for natural uranium,

A = grams of U_3O_8 from the pyrohydrolysis of UO_2F_2 ,

B = grams of impurity metal oxides per gram of U_3O_8 ,

W = corrected sample weight in grams.

The correction is for the combined effects of cover gas trapped over the UF_6 in the sample tube and the air buoyancy correction (5). The following equation has been determined for the sample tube in Fig. 1 and the subsampling conditions described in Practice C1689. The correction equation is applicable for sample weights in the range of 7 to 13 g.

$$W = (1.00047)x - 0.0058 \quad (2)$$

where:

x = observed UF_6 sample weight, g.

17. Precision and Bias

17.1 *Precision*—The precision within a laboratory and between laboratories was established by analyzing 15 samples at each laboratory. The sampling scheme is shown in Table 1. Within a laboratory, based on 15 measurements made on separate days the relative standard deviation is 0.021 %. The results from all the laboratories are shown in Table 2.

TABLE 1 Interlaboratory Study^A—Determination of Uranium in Uranium Hexafluoride

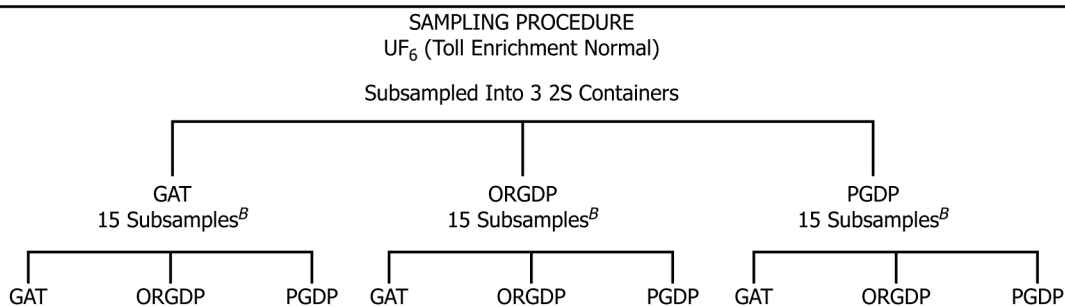

^ADate of study—October 1983; Participating laboratories—Goodyear Atomic Corporation, Portsmouth, Ohio (GAT); Martin Marietta Energy Systems, Inc., Oak Ridge, Tennessee (ORGDP); Martin Marietta Energy Systems, Inc., Paducah, Kentucky (PGDP).
^BFive tubes analyzed at each laboratory.

TABLE 2 Results of Interlaboratory Study—U in UF₆

Analysis Site %U in UF ₆		
GAT	ORGDP	PGDP
<i>Subsampled at GAT:</i>		
67.600	67.619	67.589
67.601	67.574	67.575
67.583	67.607	67.612
67.611	67.600	67.612
67.618	67.606	Sample Lost
<i>Subsampled at ORGDP:</i>		
67.614	67.580	67.611
67.611	67.621	67.598
67.587	67.600	67.501
67.599	67.606	67.610
67.617	67.596	67.624
<i>Subsampled at PGDP:</i>		
67.616	67.588	67.591
67.586	67.602	67.620
67.573	67.612	67.612
67.614	67.606	67.612
67.607		67.586
<i>Mean and Standard Deviation:</i>		
67.602 ± 0.014	67.601 ± 0.013	67.603 ± 0.014

17.2 *Bias*—To establish an estimate of bias for the gravimetric method, a series of comparative analyses of UF₆ control batches were made using the gravimetric and potentiometric titration methods. The potentiometric titration was used as the reference method because the uranium was measured directly using NIST potassium dichromate.⁹ The results are shown in Table 3.

TABLE 3 Determination of Uranium in Uranium Hexafluoride—Comparison of Gravimetric and Potentiometric Titration Methods

Control UF ₆ Date ^A	Method	Number of Measurements	%Uranium		Bias Estimate ^B
			Mean	SD	
9/78	Gravimetric	24	67.610	0.009	-0.001
	Potentiometric Titration	9	67.611	0.015	
5/82–8/82	Gravimetric	30	67.596	0.010	-0.009
	Potentiometric Titration	8	67.605	0.011	
7/83–9/83	Gravimetric	25	67.610	0.006	+0.005
	Potentiometric Titration	8	67.605	0.010	

^A Control UF₆ used in 9/78 was a different batch of material from that used in 1982 and 1983.

^B Potentiometric titration results are used as the reference values for the bias estimates.

⁹ Standard reference material, now available as NIST SRM 136e.

TITRIMETRIC DETERMINATION OF URANIUM

17. Scope

17.1 A sample of the U_3O_8 produced by the hydrolysis of the UF_6 and ignition of the resulting UO_2F_2 is analyzed according to Test Method [C1267](#).

18. Scope

18.1 A sample of the U_3O_8 produced by the hydrolysis of the UF_6 and ignition of the resulting UO_2F_2 is analyzed according to Test Method [C1267](#).

PREPARATION OF HIGH-PURITY U_3O_8

18. Scope

18.1 High purity U_3O_8 can be prepared according to Preparation [C1128](#). High purity uranium is needed for a blank matrix for analyses using ICP-MS, ICP-AES, AA, XRF, and MS equipment.

19. Scope

19.1 High purity U_3O_8 can be prepared according to Preparation [C1128](#). High purity uranium is needed for a blank matrix for analyses using ICP-MS, ICP-AES, AA, XRF, and MS equipment.

ISOTOPIC ANALYSIS

19. Scope

19.1 The isotopic composition can be determined on either gaseous UF_6 or on hydrolyzed UF_6 .

19.2 For gaseous UF_6 , using single collector mass spectrometer instruments, Test Methods [C1344](#) and [C1742](#) have been developed and can be used for single or double standard method respectively. For multi-collector instruments, Test Methods [C1428](#) and [C1429](#), using single or double standard can be used.

19.3 For hydrolyzed UF_6 , methods using Thermal Ionization Mass Spectrometry (TIMS) have been developed and can be used: Test Methods [C1413](#) and [C1380](#). Methods using ICP-MS can also be used: Test Methods [C1474](#) and [C1477](#).

20. Scope

20.1 The isotopic composition can be determined on either gaseous UF_6 or on hydrolyzed UF_6 .

20.2 For gaseous UF_6 , using single collector mass spectrometer instruments, Test Methods [C1344](#) and [C1742](#) have been developed and can be used for single or double standard method respectively. For multi-collector instruments, Test Methods [C1428](#) and [C1429](#), using single or double standard can be used.

20.3 For hydrolyzed UF_6 , methods using Thermal Ionization Mass Spectrometry (TIMS) have been developed and can be used: Test Methods [C1413](#) and [C1380](#). Methods using ICP-MS can also be used: Test Methods [C1474](#) and [C1477](#).

DETERMINATION OF HYDROCARBONS, CHLOROCARBONS, AND HALOHYDROCARBONS

20. Scope

20.1 The determination of some forms of hydrocarbons, chlorocarbons, and halo hydrocarbons in UF_6 vapor can be performed using Test Method [C1441](#). As an alternative, a mass spectrometry technique may be used and is detailed below. Although this test method is only semiquantitative, it is adequate for certifying that the subject impurities do not exceed 0.01 mol % of the UF_6 .

21. Scope

21.1 The determination of some forms of hydrocarbons, chlorocarbons, and halo hydrocarbons in UF_6 vapor can be performed using Test Method [C1441](#). As an alternative, a mass spectrometry technique may be used and is detailed below. Although this test method is only semiquantitative, it is adequate for certifying that the subject impurities do not exceed 0.01 mol % of the UF_6 .

22. Summary of Test Method

22.1 UF_6 is admitted to a mass spectrometer through a gas sample leak, and magnetic scanning is employed to record a spectrum of peaks. A representative group of recorded peaks is compared to the same peaks in a pure UF_6 standard scan to determine whether appreciable ion fragments from subject impurities are present.

23. Interferences

23.1 If detectable impurities are present, a complete mass scan of the range from 12 to 400 is performed. All impurities are then identified from their cracking patterns, and calculations are performed using ionization efficiency factors for the compounds present. Since cracking patterns vary with ionization potential and ionization efficiencies vary with focus conditions, this measurement can only be performed by one proficient in analytical mass spectrometry.

24. Apparatus

24.1 A mass spectrometer with resolution adequate to distinguish between adjacent peaks at $m/e = 400$ is required. For example, a 152-mm radius, 60-deg, Nier-type spectrometer modified for spectrum recording (6) is suitable. The sample inlet system should be of nickel or Monel, equipped with an adjustable viscous-flow or molecular leak for delivering the sample to the ion source.

24.2 The ion source must be fabricated from nonmagnetic material such as Nichrome V, and must be designed so it can be disassembled for cleaning. The magnetic field of the analyzer magnet must be continuously variable from about 200 to 6500 gauss. A single ion collector electrode is suitable, and a vibrating-reed electrometer and 304-mm strip chart recorder are optimum for amplifying and recording ion signals.

24.3 It is quite possible that quadrupole or time-of-flight instruments could be adapted to this measurement.

25. Procedure

25.1 UF_6 Standard Measurements:

25.1.1 Select a standard material that has been given repetitive flash purifications to rid it of all volatile impurities. Isotopic UF_6 standards usually fall in this category.

25.1.2 With the electrometer sensitivity set at $1/100$ of the most sensitive usable operating range, adjust the gas flow to the ion source to record a mass (Note 3) 333 peak (UF_5^+) approximately 80 % of full scale (80 divisions).

NOTE 3—The term “mass” in this procedure alludes to m/e , the mass-to-charge ratio (see also Terminology C859).

25.1.3 Measure the ratio of mass 333 (UF_5^+) to 147.5 (UF_3^{++}). Mass 333 is measured on a sensitivity range one-hundredth that of mass 147.5. Depending on focus conditions, a ratio of the order of 10^2 is obtained. Measure this ratio only once per day and use for calculating results of all samples analyzed that day.

25.1.4 With the electrometer sensitivity set at $1/100$ of the most sensitive usable operating range, increase the gas flow to provide an output signal of approximately 80 divisions at the 147.5 mass position. This gives a detection limit of the order of 2 ppm per chart division: 50 to 100 due to ratio between UF_5^+ and UF_3^{++} , 100 due to sensitivity shunts, and approximately 80 on the recorder chart.

25.1.5 Record a scan of mass range from 12 to 150 using the most sensitive usable operating shunt, and use this scan as a background for all samples analyzed that day.

25.2 UF_6 Sample Measurement:

25.2.1 Introduce the sample to the spectrometer source such that an output intensity of approximately 80 chart divisions is obtained at the 147.5 mass number (UF_3^{++}), using $1/100$ the most sensitive usable operating range.

25.2.2 Record a scan of mass range from 12 to 150 using the most sensitive usable operating range.

25.2.3 Repeat [24.2.1](#) and [24.2.2](#) for each sample to be analyzed that day.

26. Calculation

26.1 Due to mass spectrometer cracking patterns, low-mass ion fragments are produced from all compounds, even the high-mass ones.

26.2 It is practical to look for a representative group of such ion fragments at specific masses. Thus, initially monitor the following masses for purposes of this procedure:

Mass Number	Positively Charged Ion Fragment
15	CH_3
26	C_2H_2
27	C_2H_3
31	CF
43	C_3H_7
47	CCl^{35}
49	CCl^{37}
69	CF_3

26.3 Read sample intensities for the representative ion fragments from the recorder chart.

26.4 Subtract the background intensities observed on the pure standard from respective sample intensities.

26.5 Examine the net intensity at each of the eight mass numbers. (It will be recalled that one recorder chart division of net intensity is equivalent to about 2 ppm on a UF₆ basis; however, ionization efficiencies of compounds differ, and a specific ion fragment may result from many different compounds. Thus, the net intensity at a specific mass number is only qualitative and not a quantitative measurement of impurity.)

26.5.1 If the net ion intensity does not exceed 2 ppm at any of the mass positions, report the sample as containing less than 0.01 mol % of the subject impurities.

26.5.2 Where detectable impurities are apparent, perform a complete mass scan of the range from 12 to 400, identify impurities, and perform calculations using ionization efficiency factors for the compounds present.

27. Reliability

27.1 This simplified procedure was designed specifically to certify that a UF₆ sample contains less than 0.01 mol % hydrocarbons, chlorocarbons, and partially substituted halohydrocarbons. Thus, the procedure is qualitative rather than quantitative in cases where the impurity level is below 100 ppm.

27.2 The detectability limit for any ion fragment is about 2 ppm. The detectability limit for the parent compound could be greater or less than 2 ppm depending on ionization efficiency and cracking pattern. If one of the subject compounds were present to 10 ppm or more, it would be evident from monitoring the eight masses. Thus, a quoted result of less than 0.01 mol % is conservative.

27.3 The results are considered quantitative when the impurity being determined is present to a level greater than 100 ppm. In such instances the impurity is identified and measured. The 95 % symmetrical confidence interval for such a measurement is ±50 % of the quoted impurity.

DETERMINATION OF ANTIMONY

27. Scope

27.1 The Atomic Absorption test method has been discontinued (see C761–96). Antimony can be determined by ICP-MS. Test Method **C1287** can be used.

28. Scope

28.1 The Atomic Absorption test method has been discontinued (see C761–96). Antimony can be determined by ICP-MS. Test Method **C1287** can be used.

DETERMINATION OF BROMINE

28. Scope

28.1 The Spectrophotometric test method has been discontinued (see C761–96). Bromine can be determined by X-Ray spectroscopy. Test Method **C1508** can be used.

29. Scope

29.1 The Spectrophotometric test method has been discontinued (see C761–96). Bromine can be determined by X-Ray spectroscopy. Test Method **C1508** can be used.

DETERMINATION OF CHLORINE

29. Scope

29.1 Chlorine can be determined by X-Ray Spectroscopy. Test Method **C1508** can be used. Chlorine can also be determined by titrimetry. This test method is described below. It is applicable over a range from 10 to 100 ppm chlorine; however, higher concentrations can be measured by appropriate sample dilution.

30. Scope

30.1 Chlorine can be determined by X-Ray Spectroscopy. Test Method **C1508** can be used. Chlorine can also be determined by titrimetry. This test method is described below. It is applicable over a range from 10 to 100 ppm chlorine; however, higher concentrations can be measured by appropriate sample dilution.

31. Summary of Test Method

31.1 The test method consists of treating a hydrolyzed sample of UF₆ with ferrous sulfate in sulfuric acid solution to reduce chlorates, and then with potassium permanganate to liberate free chlorine. The chlorine gas is carried by a nitrogen stream into a potassium iodide solution, and the liberated iodine is titrated with sodium thiosulfate. Bromine, if present, is determined separately, and a correction is applied to the chlorine result.

31.2 It is recommended that the potassium iodide-sodium acetate solution be made up fresh once each week. Any color change signals the need for a new solution. As the solution ages, the blank result increases; therefore, the same potassium iodide solution is used for both sample and blank.

31.3 If the sample solution is allowed to boil too vigorously when chlorine gas is being released, liquid droplets may be carried by the nitrogen stream into the potassium iodide solution, resulting in sample bias.

32. Apparatus

32.1 *Distillation Apparatus*, shown in Fig. 3.

33. Reagents

33.1 *Boric Acid* (H_3BO_3), reagent grade, crystal or powder.

33.2 *Ferrous Sulfate Solution*—5 g $FeSO_4 \times 7H_2O$ dissolved in 500 mL of 3.6 M sulfuric acid.

33.3 *Potassium Iodide* (KI), reagent grade.

33.4 *Potassium Iodide-Sodium Acetate Solution*—Dissolve 100 g of KI and 100 g of $NaC_2H_3O_2 \times 3H_2O$ in distilled water and dilute to 2 L.

33.5 *Potassium Permanganate Solution (1 %)*—Prepare a 1 % solution of $KMnO_4$ in water.

33.6 *Sodium Acetate* ($NaC_2H_3O_2$), reagent grade.

33.7 *Sodium Thiosulfate Solution (0.025 N)*—Prepare a 0.025 N solution of $Na_2S_2O_3$ in water.

33.8 *Starch Indicator Solution*, pH 7.

33.9 *Sulfuric Acid (sp gr 1.84)*—Concentrated sulfuric acid (H_2SO_4).

34. Procedure

34.1 *Sample Preparation:*

34.1.1 Hydrolyze the sample of UF_6 with distilled water. Approximately 250 g of UF_6 from a nickel knockout container may be hydrolyzed to provide a sample for various chemical measurements, or about 20 g from two polychlorotrifluoroethylene sample tubes may be hydrolyzed to provide the chlorine sample. The procedure for hydrolyzing the contents of the polychlorotrifluoroethylene tubes is described here.

34.1.1.1 Immerse the tubes in liquid nitrogen and cool for 10 min.

34.1.1.2 Remove the top flare plugs and collars, and place the tubes into a platinum dish or a polychlorotrifluoroethylene beaker containing 100 mL of chilled distilled water.

34.1.1.3 After hydrolysis of the UF_6 , remove the polychlorotrifluoroethylene tubes and rinse with distilled water. Add the rinse solution to the UO_2F_2 solution.

34.2 *Analysis:*

34.2.1 Fill the graduated cylinder in Fig. 2 to the 150-mL level with KI- $NaC_2H_3O_2$ solution. Then connect the delivery tube so its tip is near the bottom of the solution in the receiving graduate.

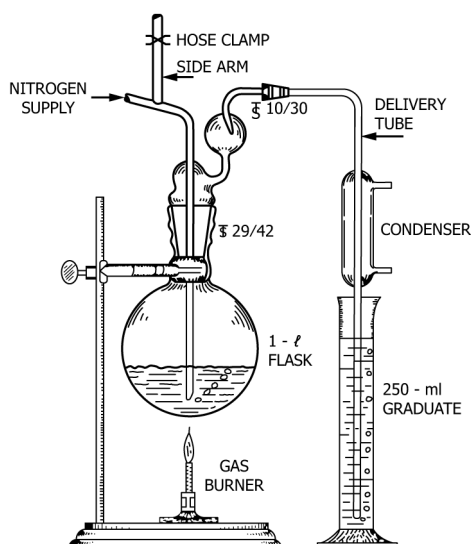

FIG. 3 Apparatus for Distillation of Chlorine