



Designation: D5514/D5514M – 18

## Standard Test Method for Large-Scale Hydrostatic Puncture Testing of Geosynthetics<sup>1</sup>

This standard is issued under the fixed designation D5514/D5514M; the number immediately following the designation indicates the year of original adoption or, in the case of revision, the year of last revision. A number in parentheses indicates the year of last reapproval. A superscript epsilon ( $\epsilon$ ) indicates an editorial change since the last revision or reapproval.

### 1. Scope

1.1 This test method evaluates the stress/time properties of geosynthetics by using hydrostatic pressure to compress the geosynthetic over synthetic or natural test bases consisting of manufactured test pyramids/cones, rocks, soil, or voids.

1.2 This test method allows the user to determine the relative failure mode or points of failure for geosynthetics, or both.

1.3 This test method offers two distinct procedures:

1.3.1 Procedure A incorporates manufactured test pyramids or cones as the base of the testing apparatus. Procedure A is intended to create comparable data between laboratories, and can be used as a guide for routine acceptance tests for various materials.

1.3.2 Procedures B and C incorporate site-specific soil or other material selected by the user as the test base of the testing apparatus. Procedures B and C are methods for geosynthetic design for a specific site.

1.4 The values stated in either SI units or inch-pound units are to be regarded separately as standard. The values stated in each system may not be exact equivalents; therefore, each system shall be used independently of the other. Combining values from the two systems may result in non-conformance with the standard.

1.5 *This standard does not purport to address all of the safety concerns, if any, associated with its use. It is the responsibility of the user of this standard to establish appropriate safety, health, and environmental practices and determine the applicability of regulatory limitations prior to use.* For a specific warning statement, see Section 6.

1.6 *This international standard was developed in accordance with internationally recognized principles on standardization established in the Decision on Principles for the Development of International Standards, Guides and Recommendations issued by the World Trade Organization Technical Barriers to Trade (TBT) Committee.*

<sup>1</sup> This test method is under the jurisdiction of ASTM Committee D35 on Geosynthetics and is the direct responsibility of Subcommittee D35.10 on Geomembranes.

Current edition approved Feb. 1, 2018. Published February 2018. Originally approved in 1994. Last previous edition approved in 2014 as D5514/D5514M – 14. DOI: 10.1520/D5514\_D5514M-18.

### 2. Referenced Documents

2.1 *ASTM Standards*:<sup>2</sup>

D792 Test Methods for Density and Specific Gravity (Relative Density) of Plastics by Displacement

D1505 Test Method for Density of Plastics by the Density-Gradient Technique

D2488 Practice for Description and Identification of Soils (Visual-Manual Procedures)

D4439 Terminology for Geosynthetics

D5199 Test Method for Measuring the Nominal Thickness of Geosynthetics

D5261 Test Method for Measuring Mass per Unit Area of Geotextiles

D5994 Test Method for Measuring Core Thickness of Textured Geomembranes

E11 Specification for Woven Wire Test Sieve Cloth and Test Sieves

### 3. Terminology

3.1 *Definitions*:

3.1.1 *atmosphere for testing geomembranes, n*—air maintained at a relative humidity of 50 to 70 % and a temperature of  $21 \pm 2$  °C [ $70 \pm 4$  °F].

3.1.2 *critical height (ch), n*—the maximum exposed height of a cone or pyramid that will not cause a puncture failure of a geosynthetic at a specified hydrostatic pressure for a given period of time.

3.1.3 *failure, n*—in testing geosynthetics, water or air pressure in the test vessel at failure of the geosynthetic.

3.1.4 *hydrostatic pressure, n*—a state of stress in which all the principal stresses are equal (and there is no shear stress), as in a liquid at rest; induced artificially by means of a gaged pressure system; the product of the unit weight of the liquid and the difference in elevation between the given point and the free water elevation.

3.2 For definitions of other terms used in this test method, refer to Terminology D4439.

<sup>2</sup> For referenced ASTM standards, visit the ASTM website, www.astm.org, or contact ASTM Customer Service at service@astm.org. For *Annual Book of ASTM Standards* volume information, refer to the standard's Document Summary page on the ASTM website.

#### 4. Significance and Use

4.1 *Procedure A*—This procedure is an index-type test which can be used as a guide for acceptance of commercial shipments of geosynthetics. The standard cone and pyramid test fixtures can establish critical height (ch) consistency with similar material from previous lots or different suppliers, as well as testing from other laboratories. However, due to the time required to perform tests, it is generally not recommended for routine acceptance testing.

4.2 *Procedures B and C*—These procedures are performance tests intended as a design aid used to simulate the *in-situ* behavior of geosynthetics under hydrostatic compression. These test methods may assist a design engineer in comparing the ability of several candidate geosynthetic materials to conform to a site-specific subgrade under specified use and conditions. In procedure B, the pressure is increased until a failure is observed. In procedure C, a given set of conditions (pressure, temperature and test duration) are maintained constant and the performance of the system is observed at the end of the test.

#### 5. Apparatus

5.1 For safe operation, the test vessel should have an appropriate ASME pressure rating. The maximum pressure rating of the vessel is dependent on the material being tested and expected pressures to be encountered. Pressure can be achieved from a regulated air system or a hydraulic pump.

5.2 *Subgrade Pan*, several removable pans for configuring various subgrades. Subgrade pans are to be built with a depth of 102 mm [4 in.], and with drain holes in the bottom of the pan to allow the pressurizing medium to flow through. The subgrade pan shall be constructed of a suitable material to support a load of 1800 kPa [250 psi].

5.3 *Leak Detection System*, can be designed by using displacement floats, moisture sensor, pressure sensors, a sight glass, or other means that will accurately detect failure.

5.4 *Layout Grid*, for Procedure B, the layout grid is to assist in determining deformation of the tested geosynthetic. The grid is placed flat against the test specimen that has been placed ready for testing. Depth readings will be taken in a prearranged pattern over the entire area of the test specimen. The prearranged area that the geosynthetic displacement depth is checked must remain consistent throughout the complete testing. The depth is taken from the top of the grid to the surface of the test specimen. The layout grid is to be made of 3-mm [0.12-in.] aluminum rod with a grid layout of 50 by 50 mm [2 by 2 in.].

5.5 *Test Cones*—The cones should be manufactured from aluminum or a hard plastic, that is, epoxy or Lexan. They should comply with the dimensions proposed in Fig. 1 and exhibit a smooth surface with no indentation visible with the naked eye.

NOTE 1—An electrical detection system may be used in the cone to facilitate observation of the failure.

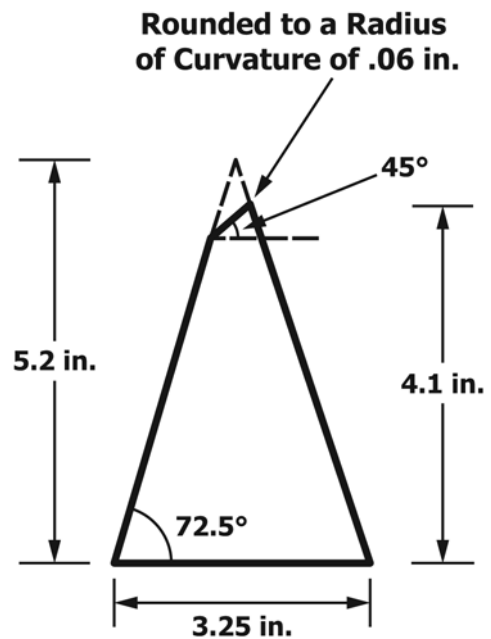

	Nominal Value	Tolerance
Total height of the cone (virtual) (in.)	5.2 in.	5.0 – 5.4 in.
Actual height of the truncated cone (in.)	4.1 in.	4.0 – 4.2 in.
Base diameter (in.)	3.25 in.	3.2 – 3.4 in.
Angle of the conical section (°)	72.5°	72 – 73°
Angle of the top flat portion (°)	45°	44 – 46°
All radius (in.)	0.06 in.	0.04 – 0.08 in.

FIG. 1 Geometry of Cones Used in Procedure A

5.6 Other protrusions such as pyramids may be used, given that they are completely described in the test report. They should be manufactured from aluminum or a hard plastic, that is, epoxy or Lexan.

5.7 *Temperature Probe*, used to measure the test chamber temperature as well as the liquid temperature (if applicable). The accuracy of the temperature probe shall be  $\pm 1$  °C.

5.8 *Support Bridge*, used to support the center of the subgrade pan to keep the pan from deflecting under load.

5.9 *Pressure Measurement Gages*, should be in a series such that each lower pressure can be closed off as its maximum safe operation pressure is reached. The series of gages should be 0 to 210 kPa [0 to 30 psi], 0 to 690 kPa [0 to 100 psi], and 0 to 1400 kPa [0 to 200 psi]. The accuracy shall be  $\pm 7.0$  kPa [1 psi].

#### 6. Hazards

6.1 **Warning**—In addition to other precautions, the test apparatus is under pressure and proper precaution should be taken. When drain valves are opened, safety glasses should be worn by the operator. Pressure relief valves are highly recommended to prevent unsafe pressures.

#### 7. Test Specimen

7.1 Cut the geosynthetic test specimen to fit a minimum of 10 mm beyond the clamping area (test vessel flange area) of the designed pressure vessel.

NOTE 2—The conceptual drawing of a pressure vessel as diagrammed in Fig. 2 is acceptable, however, other types of vessels can be used as long as the size does not bias results for a particular material.

NOTE 3—If it is difficult to determine a materials machine direction after testing, first mark on the specimen before testing a line parallel to the machine direction.

7.2 Measure the geosynthetic specimen thickness accurately by one of the industry-standard test methods referenced in Section 2.

NOTE 4—If testing a permeable geosynthetic without the support of a geomembrane, a non-permeable sheet on the liquid medium side may be used, provided adjustments are made for the strength of the non-permeable sheet (that is, 0.4-mm latex).

7.3 The test specimen should be free of any scratches, folds, or other abnormalities, unless the abnormality is the item of interest.

7.4 Examine a total of three replicate test specimens.

**8. Conditioning**

8.1 Expose the specimens to the standard atmosphere for testing geomembranes for a period long enough to allow the geomembranes to reach equilibrium with the standard atmosphere. Consider the specimen to be at moisture equilibrium when the change in mass of the specimen in successive weightings made at intervals of not less than 2 h does not exceed 0.1 % of the mass of the specimen. Consider the specimen to be at temperature equilibrium after 1 h of exposure to the standard atmosphere for testing.

8.2 If the test is to simulate actual application, the test specimen should be conditioned for at least 40 h in that

environment. If there is not a specific environment, then the conditioning should be in accordance with ASTM standard conditioning for the material being tested. If no such standard exists, state the conditioning procedure used.

**9. Procedure A**

9.1 *Placement of the Subgrade*—First place a geotextile or other fabric in the bottom of the subgrade pan. The geotextile is to be used to restrict movement of small particles of sand or rocks into the lower portion of the tester. Any geotextile or other fabric which has the capability of retaining the subgrade pan fill material and does not restrict the flow of the liquid medium is adequate.

NOTE 5—The use of any geotextile should not allow movement of the pyramids or cones in relation to the established subgrade. This movement could result in changes in the protrusion height during the test.

9.2 Place the pyramids/cones in the subgrade pan on top of the geotextile. The pyramids/cones are arranged so that a line drawn through the geometric center of the pyramid/cone is on a circumference of a 200-mm [8-in.] diameter circle for a 500-mm [20-in.] minimum diameter vessel.

9.3 If pyramids are selected, four test pyramids shall be used for each test. The pyramids are positioned 90° apart.

9.4 If cones are selected, three test cones shall be used for each test. The cones are arranged 120° apart with their 45° faces each facing the center of the pan.

9.5 The subgrade shall be a clean, washed, Ottawa sand used to support the geomembrane materials at final placement

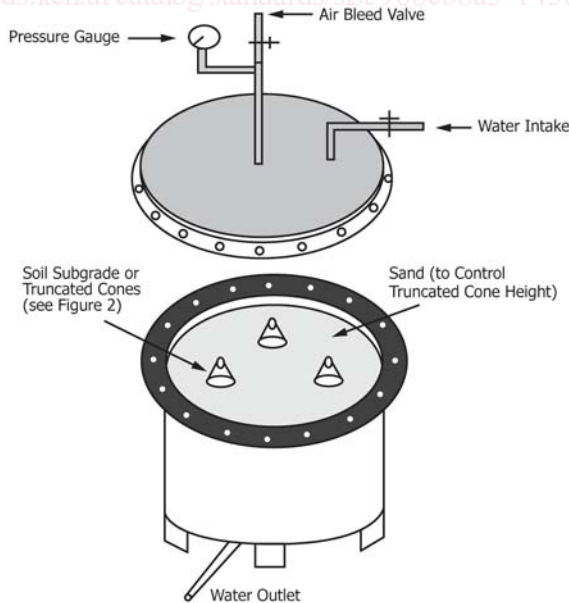

**a. Schematic Drawing**



**b. Photograph**

**FIG. 2 Experimental Test Apparatus**