



Designation: D6244 – 06 (Reapproved 2018)

# Standard Test Method for Vertical Compression of Geocomposite Pavement Panel Drains<sup>1</sup>

This standard is issued under the fixed designation D6244; the number immediately following the designation indicates the year of original adoption or, in the case of revision, the year of last revision. A number in parentheses indicates the year of last reapproval. A superscript epsilon ( $\epsilon$ ) indicates an editorial change since the last revision or reapproval.

## 1. Scope

1.1 This test method covers vertical strain and core area change of geocomposite pavement drains, such as those included in Specification D7001, under vertical compression.

1.2 The values as stated in SI units are to be regarded as the standard. The values given in parentheses are for information only.

1.3 *This standard does not purport to address all of the safety concerns, if any, associated with its use. It is the responsibility of the user of this standard to establish appropriate safety, health, and environmental practices and determine the applicability of regulatory limitations prior to use.*

1.4 *This international standard was developed in accordance with internationally recognized principles on standardization established in the Decision on Principles for the Development of International Standards, Guides and Recommendations issued by the World Trade Organization Technical Barriers to Trade (TBT) Committee.*

## 2. Referenced Documents

2.1 *ASTM Standards:*<sup>2</sup>

- D1566 Terminology Relating to Rubber
- D4354 Practice for Sampling of Geosynthetics and Rolled Erosion Control Products (RECPs) for Testing
- D4439 Terminology for Geosynthetics
- D7001 Specification for Geocomposites for Pavement Edge Drains and Other High-Flow Applications

## 3. Terminology

3.1 *Definitions of Terms Specific to This Standard:*

3.1.1 *compressive deformation, n*—the decrease in gage length produced in the test specimen by a compressive load, expressed in units of length (new).

<sup>1</sup> This test method is under the jurisdiction of ASTM Committee D35 on Geosynthetics and is the direct responsibility of Subcommittee D35.01 on Mechanical Properties.

Current edition approved Feb. 1, 2018. Published February 2018. Originally approved in 1998. Last previous edition approved in 2011 as D6244 – 06 (2011). DOI: 10.1520/D6244-06R18.

<sup>2</sup> For referenced ASTM standards, visit the ASTM website, www.astm.org, or contact ASTM Customer Service at service@astm.org. For *Annual Book of ASTM Standards* volume information, refer to the standard's Document Summary page on the ASTM website.

3.1.2 *compressive strain, n*—the ratio of compressive deformation to the gage length of the test specimen, expressed as a dimensionless ratio (new).

3.1.3 *gage length, n*—the known distance between two benchmarks (see Terminology D1566).

3.1.3.1 *Discussion*—In compression testing of geosynthetics, gage length is the measured thickness of the test specimen under specified compressional force, expressed in units of length.

3.1.4 *geosynthetic, n*—a planar product manufactured from polymeric material used with foundation, soil, rock, earth, or any other geotechnical engineering-related materials as an integral part of a manmade project, structure, or system (see Terminology D4439).

3.1.5 *index test, n*—a test procedure which may contain a known bias but which may be used to order a set of specimens with respect to the property of interest (see Terminology D4439).

## 4. Summary of Test Method

4.1 Geocomposite pavement edge drains are placed into a 304.8-mm (12-in.) long, 106.7-mm (4.20-in.) wide, and 610-mm (24-in.) tall glass and aluminum compression chamber. The geocomposites are placed against the wall of the chamber. The remainder of the chamber is then backfilled with a specified sand. A vertical load is applied at a constant rate. The vertical strains of the panels and change in core area and height is recorded at 1112.5-N (250-lb) increments. The test is discontinued at 4450 N (1000 lb) or 156.5 kPa (22.7 psi). The change in vertical strain, core height, and core area is determined.

## 5. Significance and Use

5.1 The vertical compression test for geocomposite pavement panel drains is intended to simulate vertical, horizontal, and eccentric loading resulting from an applied vertical load. The results of the analyses, including vertical strain of the panels and core area change, may be used as an index test. The vertical compression test may be used to evaluate core area change for a given load.

5.2 The vertical compression test may be used to evaluate percent vertical strain for a given load.

5.3 This test method may be modified to evaluate core area change and vertical strain under various backfill conditions.

6. Apparatus

6.1 *Compression Machine*—A compression machine that is capable of producing at least 4450 N (1000 lb) of load. The

machine must be capable of loading at a rate of 445 N (100 lb)/min, and maintaining a constant load for an indefinite period.

6.2 *Compression Box*—The box must be capable of holding the specimen and the backfill material, and it must be capable of supporting a minimum vertical load of 4450 N (1000 lb).

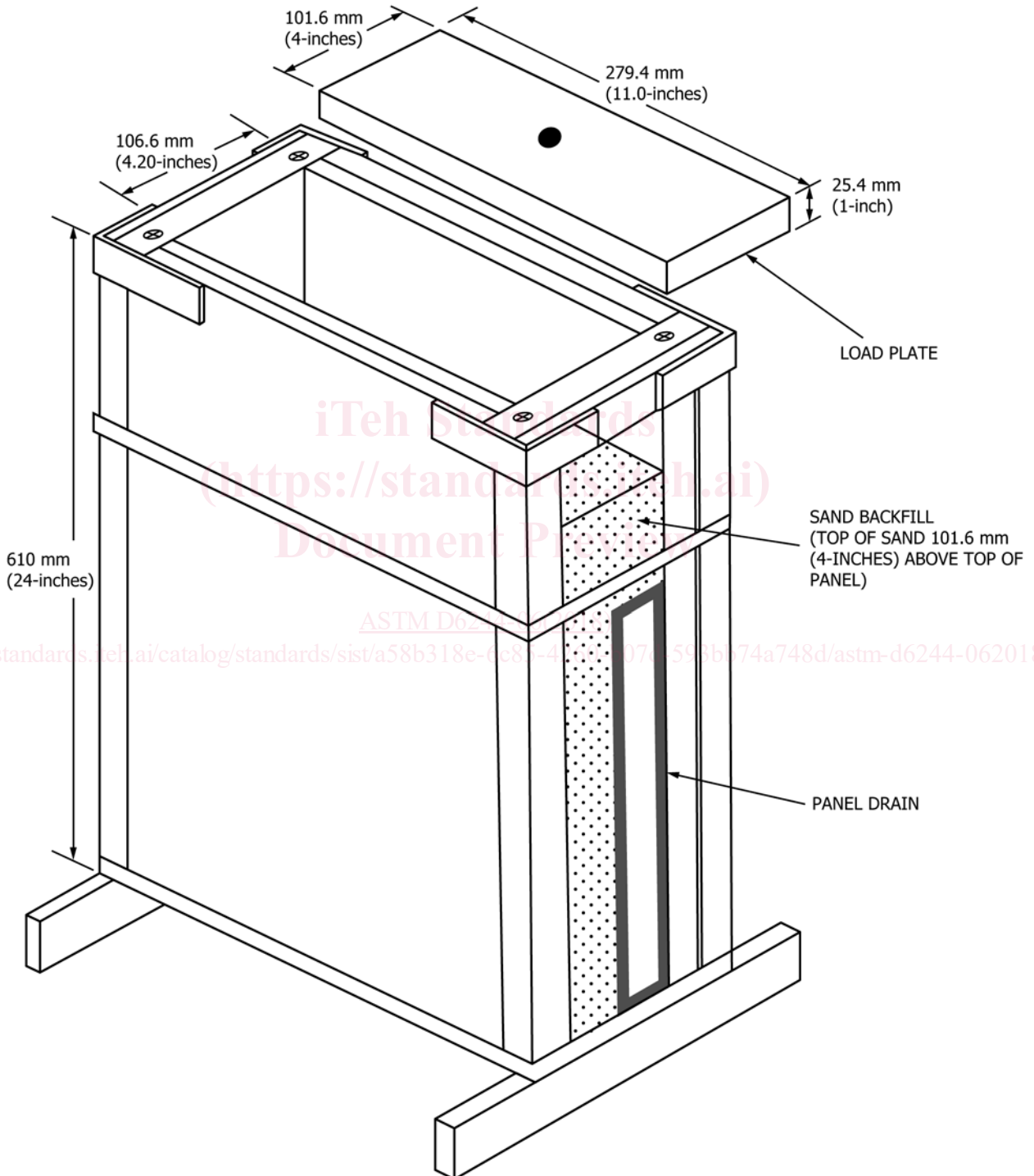

FIG. 1 Edge Drain Compression Chamber