



Designation: **C1786—17 C1786 – 18**

Standard Specification for Segmental Precast Reinforced Concrete Box Sections for Culverts, Storm Drains, and Sewers Designed According to AASHTO LRFD¹

This standard is issued under the fixed designation C1786; the number immediately following the designation indicates the year of original adoption or, in the case of revision, the year of last revision. A number in parentheses indicates the year of last reapproval. A superscript epsilon (ϵ) indicates an editorial change since the last revision or reapproval.

1. ~~Scope~~ Scope*

1.1 This specification covers precast reinforced concrete box sections comprised of separate segments that once properly field assembled make the final structure. These structures are intended to be used for the construction of culverts and for the conveyance of storm water, industrial wastes and sewage.

NOTE 1—This specification is primarily a manufacturing and purchasing specification. However, box culverts manufactured to this standard are intended to meet the design requirements of the AASHTO LRFD Bridge Design Specifications, and as such, design guidance is included in [Appendix X1](#).

NOTE 2—The successful performance of this product depends upon the proper selection of the box section, bedding, backfill, and care that the installation conforms to the construction specifications. The purchaser of the precast reinforced concrete box sections specified herein is cautioned that proper correlation of the loading conditions and the field requirements with the box section specified, and provision for inspection at the construction site, are required.

1.2 The values stated in inch-pound units are to be regarded as standard. No other units of measurement are included in this standard.

1.3 *This international standard was developed in accordance with internationally recognized principles on standardization established in the Decision on Principles for the Development of International Standards, Guides and Recommendations issued by the World Trade Organization Technical Barriers to Trade (TBT) Committee.*

2. Referenced Documents

2.1 ASTM Standards:²

- [A615/A615M Specification for Deformed and Plain Carbon-Steel Bars for Concrete Reinforcement](#)
- [A706/A706M Specification for Deformed and Plain Low-Alloy Steel Bars for Concrete Reinforcement](#)
- [A1064/A1064M Specification for Carbon-Steel Wire and Welded Wire Reinforcement, Plain and Deformed, for Concrete](#)
- [C33/C33M Specification for Concrete Aggregates](#)
- [C150/C150M Specification for Portland Cement](#)
- [C260/C260M Specification for Air-Entraining Admixtures for Concrete](#)
- [C309 Specification for Liquid Membrane-Forming Compounds for Curing Concrete](#)
- [C494/C494M Specification for Chemical Admixtures for Concrete](#)
- [C497 Test Methods for Concrete Pipe, Manhole Sections, or Tile](#)
- [C595/C595M Specification for Blended Hydraulic Cements](#)
- [C618 Specification for Coal Fly Ash and Raw or Calcined Natural Pozzolan for Use in Concrete](#)
- [C822 Terminology Relating to Concrete Pipe and Related Products](#)
- [C989/C989M Specification for Slag Cement for Use in Concrete and Mortars](#)
- [C1017/C1017M Specification for Chemical Admixtures for Use in Producing Flowing Concrete](#)
- [C1116/C1116M Specification for Fiber-Reinforced Concrete](#)
- [C1602/C1602M Specification for Mixing Water Used in the Production of Hydraulic Cement Concrete](#)

¹ This test method is under the jurisdiction of ASTM Committee C13 on Concrete Pipe and is the direct responsibility of Subcommittee C13.07 on Acceptance Specifications and Precast Concrete Box Sections.

Current edition approved Oct. 1, 2017; Jan. 1, 2018. Published October 2017/February 2018. Originally approved in 2014. Last previous edition approved in 2016 as C1786 – 16:17. DOI: 10.1520/C1786-17.10.1520/C1786-18.

² For referenced ASTM standards, visit the ASTM website, www.astm.org, or contact ASTM Customer Service at service@astm.org. For *Annual Book of ASTM Standards* volume information, refer to the standard's Document Summary page on the ASTM website.

*A Summary of Changes section appears at the end of this standard

2.2 AASHTO Standards:³

AASHTO LRFD Bridge Design Specifications
AASHTO LRFD Bridge Construction Specifications

2.3 ACI Standards:⁴

ACI 318 Building Code Requirements for Structural Concrete

3. Terminology

3.1 Definitions of Terms Specific to This Standard:

3.1.1 *box section*—the completed box culvert unit with all segments adjoined (see Fig. 1 for configuration options).

3.1.2 *box segment*—the individual piece (top slab, bottom slab, or three-sided structure) that gets adjoined to other pieces to complete the final box section

3.2 *Definitions*—For definitions of terms relating to concrete box culvert sections not found above, see Terminology C822.

4. Basis of Acceptance

4.1 Acceptability of the box sections produced in accordance with this standard shall be determined by the results of the concrete compressive strength tests described in Section 10, by the material requirements described in Section 5, and by inspection of the finished box sections by the owner or their designee.

NOTE 3—The box culvert structure itself is not complete until it is fully assembled in the field. Field assembly is not included in this specification. However, a final field inspection is recommended before the box culvert is considered fit for duty.

5. Material

5.1 *Reinforced Concrete*—The reinforced concrete shall consist of cementitious materials, mineral aggregates, admixtures if used, and water, in which steel has been embedded in such a manner that the steel and concrete act together.

5.2 Cementitious Materials:

5.2.1 *Cement*—Cement shall conform to the requirements for portland cement of Specification C150/C150M or shall be portland blast-furnace slag cement, portland-limestone cement, or portland-pozzolan cement conforming to the requirements of Specification C595/C595M, except that the pozzolan constituent in the Type IP portland-pozzolan cement shall be fly ash.

5.2.2 *Fly Ash*—Fly ash shall conform to the requirements of Specification C618, Class F or Class C.

5.2.3 *Slag Cement*—Slag cement shall conform to the requirements of Grade 100 or 120 of Specification C989/C989M.

5.2.4 *Allowable Combinations of Cementitious Materials*—The combination of cementitious materials used in concrete shall be one of the following:

5.2.4.1 Portland cement only,

5.2.4.2 Portland blast-furnace slag cement only,

5.2.4.3 Portland-pozzolan cement only,

5.2.4.4 Portland-limestone cement only,

5.2.4.5 A combination of portland cement or portland-limestone cement and fly ash,

5.2.4.6 A combination of portland cement or portland-limestone cement and slag cement, or

5.2.4.7 A combination of portland cement or portland-limestone cement, slag cement, and fly ash, or

5.2.4.8 A combination of portland-pozzolan cement and fly ash.

5.3 *Aggregates*—Aggregates shall conform to Specification C33/C33M, except that the requirements for gradation shall not apply.

5.4 *Admixtures*—The following admixtures and blends are allowable:

5.4.1 Air-entraining admixture conforming to Specification C260/C260M;

5.4.2 Chemical admixture conforming to Specification C494/C494M;

5.4.3 Chemical admixture for use in producing flowing concrete conforming to Specification C1017/C1017M.

5.4.4 Chemical admixture or blend approved by the owner.

5.5 *Steel Reinforcement*—Reinforcement shall consist of welded wire reinforcement conforming to Specification A1064/A1064M or billet-steel bars conforming to Specification A615/A615M, Grade 60 or A706/A706M, Grade 60. The box culvert segments shall be manufactured with reinforcement meeting the yield strengths designated in the design of the box culvert, but the yield strength shall not be less than 60 ksi.

³ Available from American Association of State Highway and Transportation Officials (AASHTO), 444 N. Capitol St., NW, Suite 249, Washington, DC 20001, <http://www.transportation.org>.

⁴ Available from American Concrete Institute (ACI), P.O. Box 9094, Farmington Hills, MI 48333-9094, <http://www.concrete.org>.

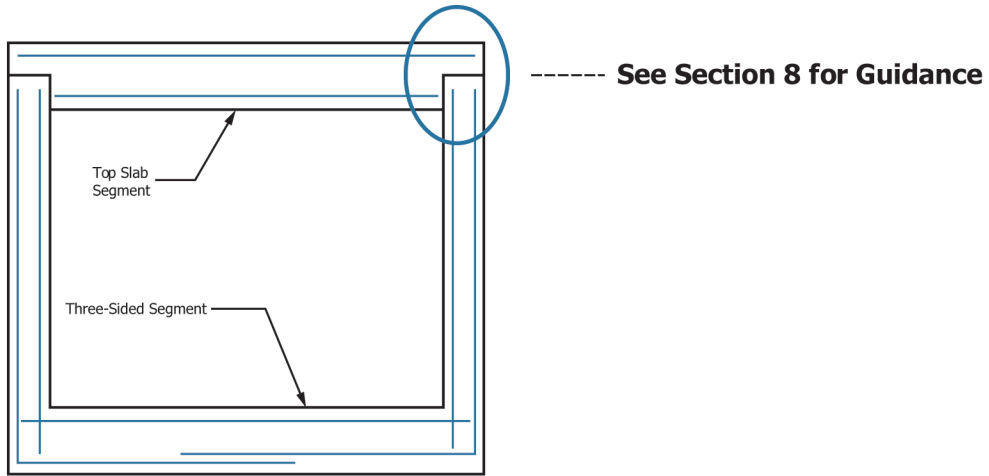

Three-sided Section with Top Slab Segment

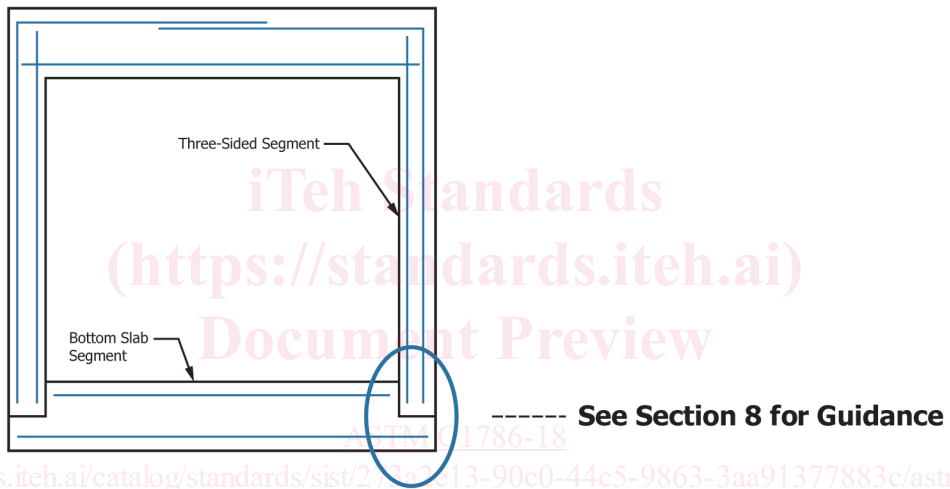

Three-sided Section with Bottom Slab Segment

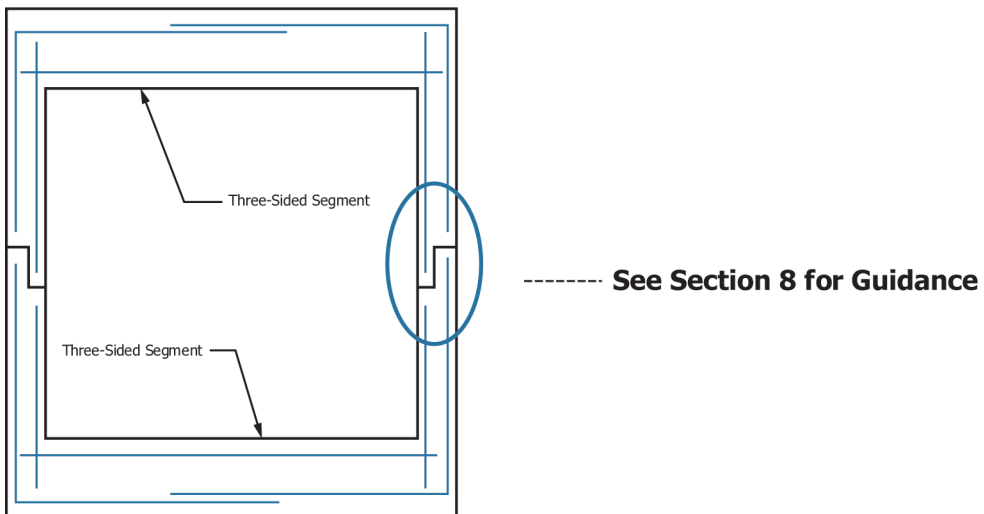

Double Three-sided (Clamshell) Configuration

FIG. 1 Segment Configuration Options

5.6 *Fibers*—Synthetic and non-synthetic fibers shall be allowed to be used, at the manufacturer’s option, in concrete boxes as a nonstructural manufacturing material. Synthetic fibers (Type II and Type III) and non-synthetic fiber (Type I) designed and manufactured specifically for use in concrete and conforming to the requirements of Specification C1116/C1116M shall be accepted.

5.7 *Water*—Water used in the production of concrete shall be potable, or non-potable water that meets the requirements of Specification C1602/C1602M.

6. Design

6.1 Each segment of the box shall meet the requirements of the AASHTO LRFD Bridge Design Specifications. Guidance is given in Appendix XI.

6.2 The manufacturer shall maintain on file a copy of a sealed “stamped” design by a professional engineer in accordance with the AASHTO LRFD Bridge Design Specifications and this standard for each structure manufactured.

6.3 The minimum compressive strength of concrete segments produced to this standard shall be 4000 psi, unless otherwise designated by the engineer.

6.4 The manufacturer shall produce box culvert segments meeting the design requirements designated in the design of the segmental precast box structure. As a minimum, the box culvert segments shall meet the reinforcement layout, concrete cover, and all other manufacturing details required by this standard.

6.5 The manufacturer may request approval by the purchaser for modified designs which differ from the requirements in this standard. When such modified designs are approved, it shall be so indicated on the manufactured box with the designation “C1786–Modified.”

NOTE 4—(Advisory)—Construction procedures, such as heavy equipment movement or stockpiling of material over or adjacent to a box structure can induce higher loads than those used for the structure’s final design. These construction and surcharge loads are allowable as long as the final steel areas in the box are equal to or larger than those required for the construction phase. The design engineer shall take into consideration the potential for higher loads induced by construction procedures in determining the final design of the box structure.

7. Reinforcement

7.1 *Placement of Reinforcement*—Reinforcement shall be assembled utilizing any combination of single or multiple layers of welded wire reinforcement, not to exceed three layers, or utilizing single or double layers of deformed billet steel bars. The cover of concrete over the circumferential reinforcement shall be 1 in. except for when the box culvert has less than 2 ft of earth cover, then the concrete cover over the top slab reinforcement shall be 2 inches (see Figs. 2 and 3). Concrete cover shall be subject to the provisions of Section 11. The welded wire reinforcement shall be composed of circumferential and longitudinal wires meeting the spacing requirements of 7.2 and shall contain sufficient longitudinal wires extending through the box section to maintain the shape and position of reinforcement. Longitudinal distribution reinforcement shall be welded-wire reinforcement or deformed

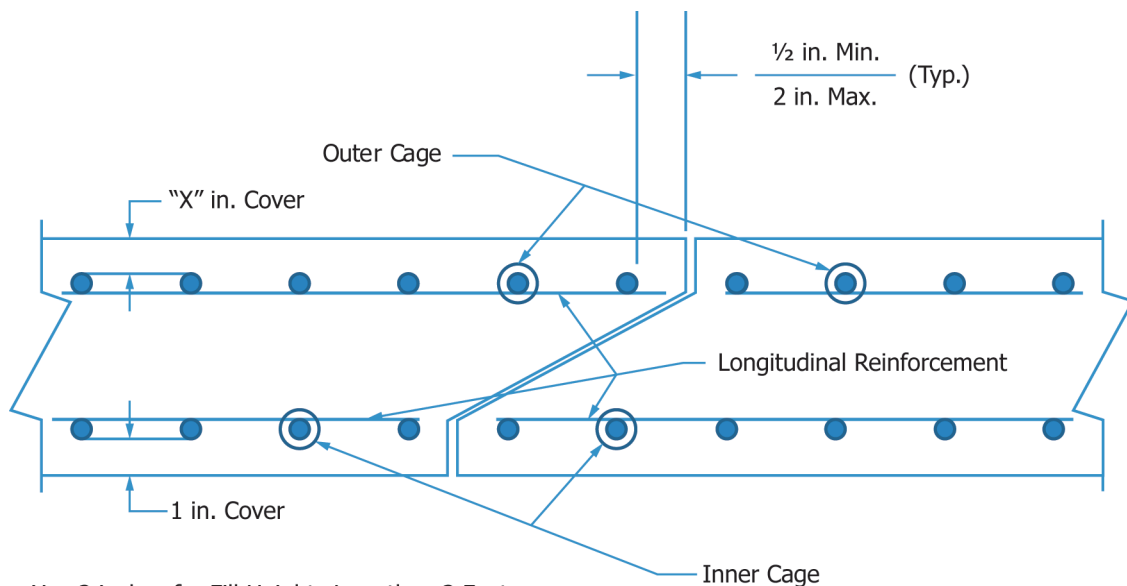

X = 2 inches for Fill Heights Less than 2 Feet.
 X = 1 inch for Fill Heights 2 Feet and Greater

FIG. 2 Top Slab Reinforcement Placement
 (Joint configuration is for illustration purposes only, and other configurations are acceptable.)

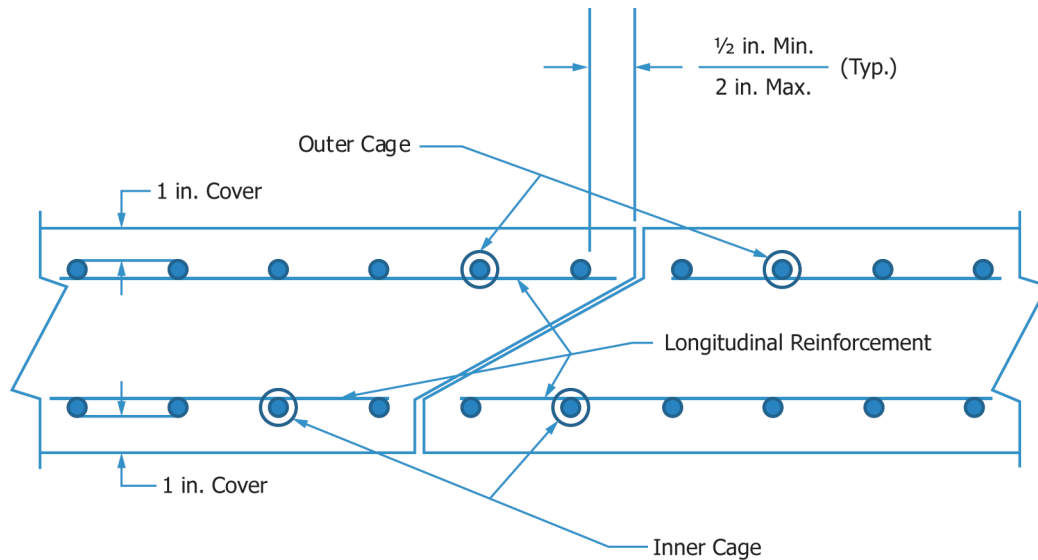

FIG. 3 Bottom Slab Reinforcement Placement
(Joint configuration is for illustration purposes only, and other configurations are acceptable.)

billet-steel bars and shall meet the spacing requirements of 7.2. The ends of the longitudinal distribution reinforcement shall not be more than 2 in. from the ends of the box section. The exposure of the ends of longitudinals, stirrups, and spacers used to position the reinforcement shall not be a cause for rejection.

7.2 Laps, Welds, and Spacing—When deformed billet steel bars are utilized for the primary reinforcing, the requirements in the AASHTO LRFD Bridge Design Specifications, Section 5.11 for splices and development of reinforcement shall be followed. When wire reinforcement is utilized, the requirements of this section shall be followed. Splices in the circumferential reinforcement shall be made by lapping. The overlap measured between the outermost longitudinal wires of each reinforcement sheet shall not be less than the space containing two longitudinal wires of each mesh plus 2 in., but not less than 10 inches. No splicing is permitted in individual slab segments. The outside circumferential reinforcement in the top or bottom slab of a three-sided segment shall be continuous with, or lapped with the outside circumferential reinforcement in the sides. If welds are made to welded wire circumferential reinforcement, they shall be made only to selected circumferential wires that are not less than 18 in. apart along the longitudinal axis of the three-sided section. When spacers are welded to circumferential wires, they shall be welded only to these selected circumferential wires. There shall be no welding to other circumferential wires. No welds shall be made to the inside circumferential wires in the middle third of the top span. No welds shall be made to the outside circumferential wires in the top span within one fourth of the span from the corners or in any location in either leg. Welding of deformed billet steel bar circumferential reinforcement is prohibited in all cases. When distribution reinforcement is fastened to a cage by welding, it shall be welded only to longitudinal wires or bars and only near the ends of the three-sided section. The spacing center to center of the circumferential reinforcement shall not be less than 2 in. nor more than 4 in. for welded wire reinforcement, or less than 2 in. nor more than 8 in. for deformed billet steel bars. The spacing center to center of the longitudinal reinforcement shall not be more than 8 in. for welded wire reinforcement or more than 12 in. for deformed billet steel bars. If welds are made to Grade 60 reinforcing bars, weldable bars conforming to Specification A706/A706M shall be used.

NOTE 5—(Advisory)—The AASHTO LRFD Bridge Design Specifications should be consulted for weld requirements and development lengths not directly addressed in this standard.

7.3 Minimum Reinforcement—Box culvert sections with less than 2 ft of earth or pavement cover shall contain distribution reinforcement in the bottom of the top slab in accordance with Article 9.7.3.2 of the AASHTO LRFD Bridge Design Specifications, but shall be no less than $0.002 \cdot A_g$ in accordance with Article 12.11.4.3.

8. Joints

8.1 The ends of the box segments shall be of such design that each segment can be fitted together to form a complete box section unit. The ends of the box section units shall be so formed that the sections can be laid together to make a continuous line of box sections compatible with the permissible variations given in Section 11.

8.2 Longitudinal joints shall be designed to carry the applied vertical forces, and so formed so that they can be assembled to transmit forces and provide joint tightness consistent with the requirements for transverse joints.

9. Manufacture

9.1 **Mixture**—The aggregates shall be sized, graded, proportioned, and mixed with such proportions of cementitious materials and water as will produce a thoroughly mixed concrete of such quality that the box section will conform to the test and design

requirements of this specification. All concrete shall have a water-cementitious materials ratio not exceeding 0.50 by weight. Cementitious materials shall be as specified in 5.2 and shall be added to the mix in a proportion not less than 470 lb/yd³ unless mix designs with a lower cementitious materials content demonstrate that the quality and performance of the box section meet the requirements of this specification.

9.2 *Curing*—The box segments shall be cured for a sufficient length of time so that the concrete will develop the specified compressive strength by the time of delivery. Any one of the following methods of curing or combinations thereof shall be used:

9.2.1 *Steam Curing*—The box segments shall be low pressure, steam-cured by a system that will maintain a moist atmosphere.

9.2.2 *Water Curing*—The box segments shall be water-cured by any method that will keep the sections moist.

9.2.3 *Membrane Curing*—A sealing membrane conforming to the requirements of Specification C309 shall be applied and shall be left intact until the required concrete compressive strength is attained. The concrete temperature at the time of application shall be within 10°F of the atmospheric temperature. All surfaces shall be kept moist prior to the application of the compounds and shall be damp when the compound is applied.

9.3 *Forms*—The forms used in manufacture shall be sufficiently rigid and accurate to maintain the box section dimensions within the permissible variations given in Section 10. All casting surfaces shall be of smooth nonporous material.

9.4 *Handling*—Handling devices or holes are not prohibited in each box segment for the purpose of handling and laying.

10. Physical Requirements

10.1 *Type of Test Specimen*—Compression tests for determining concrete compressive strength shall be allowed to be made on either standard rodded concrete cylinders or concrete cylinders compacted and cured in like manner as the box segments, or on cores drilled from the box section.

10.2 *Compression Testing of Cylinders:*

10.2.1 Cylinders shall be prepared, cured, and tested in accordance with Section 11 of Test Methods C494/C494M. Cylinders shall be exposed to the same curing conditions as the manufactured box segments and shall remain with the segments until tested.

10.2.2 Prepare not less than three test cylinders from each concrete mix used within a lot (one day's production) of box segments.

10.2.3 *Acceptability on the Basis of Cylinder Test Results:*

10.2.3.1 When the average compressive strength of all cylinders tested is equal to or greater than the design concrete strength, not more than 10 % of the cylinders tested have a compressive strength less than the design concrete strength, and no cylinder tested has a compressive strength less than 80 % of the design concrete strength, the lot shall be accepted.

10.2.3.2 Box segments that fail to meet the strength requirements under 10.2 shall not be retested under 10.3 without the approval of the purchaser.

10.2.3.3 When the compressive strength of the cylinders is unavailable, the acceptability of the lot shall be determined in accordance with the provisions of 10.3.

10.3 *Compression Testing of Cores:*

10.3.1 Cores shall be obtained, prepared, and tested for compressive strength in accordance with the provisions of Test Methods C497.

10.3.2 Three separate box sections shall be selected at random from each group of 15 box sections or fraction thereof, of a single size from each continuous production run. Cores shall be taken from each individual box segment comprising the full box section.

10.3.3 *Acceptability by Core Tests:*

10.3.3.1 Concrete represented by these core tests shall be considered acceptable if the average of the core strengths is equal to or greater than 85 % of the required compressive strength of the concrete with no one core less than 75 % of the required compressive strength.

10.3.3.2 If the compressive strength of the cores does not meet the requirements of 10.3.3.1, the individual segment from which the cores were taken shall be rejected. Two additional box segments from the remainder of that segment group (bottom slab, top slab, or three-sided) shall be selected at random and one core shall be taken from each and tested. If both cores have a strength equal to or greater than 85 % of the required strength, the remainder of the group is acceptable. If the compressive strength of either of the two cores tested is less than 85 % of the required strength of the concrete, the remainder of the group of box segments shall be rejected, or, at the option of the manufacturer, each box segment of the remainder of the group shall be cored and accepted individually, and any of these box segments that have core strengths less than 85 % of the required strength of the concrete shall be rejected.

NOTE 6—(Advisory)—The percentage shown for acceptance of core tests are in accordance with ACI 318 which states that, “To expect core tests to be equal to f'_c is not realistic, since differences in the size of specimens, conditions of obtaining samples, and procedures for curing do not permit equal values to be obtained.” The variations of the specimens such as length to diameter ratio, drilling direction and process, aggregate size and sample preparation may all have an effect on the test results. Embedded steel reinforcement affects the test results because of the loss of concrete continuity.

10.4 *Plugging Core Holes*—The core holes shall be plugged and sealed by the manufacturer in a manner such that the box section will meet all of the test requirements of this specification. Box sections so sealed shall be considered as satisfactory for use.