



Designation: **C1332 – 01 (Reapproved 2013) C1332 – 18**

Standard Test Method Practice for Measurement of Ultrasonic Attenuation Coefficients of Advanced Ceramics by Pulse-Echo Contact Technique¹

This standard is issued under the fixed designation C1332; the number immediately following the designation indicates the year of original adoption or, in the case of revision, the year of last revision. A number in parentheses indicates the year of last reapproval. A superscript epsilon (ϵ) indicates an editorial change since the last revision or reapproval.

1. Scope-~~Scope~~*

1.1 This ~~test method practice~~ describes a procedure for measurement of ultrasonic attenuation coefficients for advanced structural ceramic materials. The procedure is based on a broadband buffered piezoelectric probe used in the pulse-echo contact mode and emitting either longitudinal or shear waves. The primary objective of this ~~test method practice~~ is materials characterization.

1.2 The procedure requires coupling an ultrasonic probe to the surface of a plate-like sample and the recovery of successive front surface and back surface ~~echoes~~-echoes (refer to Fig. 3). Power spectra of the echoes are used to calculate the attenuation spectrum (attenuation coefficient as a function of ultrasonic frequency) for the sample material. The transducer bandwidth and spectral response are selected to cover a range of frequencies and corresponding wavelengths that interact with microstructural features of interest in solid test samples.

1.3 The purpose of this ~~test method practice~~ is to establish fundamental procedures for measurement of ultrasonic attenuation coefficients. These measurements should distinguish and quantify microstructural differences among solid samples and therefore help establish a reference database for comparing materials and calibrating ultrasonic attenuation measurement equipment.

1.4 This ~~test method practice~~ applies to monolithic ceramics and also polycrystalline metals. This ~~test method practice~~ may be applied to whisker reinforced ceramics, particulate toughened ceramics, and ceramic composites provided that similar constraints on sample size, shape, and finish are met as described herein for monolithic ceramics.

1.5 This ~~test method practice~~ sets forth the constraints on sample size, shape, and finish that will assure valid attenuation coefficient measurements. This ~~test method practice~~ also describes the instrumentation, methods, and data processing procedures for accomplishing the measurements.

1.6 This ~~test method practice~~ is not recommended for highly attenuating materials such as very thick, very porous, rough-surfaced monolithics or composites. This ~~test method practice~~ is not recommended for highly nonuniform, heterogeneous, cracked, defective, or otherwise flaw-ridden samples that are unrepresentative of the nature or inherent characteristics of the material under examination.

1.7 *This standard does not purport to address all of the safety concerns, if any, associated with its use. It is the responsibility of the user of this standard to establish appropriate ~~safety~~-safety, health, and ~~health~~environmental practices and determine the applicability of regulatory limitations prior to use.*

1.8 *This international standard was developed in accordance with internationally recognized principles on standardization established in the Decision on Principles for the Development of International Standards, Guides and Recommendations issued by the World Trade Organization Technical Barriers to Trade (TBT) Committee.*

2. Referenced Documents

2.1 *ASTM Standards:*²

[C1331 Practice for Measuring Ultrasonic Velocity in Advanced Ceramics with Broadband Pulse-Echo Cross-Correlation Method](#)
[E543 Specification for Agencies Performing Nondestructive Testing](#)

¹ This ~~test method practice~~ is under the jurisdiction of ASTM Committee E07 on Nondestructive Testing and is the direct responsibility of Subcommittee E07.06 on Ultrasonic Method.

Current edition approved Feb. 1, 2013Feb. 1, 2018, Published April 2013February 2018. Originally approved in 1996. Last previous edition approved in 20072013 as C1332C1332 – 01 (2013), – 01 (2007). DOI: 10.1520/C1332-01R13, DOI: 10.1520/C1332-18.

² For referenced ASTM standards, visit the ASTM website, www.astm.org, or contact ASTM Customer Service at service@astm.org. For *Annual Book of ASTM Standards* volume information, refer to the standard's Document Summary page on the ASTM website.

*A Summary of Changes section appears at the end of this standard

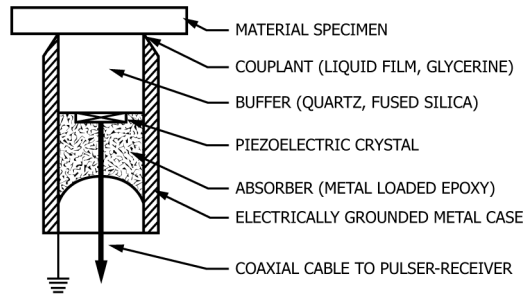

FIG. 1 Cross Section of Buffered Broadband Ultrasonic Probe

[E664/E664M Practice for the Measurement of the Apparent Attenuation of Longitudinal Ultrasonic Waves by Immersion Method](#)

[E1316 Terminology for Nondestructive Examinations](#)

[E1495/E1495M Guide for Acousto-Ultrasonic Assessment of Composites, Laminates, and Bonded Joints](#)

2.2 ~~ASNT Document: Documents:~~³

[Recommended Practice SNT-TC-1A for Nondestructive Testing Personnel Qualification and Certification](#)

[ANSI/ASNT CP-189 Standard for Qualification and Certification of Nondestructive Testing Personnel](#)

2.3 ~~Military ISO Standard:~~

~~[MH-STD-410 ISO 9712 Nondestructive Testing Personnel Qualification Non-destructive Testing – Qualification and Certification of NDT Personnel](#)~~⁴

2.4 ~~Aerospace Industries Association Document:~~

~~[NAS 410 Certification and Qualification of Nondestructive Testing Personnel](#)~~⁵

2.5 ~~Additional references are cited in the text and at end of this test method: practice.~~

3. Terminology

3.1 *Definitions of Terms Specific to This Standard:*

3.1.1 *acoustic impedance (Z)*—a property **(1)**⁶ defined by a material's density, p , and the velocity of sound within it, v , where $Z = \rho v$.

3.1.2 *attenuation coefficient (α)*—decrease in ultrasound intensity with distance expressed in nepers (Np) per unit length, herein, $\alpha = [\ln(I_0/I)]/d$, where α is attenuation coefficient, d is path length or distance, I_0 is original intensity and I is attenuated intensity **(2)**.

3.1.3 *attenuation spectrum*—the attenuation coefficient, α , expressed as a function of ultrasonic frequency, f , or plotted as α versus f , over a range of ultrasonic frequencies within the bandwidth of the transducer and associated pulser-receiver instrumentation.

3.1.4 *back surface*—the surface of a test sample which is opposite to the front surface and from which back surface echoes are returned at normal incidence directly to the transducer.

3.1.5 *bandwidth*—the frequency range of an ultrasonic probe, defined by convention as the difference between the lower and upper frequencies at which the signal amplitude is 6 dB down from the frequency at which maximum signal amplitude occurs. The frequency at which the maximum occurs is termed the *center frequency* of the probe or transducer.

3.1.6 *broadband transducer*—an ultrasonic transducer capable of sending and receiving undistorted signals over a broad bandwidth, consisting of thin damped piezoelectric crystal in a buffered probe (search unit).

3.1.7 *buffered probe*—an ultrasonic search unit as defined in Terminology [E1316](#) but containing a delay line or buffer rod to which the piezoelement, that is, transducer consisting of a piezoelectric crystal, is affixed. The buffer rod separates the piezoelement from the test sample (see [Fig. 1](#)).

3.1.8 *buffer rod*—an integral part of a buffered probe or search unit, usually a quartz or fused silica cylinder that provides a time delay between the excitation pulse from the piezoelement and echoes returning from a sample coupled to the free end of the buffer rod.

³ Available from American Society for Nondestructive Testing (ASNT), P.O. Box 28518, 1711 Arlingate Ln., Columbus, OH 43228-0518, <http://www.asnt.org>.

⁴ Available from Standardization Documents Order Desk, DODSSP, Bldg. 4, Section D, 700 Robbins Ave., Philadelphia, PA 19111-5098, <http://www.dodssp.daps.mil>; International Organization for Standardization (ISO), ISO Central Secretariat, BIBC II, Chemin de Blandonnet 8, CP 401, 1214 Vernier, Geneva, Switzerland, <http://www.iso.org>.

⁵ Available from Aerospace Industries Association of America, Inc., 1250 Eye St. NW, Washington, DC, 20005.

⁶ The boldface numbers in parentheses refer to a list of references at the end of this standard.

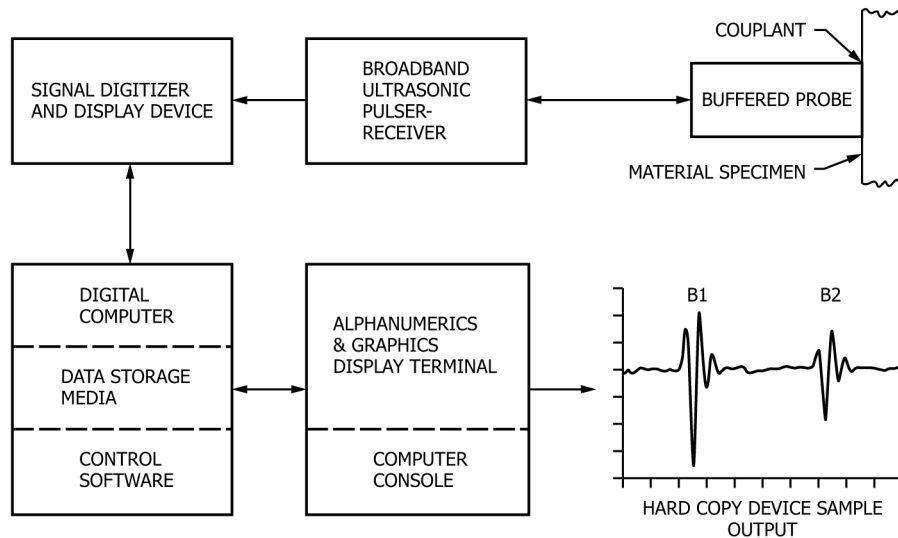

FIG. 2 Block Diagram of Computer System for Ultrasonic Signal Acquisition and Processing for Pulse-Echo Attenuation Measurement

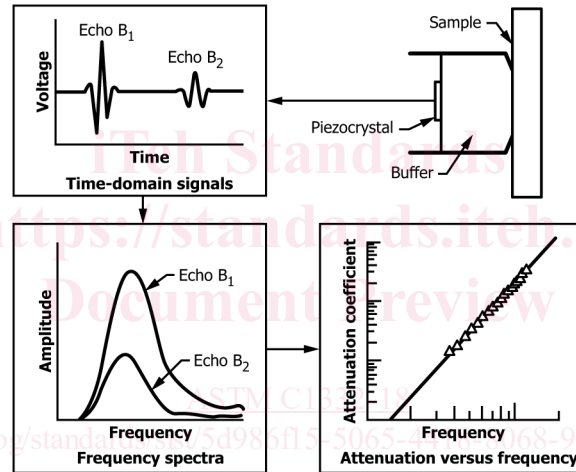

FIG. 3 Schematic of Signal Acquisition and Data-Processing Stages for Determining Frequency Dependence of Attenuation Coefficient by Using Broadband Ultrasonic Pulse-Echo Method

3.1.9 *free surface*—the back surface of a solid test sample interfaced with a very low density medium, usually air or other gas, to assure that the back surface reflection coefficient equals 1 to a high degree of precision.

3.1.10 *frequency (f)*—number of oscillations per second of ultrasonic waves, measured in megahertz, MHz, herein.

3.1.11 *front surface*—the surface of a test sample to which the buffer rod is coupled at normal incidence (designated as test surface in Terminology E1316).

3.1.12 *inherent attenuation*—ultrasound energy loss in a solid as a result of scattering, diffusion, and absorption. This standard assumes that the dominant inherent losses are due to Rayleigh and stochastic scattering (2) by the material microstructure, for example, by grains, grain boundaries, and micropores. Measured ultrasound energy loss which, if not corrected, may include losses due to diffraction, individual macroflaws, surface roughness, couplant variations, and transducer defects.

3.1.13 *reflection coefficient (R)*—measure of relative intensity of sound waves reflected back into a material at an interface, defined in terms of the acoustic impedance of the material in which the sound wave originates (Z_0) and the acoustic impedance of the material interfaced with it (Z_i), where $R = [(Z_i - Z_0)/(Z_i + Z_0)]^2$.

3.1.14 *test sample*—a solid coupon or material part that meets the constraints needed to make the attenuation coefficient measurements described herein, that is, a test sample or part having flat, parallel, smooth, preferably ground/polished opposing (front and back) surfaces and having no discrete flaws or anomalies that are unrepresentative of the inherent properties of the material.

3.1.15 *transmission coefficient (T)*—measure of relative intensity of sound waves transmitted through an interface, defined in terms of the acoustic impedance of the material in which the sound wave originates (Z_0) and the acoustic impedance of the material interfaced with it (Z_i), where $T = (4Z_i Z_0)/(Z_i + Z_0)^2$ so that $R + T = 1$.

3.1.16 *wavelength (λ)*—distance that sound (of a particular frequency) travels during one period (during one oscillation), $\lambda = v/f$, where v is the velocity of sound in the material and where velocity is measured in cm/ μ s, and wavelength in cm, herein.

3.2 Other terms used in this test method practice are defined in Terminology [E1316](#).

4. Summary of Test Method

~~4.1 This test method describes a procedure for determining a material's inherent attenuation coefficient and attenuation spectrum by means of a buffered broadband probe operating in the pulse-echo contact mode on a solid sample that has smooth, flat, parallel surfaces.~~

~~4.2 The procedure described in this test method involves digital acquisition and computer processing of ultrasonic echo waveforms returned by the test sample. Test sample constraints, probing methods, data validity criteria, and measurement corrections are prescribed herein.~~

4. Summary of Practice

4.1 This practice describes a procedure for determining a material's inherent attenuation coefficient and attenuation spectrum by means of a buffered broadband probe operating in the pulse-echo contact mode on a solid sample that has smooth, flat, parallel surfaces.

4.2 The procedure described in this practice involves digital acquisition and computer processing of ultrasonic echo waveforms returned by the test sample. Test sample constraints, probing methods, data validity criteria, and measurement corrections are prescribed herein.

5. Significance and Use

5.1 This test method practice is useful for characterizing material microstructure or measuring variations in microstructure that occur because of material processing conditions and thermal, mechanical, or chemical exposure (3). When applied to monolithic or composite ceramics, the procedure should reveal microstructural gradients due to density, porosity, and grain variations. This test method practice may also be applied to polycrystalline metals to assess variations in grain size, porosity, and multiphase constituents.

5.2 This test method practice is useful for measuring and comparing microstructural variations among different samples of the same material or for sensing and measuring subtle microstructural variations within a given sample.

5.3 This test method practice is useful for mapping variations in the attenuation coefficient and the attenuation spectrum as they pertain to variations in the microstructure and associated properties of monolithic ceramics, ceramic composites and metals.

5.4 This test method practice is useful for establishing a reference database for comparing materials and for calibrating ultrasonic attenuation measurement equipment.

5.5 This test method practice is not recommended for highly attenuating monolithics or composites that are thick, highly porous, or that have rough or highly textured surfaces. For these materials Practice [E664E664/E664M](#) may be appropriate. Guide [E1495E1495/E1495M](#) is recommended for assessing attenuation differences among composite plates and laminates that may exhibit, for example, pervasive matrix porosity or matrix crazing in addition to having complex fiber architectures or thermomechanical degradation (3). The proposed ASTM Standard Test Method Practice for Measuring Ultrasonic Velocity in Advanced Ceramics (C1331) is recommended for characterizing monolithic ceramics with significant porosity or porosity variations (4).

6. Personnel Qualifications

~~6.1 It is recommended that nondestructive evaluation/examination personnel applying this test method~~If specified in the contractual agreement, personnel performing examinations to this practice shall be qualified in accordance with a nationally or internationally recognized NDT personnel qualification practice or standard such as ASNT SNT-TC-1A, MIL STD 410, ANSI/ASNT CP-189, SNT-TC-1A, NAS 410, ISO 9712, or a similar document. The qualification document and certified by the employer or certifying agency, as applicable. The practice or standard used and its applicable revision(s) should~~revision shall be specified~~identified in a contractual agreement between the using parties.

6.2 Knowledge of the principles of ultrasonic testing is required. Personnel applying this test method practice shall be experienced practitioners of ultrasonic examinations and associated methods for signal acquisition, processing, and interpretation.

6.3 Personnel shall have proficiency in computer programming and signal processing using digital methods for time and frequency domain signal analysis. Familiarity with the Fourier transform and associated spectrum analysis methods for ultrasonic signals is required.

7. Qualification of Nondestructive Agencies

7.1 If specified in the contractual agreement, NDT agencies shall be qualified and evaluated as described in Specification E543. The applicable edition of Specification E543 shall be specified in the contractual agreement.

8. Apparatus

8.1 The instrumentation and apparatus for pulse-echo contact ultrasonic attenuation coefficient measurement should include the following (see Fig. 2). Appropriate equipment can be assembled from any of several suppliers.

8.1.1 *Buffered Probe*, meeting the following requirements:

8.1.1.1 The probe should have a center frequency that corresponds to an ultrasonic wavelength that is less than one fifth of the thickness, d , of the test sample.

8.1.1.2 The probe bandwidth should match the bandwidth of received echoes. This may require transducer bandwidths of from 50 to 200 MHz.

8.1.1.3 The probe should be well constructed, carefully selected, and shown to be free of internal defects and structural anomalies that distort received echoes.

8.1.1.4 The frequency spectra of the first two echoes returned by the free end of the buffer should be essentially gaussian (bell shaped).

8.1.2 *Buffer Rod*, with length that results in a time delay ≥ 3 times the interval between two successive echoes from the back surface of the test sample. This imposes a limit on the test sample thickness if the buffer rod length is fixed or predetermined by design.

8.1.3 *Couplant*, meeting the following requirements:

8.1.3.1 The couplant should be a fluid such as glycerine or an ultrasonic gel that will not corrode, damage, or be absorbed by the test sample or part being examined.

8.1.3.2 The couplant film or couplant layer thickness should be much less than the ultrasound wavelength in the couplant at the probe's center frequency.

8.1.3.3 Ideally, to avoid echo distortions, the acoustic impedance of the couplant should be between that of the buffer rod material and test sample (5). With fluid couplants, just reducing the couplant layer thickness is usually more practical than impedance matching by changing the fluid. For example, if glycerine is used between a fused quartz buffer and a steel sample, the couplant layer thickness should be less than 1 μm .

8.1.3.4 Dry coupling, for example, with an elastomer or thin deformable polymer film, may be used provided that echo distortions or phase inversions are avoided by acoustic impedance matching (5) and by substantially reducing the couplant layer thickness.

8.1.4 *Pulser-Receiver*, having a bandwidth exceeding that of the probe by a factor of 1.5 to 2 and including the probe/transducer bandwidth to avoid significant distortions of the received signals. The pulser-receiver should have controls for pulse voltage level, pulse duration, pulse repetition rate, pulse damping, gain (signal amplification steps), and received signal and synchronization outputs to an oscilloscope.

8.1.4.1 The pulse voltage should be ≈ 200 to ≈ 250 V.

8.1.4.2 The pulse duration should be between 10 to 20 ns to produce the necessary broadband excitation pulses having center frequencies of 50 MHz or greater.

8.1.4.3 The pulse repetition rate should be set slow enough to avoid overlapped echoes but fast enough to allow the averaging of 16 to 32 transient signals for digitizing each echo waveform.

8.1.5 *Coaxial Cable*, connecting the probe and pulser-receiver. The cable should be electrically impedance matched to both the probe and pulser-receiver to avoid electronic reverberations and consequent signal distortions. Short cables, 1 m or less, should be used.

8.1.6 *Oscilloscope Voltage Amplifier*, preferably a programmable vertical amplifier module using a general purpose interface bus (such as the IEEE 488 GPIB) and having selectable gains, for example, 20, 40, and 60 dB.

8.1.7 *Oscilloscope Time Base*, preferably a programmable time base module using a general purpose interface bus (GPIB) with a resolution of at least 5 ns and selectable ranges including a fundamental time base of 200 ns.

8.1.8 *Digital Time Synthesizer*, bus programmable module, to introduce a known time delay between the start of three separate time gates in the oscilloscope time base. Each time gate must generate a "window" to exclusively contain one of the echoes of interest, that is, front surface and two successive back surface echoes. The gate, that is, window start times, should be program controlled and program readable.

8.1.9 *Waveform Digitizing Oscilloscope*, bus programmable to window and digitize individual time domain ultrasonic echo waveforms into a 512-element array (or 1024-element array) with a data sampling interval of 1.95 ns (or 0.97 ns).

8.1.10 *Video Monitors*, one analog, one digital (optional) for real-time visual inspection of echo waveforms and for making interactive manual adjustments to the data acquisition controls. These control adjustments may include probe realignment/repositioning, couplant thickness optimization, and other adjustments to obtain echo waveforms that meet acceptance criteria given herein.

8.1.11 *XYZ-Axis Micropositioner*, motorized and bus programmable for holding the test sample support and positioning sample and coupling it to the probe buffer rod with a preset loading force.

8.1.12 *Load Cell and Controller*, bus programmable for measuring and controlling the force with which the buffer rod is coupled to the test sample so that the couplant thickness can be minimized and coupling force between sample and probe can be optimized.

8.1.13 *Probe Fixture*, to firmly attach the probe to the load cell.

8.1.14 *Sample Support*, to firmly hold test sample as it is brought in contact with and coupled to probe buffer rod at normal incidence.

8.1.15 *Computer and Instrument Interface*, to provide programmable bus control, data acquisition, data storage, data processing, graphics display, and output to a printer.

8.1.16 *Control Software*, to start and control the interface bus; optimize signal digitization and digitizer intensity; set the voltage scaling on the digitizer; control and set the time synthesizer; control and set the micropositioner and coupling pressure; monitor the load cell; etc.

8.1.17 *Signal Processing Software*, including FFT (fast Fourier transform) to acquire, process, and store waveform data; calculate and display attenuation coefficients and attenuation spectra; etc.

8.2 Some of the previously mentioned apparatus may be omitted in favor of manual alignment and coupling of test samples to the probe. For example, a manual precision laboratory jack may be used instead of the motorized XYZ-axis micropositioner. The load cell may also be omitted in this case. The programmable digital time synthesizer may be omitted by manually setting the time interval among windows containing front and back surface echoes.

8.3 For monolithic ceramics and polycrystalline metals, the frequency range of the pulser-receiver, probe-transducer should be between 10 and 200 MHz. The specific frequency range needed depends on the nature of the material and specimen thickness. For most metallic samples with thicknesses between 3 and 5 mm, a frequency range from 10 to 100 MHz will suffice while for most ceramic samples with similar thicknesses a frequency range from 20 to 200 MHz may be required for defining an attenuation spectrum.

8.4 In commercially available probes (search units) the buffer rod material is usually fused silica (and in rare cases quartz). Fused silica is appropriate because it is amorphous and transmits ultrasound well. When a fused silica buffer is coupled to metallic samples, the buffer/sample interface will have a sufficiently high reflection coefficient, R , to assure strong back surface echoes. The reflection coefficient is significantly less when a fused silica buffer is coupled to a ceramic (such as silicon carbide or silicon nitride). Therefore, ultrasound reflections within the sample will be weaker and result in weak back surface echoes returned to the transducer. This may be a problem because pulse-echo attenuation measurements depend on strong back surface echoes. This problem can be remedied by constructing probes with alternative buffer materials that optimize buffer/sample interface reflections. Ideally, the reflection coefficient R should have values between 0.6 and 0.8 for the buffer-sample interface.

9. Procedure

9.1 *Preparatory Steps to Assure Optimum Coupling and Signal Acquisition.*

9.1.1 Clean the face of the buffer rod with ethanol or similar mild cleaning fluid to remove any dust, dirt, or residual couplant.

9.1.2 Place a small drop of fluid couplant on the buffer rod and then place the sample against the buffer. Whether the couplant consists of a fluid, elastomer, or plastic film, make sure that it completely wets or adheres to the buffer and sample surfaces.

9.1.3 Support the test sample with a hard, dry backing material, preferably with a rough-machined or sawtooth surface profile. Avoid coupling the sample to the backing material. The back surface directly opposite the probe should be free, that is, essentially air-backed.

9.1.4 Apply pressure until two back surface echoes appear on the video monitor. The optimum force for a 1.2 cm (0.5 in.) diameter buffer rod coupled to a test sample with glycerine couplant will be 44 to 88 N (10 to 20 lb) or a pressure of 220 to 440 KPa (30 to 60 psi).

9.1.5 Minimize losses and signal reverberations within the couplant layer by reducing the couplant thickness to $1/2$ μm .

9.2 The pulse-echo configuration and echo system for attenuation measurements is illustrated in Fig. 3.

9.2.1 Adjust the pulser-receiver (for example, pulser energy/damping and receiver gain/bandpass) to optimize the echo waveforms displayed by the video monitors.

9.2.2 Before digitizing echo waveforms, study the front and back surface echoes returned by the test sample. The magnitude (amplitude) spectra of their Fourier transforms should be essentially gaussian.

9.2.3 Collect the following echoes:

9.2.3.1 Echo F_0 from the free end of the buffer rod before it is coupled to the test sample.

9.2.3.2 Front surface echo F from the end of the buffer rod after it is coupled to the test sample.

9.2.3.3 Back surface echoes B_1 and B_2 from within the sample.

9.2.4 Using the digitizing oscilloscope (A/D device), individually window, digitize, average, and save the time-domain echo waveforms F_0 , F , B_1 and B_2 . Repeat and average the measurements at several arbitrary positions on the test sample.

9.2.4.1 Using the time synthesizer (A/D delay device), determine and save the time delays for starting the individual windows containing echo waveforms F_0 , F , B_1 and B_2 to acquire the waveforms under program control sequentially.