



Designation: **F2193–14** **F2193 – 18**

Standard Specifications and Test Methods for Components Used in the Surgical Fixation of the Spinal Skeletal System¹

This standard is issued under the fixed designation F2193; the number immediately following the designation indicates the year of original adoption or, in the case of revision, the year of last revision. A number in parentheses indicates the year of last reappraisal. A superscript epsilon (ϵ) indicates an editorial change since the last revision or reappraisal.

1. Scope

1.1 These specifications and test methods are intended to provide a comprehensive reference for the components of systems used in the surgical fixation of the spinal skeletal system. The document catalogs standard specifications that specify material, labeling, and handling requirements. The specifications and test methods also establish common terminology that can be used to describe the size and other physical characteristics of spinal components and performance definitions related to the performance of spinal components. Additionally, the specifications and test methods establish performance requirements and standard test methods to consistently measure performance-related mechanical characteristics of spinal components.

1.2 These specifications and test methods are part of a series of standards addressing systems used in the surgical fixation of the spinal skeletal system. These specifications and test methods concentrate on the individual components, which are found in many spinal fixation systems. If the user is interested in evaluating the next level in the spinal fixation system chain, the interconnections between individual components and subassemblies (two or more components), the user should consult Guide **F1798**. At the highest level in this chain is Test Methods **F1717**, which is used to evaluate an entire construct assembled from many components and involves numerous interconnections and several subassemblies.

1.3 It is not the intention of these specifications and test methods to define levels of performance or case-specific clinical performance for spinal components addressed by this document. Insufficient knowledge to predict the consequences of using any of these components in individual patients for specific activities of daily living is available. Furthermore, it is not the intention of this document to describe or specify specific designs for the individual components of systems used in the surgical internal fixation of the spinal skeletal system.

1.4 These specifications and test methods may not be appropriate for all types of spinal surgical fixation systems. The user is cautioned to consider the appropriateness of this document in view of the particular implant system and its potential application.

1.5 This document includes the following specifications and test methods that are used in determining the spinal component's mechanical performance characteristics:

1.5.1 Specification for Metallic Spinal Screws—**Annex A1**.

1.5.2 Specification for Metallic Spinal Plates—**Annex A2**.

1.5.3 Specification for Metallic Spinal Rods—**Annex A3**.

1.5.4 Test Method for Measuring the Static and Fatigue Bending Strength of Metallic Spinal Screws—**Annex A4**.

1.6 Unless otherwise indicated, the values stated in SI units shall be regarded as the standard.

1.7 This standard may involve hazardous materials, operations, and equipment. *This standard does not purport to address all of the safety concerns, if any, associated with its use. It is the responsibility of the user of this standard to establish appropriate safety, health, and environmental practices and determine the applicability of regulatory limitations prior to use.*

1.8 *This international standard was developed in accordance with internationally recognized principles on standardization established in the Decision on Principles for the Development of International Standards, Guides and Recommendations issued by the World Trade Organization Technical Barriers to Trade (TBT) Committee.*

¹ These specifications and test methods are under the jurisdiction of ASTM Committee **F04** on Medical and Surgical Materials and Devices and are the direct responsibility of Subcommittee **F04.25** on Spinal Devices.

Current edition approved Oct. 1, 2014; Feb. 1, 2018. Published November 2014; March 2018. Originally approved in 2002. Last previous edition approved in 2007 as **F2193–02** (2007); **F2193 – 14**. DOI: 10.1520/F2193-14; 10.1520/F2193-18.

2. Referenced Documents

2.1 ASTM Standards: General²

- E4 Practices for Force Verification of Testing Machines
- E6 Terminology Relating to Methods of Mechanical Testing
- E122 Practice for Calculating Sample Size to Estimate, With Specified Precision, the Average for a Characteristic of a Lot or Process
- E467 Practice for Verification of Constant Amplitude Dynamic Forces in an Axial Fatigue Testing System
- E1823 Terminology Relating to Fatigue and Fracture Testing
- E1942 Guide for Evaluating Data Acquisition Systems Used in Cyclic Fatigue and Fracture Mechanics Testing
- F382 Specification and Test Method for Metallic Bone Plates
- F543 Specification and Test Methods for Metallic Medical Bone Screws
- F565 Practice for Care and Handling of Orthopedic Implants and Instruments
- F983 Practice for Permanent Marking of Orthopaedic Implant Components
- F1582 Terminology Relating to Spinal Implants
- F1717 Test Methods for Spinal Implant Constructs in a Vertebrectomy Model
- F1798 Test Method for Evaluating the Static and Fatigue Properties of Interconnection Mechanisms and Subassemblies Used in Spinal Arthrodesis Implants
- F1839 Specification for Rigid Polyurethane Foam for Use as a Standard Material for Testing Orthopaedic Devices and Instruments
- F2503 Practice for Marking Medical Devices and Other Items for Safety in the Magnetic Resonance Environment
- F2943 Guide for Presentation of End User Labeling Information for Musculoskeletal Implants

2.2 ASTM Standards: Materials²

- D4020 Specification for Ultra-High-Molecular-Weight Polyethylene Molding and Extrusion Materials
- F67 Specification for Unalloyed Titanium, for Surgical Implant Applications (UNS R50250, UNS R50400, UNS R50550, UNS R50700)
- F136 Specification for Wrought Titanium-6Aluminum-4Vanadium ELI (Extra Low Interstitial) Alloy for Surgical Implant Applications (UNS R56401)
- F138 Specification for Wrought 18Chromium-14Nickel-2.5Molybdenum Stainless Steel Bar and Wire for Surgical Implants (UNS S31673)
- F648 Specification for Ultra-High-Molecular-Weight Polyethylene Powder and Fabricated Form for Surgical Implants
- F1295 Specification for Wrought Titanium-6Aluminum-7Niobium Alloy for Surgical Implant Applications (UNS R56700)
- F1314 Specification for Wrought Nitrogen Strengthened 22 Chromium–13 Nickel–5 Manganese–2.5 Molybdenum Stainless Steel Alloy Bar and Wire for Surgical Implants (UNS S20910)
- F1472 Specification for Wrought Titanium-6Aluminum-4Vanadium Alloy for Surgical Implant Applications (UNS R56400)

2.3 ISO Standards:

- ISO 14630 Non-active Surgical Implants—General Requirements³

3. Terminology

3.1 Unless otherwise defined in these specifications and test methods, the terminology used in this document that is related to spinal implants will be in accordance with the definitions of Specification F382, Specification F543, and Terminology F1582.

3.2 Unless otherwise defined in these specifications and test methods, the terminology related to mechanical testing that is used in this document will be in accordance with the definitions of Terminology E6, Terminology E1823, Specification F382, Terminology F1582, Test Methods F1717, and Guide F1798.

3.3 Terminology—General:

3.3.1 *expansion head screw*, *n*—threaded anchor that is designed so that the head can be elastically deformed, through mechanical means, to establish an interconnection with another spinal construct element.

3.3.2 *locking screw*, *n*—threaded anchor that is rigidly connected to the longitudinal element of the spinal construct.

3.3.3 *self-locking screw*, *n*—threaded anchor design that undergoes a deformation process at the end of the insertion process which results in the screw’s locking to the mating spinal construct element.

3.3.4 *shaft screw*, *n*—threaded anchor having an unthreaded shank equal to its thread diameter.

3.4 Terminology—Geometric:

3.4.1 *rod diameter (mm)*, *n*—length in mm of a chord passing through the center of the rod’s cross-section.

² For referenced ASTM standards, visit the ASTM website, www.astm.org, or contact ASTM Customer Service at service@astm.org. For *Annual Book of ASTM Standards* volume information, refer to the standard’s Document Summary page on the ASTM website.

³ Available from International Organization for Standardization (ISO), 1 rue de Varembe, Case postale 56, CH-1211, Geneva 20, Switzerland.

3.4.2 *rod length (mm), n*—overall dimension measured in mm between the ends of a given rod.

3.5 *Terminology—Mechanical/Structural:*

3.5.1 *0.2 % offset displacement (mm), n*—permanent displacement equal to 0.002 times the test gage section length for the specific test, in mm. The test gage section length is equal to the bending moment arm for spinal screw tests. The test gage section length is equal to the center span distance for spinal plate and rod tests where the loading rollers are directly contacting the test specimen (Fig. A2.1 and Fig. A3.1). The test gage section length is equal to the unsupported distance between the ends of the extension segments for spinal plate and rod tests where extension segments are used to load the test sample (Fig. A2.2). (distance *OB* in Fig. A4.1).

3.5.2 *axial pull-out load (N), n*—tensile force in N required to fail or remove a screw from a material into which the screw has been inserted when tested in accordance with Specification and Test Methods F543, Annex A3.

3.5.3 *bending fatigue runout moment (N·m), n*—value in N·m of the maximum moment that can be applied to a spinal component where all of the tested samples have experienced 2 500 000 loading cycles without a failure at a specific *R*-ratio.

3.5.4 *bending moment arm, L (mm), n*—distance in mm between the point where the test sample is gripped (typically the axis of the longitudinal element) and the line-of-action for the applied force prior to any deformation of the assembly. (See dimension *L* of Fig. A4.2).

3.5.5 *bending stiffness, S (N/mm), n*—slope in N/mm of the initial linear elastic portion of the load versus total displacement curve (slope of line *Om* in Fig. A4.1).

3.5.6 *bending ultimate moment (N·m), n*—maximum bending moment in N·m that can be applied to a test sample. This would correspond to the bending moment at Point *E* in Fig. A4.1.

3.5.7 *bending yield moment (N·m), n*—bending moment in N·m necessary to produce a 0.2 % offset displacement in the spinal component. If the specimen fractures before the test reaches the 0.2 % offset displacement point, the bending yield moment shall be defined as the bending moment at fracture (point *D* in Fig. A4.1).

3.5.8 *exposed length (mm), n*—linear distance measured in mm between the surface of the test block that the screw is embedded in during the test and the location where the screw is anchored (typically the axis of the longitudinal element) in the test fixture (see Fig. A4.2).

3.5.9 *gross failure, n*—permanent displacement resulting from fracture or plastic deformation in excess of the yield displacement that renders the spinal component ineffective in fulfilling its intended function.

3.5.10 *insertion depth (mm), n*—linear advancement in mm of the screw into the test block measured relative to its seated position at the test block's surface prior to testing.

3.5.11 *median bending fatigue moment at N cycles (N·m), n*—value in N·m of the maximum moment that can be applied to a spinal component for which 50 % of the test specimens of a given sample can be expected to survive *N* loading cycles at a specific *R*-ratio.

3.5.12 *permanent displacement (mm), n*—total displacement in mm remaining after the applied load has been removed from the test specimen.

3.5.13 *torsion yield moment (N·m), n*—applied torque in N·m at which the screw reaches its proportional limit when tested in accordance with Specification and Test Methods F543, Annex A1. The value is determined by using an offset method with a 2° angular offset.

3.5.14 *total displacement (mm), n*—distance in mm, in the direction of the applied load, which the load application point has moved relative to the zero load intercept of the initial linear segment of the load versus displacement curve (point *O* in Fig. A4.1).

3.5.15 *yield displacement (mm), n*—total displacement in mm associated with the bending yield strength (distance *OA* in Fig. A4.1).

4. Significance and Use

4.1 Spinal implant constructs are typically a compilation of several components. Screws, plates, and rods are integral components of many spinal implant constructs. These components are designed to transfer load between the bone and the longitudinal or transverse element, or both. These specifications and test methods identify specifications for such components and define standard equivalent test methods that can be used when evaluating different related component designs.

4.2 Since the loading of spinal components *in-vivo* may differ from the loading configurations addressed in these specifications and test methods, the results obtained from this document may not predict *in-vivo* performance of either the components or the construct as a whole. Such tests can, however, be used to compare different component designs in terms of relevant mechanical performance characteristics.

4.3 The performance-related mechanical characteristics determined by these specifications and test methods will supply the user with information that may be used to predict the mechanical performance of different design variations of similar (function and indication) spinal construct components.

5. Requirements

5.1 The following spinal components shall conform to the requirements of the listed standard specification:

5.1.1 *Screws*—Standard Specification for Metallic Spinal Screws (see [Annex A1](#)).

5.1.2 *Plates*—Standard Specification for Metallic Spinal Plates (see [Annex A2](#)).

5.1.3 *Rods*—Standard Specification for Metallic Spinal Rods (see [Annex A3](#)).

6. Marking, Packaging, Labeling, and Handling

6.1 Mark spinal components using the methods specified in Practice [F983](#).

6.2 Markings on spinal components shall identify the manufacturer or distributor. When size permits, the following information should be legibly marked on the spinal component (items listed in order of preference):

6.2.1 Manufacturer's name or logo,

6.2.2 Material and, when applicable, the ASTM designation,

6.2.3 Catalog number,

6.2.4 Manufacturing lot number, and

6.2.5 If the component is manufactured according to an ASTM specification, the ASTM designation.

6.3 Packaging shall be adequate to protect the spinal component during shipment.

6.4 Package labeling for spinal components shall include the following information:

6.4.1 Manufacturer and product name,

6.4.2 Catalog number,

6.4.3 Lot or serial number,

6.4.4 Material and, when applicable, the ASTM designation for the material, and

6.4.5 The sterility condition of the packaged spinal component.

6.5 Package labeling may elect to follow guidance in Guide [F2943](#) for package label presentation.

6.6 Product labeling may include marking for safety in the Magnetic Resonance Environment in accordance with Practice [F2503](#).

6.7 Spinal components shall be cared for and handled according to the requirements specified in Practice [F565](#).

7. Materials

7.1 The manufacturer is responsible for ensuring that materials used to manufacture spinal components are suitable for implanting into the body. Material suitability can be verified with the methods described in ISO 14630.

7.2 The manufacturer should also consider the materials of other spinal components within the spinal implant construct when selecting a material. Avoid the mixing of materials within a spinal implant construct in order to prevent the development of undesirable corrosion conditions.

7.3 All spinal components that are made of materials that have an ASTM standard designation shall meet those requirements given in the ASTM standards. The following is a list of some materials that have been used for spinal components:

7.3.1 Unalloyed Titanium (see Specification [F67](#)).

7.3.2 Wrought Titanium–6Aluminum–4Vanadium ELI (Extra Low Interstitial) Alloy (see Specification [F136](#)).

7.3.3 Stainless Steel Bar and Wire (see Specification [F138](#)).

7.3.4 Wrought Titanium–6Aluminum–7Niobium Alloy (see Specification [F1295](#)).

7.3.5 Wrought Nitrogen Strengthened – 22Chromium–12.5Nickel–5Manganese–2.5Molybdenum Stainless Steel Bar and Wire (see Specification [F1314](#)).

7.3.6 Wrought Titanium Ti-6Al-4V Alloy (see Specification [F1472](#)).

8. Keywords

8.1 bend testing–plate; bend testing–rod; bend testing–screw; bend testing–surgical implants; fatigue test–plate; fatigue test–rod; fatigue test–screw; fatigue test–surgical implants; orthopedic medical device–plate; orthopedic medical device–rod; orthopedic medical device–screw; orthopedic spinal devices; performance; spinal arthrodesis; surgical devices; terminology; test methods–surgical implants

ANNEXES**(Mandatory Information)****A1. SPECIFICATION FOR METALLIC SPINAL SCREWS****A1.1 Scope**

A1.1.1 This specification describes metallic spinal screws that are used as anchor elements in spinal arthrodesis implants for the surgical fixation of the skeletal spinal system.

A1.2 Classification

A1.2.1 Classify spinal screws according to the classification methods identified in Specification **F543**.

A1.2.2 Spinal screws can also be classified with regard to the screw's interconnecting capabilities with other spinal fixation system components such as expansion head, locking, and self-locking.

A1.3 Marking, Packaging, Labeling, and Handling

A1.3.1 Dimensions of spinal screws shall follow the nomenclature established in Section **3**.

A1.3.2 In addition to the requirements of Section **6**, add the screw diameter on the spinal screw labeling (when size permits).

A1.3.3 In addition to the packaging information contained in Section **6**, include the screw diameter and screw length.

A1.4 Materials

A1.4.1 Select spinal screw materials in accordance with the requirements and recommendations of Section **7**.

A1.5 General Requirements, Performance Considerations, and Test Methods

A1.5.1 *Drive Connection*—Suggested drive recesses for spinal screws can be found in Specification **F543**, Annex A6.

A1.5.2 *Torsion Properties*—Determine the screw's torsion strength characteristics (torsional yield moment, maximum torque, and breaking angle) using the test method of Specification **F543**, Annex A1.

A1.5.3 *Driving Torque Requirements*—Determine the driving torque requirements (insertion and removal torque) for self-tapping and self-drilling spinal screws according to the test method found in Specification **F543**, Annex A2 with the following conditional requirements:

A1.5.3.1 Manufacture the test blocks from Grade ~~40~~20, Specification **F1839** rigid polyurethane foam whose length is no less than the insertion depth of the test being conducted.

A1.5.3.2 Conduct the driving torque tests at a motor speed of 30 r/min.

A1.5.3.3 *Specific Screw Performance Tests*—Measure the driving torque of the longest length spinal screw of a given design until the insertion depth is equal to the screw's thread length.

A1.5.3.4 *Comparative Screw Performance Tests*—Measure the driving torque until an insertion depth is reached that is equal to the shortest maximum screw thread length possible for the screw designs being compared.

A1.5.4 *Axial Pull-Out Load*—Determine the screw’s axial pull-out load using the standard test method of Specification **F543**, Annex A3 with the following conditional requirements:

A1.5.4.1 Manufacture the test blocks from Grade 20, Specification **F1839** rigid polyurethane foam.

A1.5.4.2 Insert each screw into the test block at a motor speed of 30 r/min.

A1.5.4.3 *Specific Screw Performance Tests*—Insert the shortest spinal screw of a given design until the insertion depth is equal to the screw’s thread length.

A1.5.4.4 *Comparative Screw Performance Tests*—Insert each spinal screw until an insertion depth is reached that is equal to the shortest maximum screw thread length possible for the screw designs being compared.

A1.5.5 *Bending Properties*—Determine the screw’s bending structural stiffness, bending yield moment, bending ultimate moment, bending fatigue runout moment, and when applicable, the median fatigue bending moment at 2 500 000 cycles using the test methods described in **Annex A4**.

A2. SPECIFICATION FOR METALLIC SPINAL PLATES

A2.1 Scope

A2.1.1 This specification describes metallic spinal plates that are used as longitudinal elements in spinal arthrodesis implants for the surgical fixation of the skeletal spinal system.

A2.2 Classification

A2.2.1 Plates intended for spinal applications can be classified with regard to the following characteristics:

<https://standards.iteh.ai/catalog/standards/sist/d7571a9d-f434-4e1e-99f0-99582bf6c5aa/astm-f2193-18>

A2.2.2 *Preferred Anatomic Location*—The spinal region where the plate is indicated (such as cervical, thoracic, lumbar, and sacral) and position (anterior versus posterior).

A2.2.3 *Preferred Use Limited to Specific Procedures*—The type of surgical procedure where the plate is indicated (such as reconstruction, trauma, deformity, degenerative).

A2.3 Marking, Packaging, Labeling, and Handling

A2.3.1 Dimensions of bone plates shall follow the nomenclature established in Section **3**.

A2.3.2 In addition to the requirements of Section **6**, include the plate length on spinal plate labeling.

A2.4 Materials

A2.4.1 Select spinal plate materials in accordance with the requirements and recommendations of Section **7**.

A2.5 Performance Considerations and Test Methods

A2.5.1 Determine the spinal plate’s bending structural stiffness, bending yield moment, bending ultimate moment, bending fatigue

runout moment, and, when applicable, the median bending fatigue moment at 2 500 000 cycles using the methods of Specification **F382** and in accordance with the following requirements.

A2.5.2 Configure the four-point bending test fixtures so that the loading rollers (inner rollers that are located dimension “a” apart) are positioned in accordance with the requirements of **Table A2.1** (see also **Fig. A2.1**).

A2.5.3 Position the test fixture support rollers (outer rollers that are located dimension “h” from the nearest loading roller) far enough away from the loading rollers so that the test article is free to respond to the applied bending moment (see **Fig. A2.1**). Under ideal conditions, position the support rollers in accordance with the recommended dimensions of **Table A2.1**. The dimension “h” may be reduced to $a/2$ in order to accommodate testing of shorter plates, but this condition must be documented in the final report.

A2.5.4 Maintain the test fixture configuration consistent for comparative tests.

A2.5.5 Only unused and untested specimens shall be included in the sample for a given spinal plate design. Include only final form and finished components in the sample.

Static Tests

A2.5.6 The sample size used for static tests shall be determined according to the methods defined in Practice **E122** for any given loading condition. If insufficient information is available to determine a suitable sample size with Practice **E122**, use a minimum sample size of five.

A2.5.7 Load the test specimen during static tests at a displacement rate not to exceed 10 mm/min.

Fatigue Tests

A2.5.8 Test at least two specimens at each of three different maximum moment levels. One of the three maximum moment levels shall satisfy the maximum runout moment condition. Several references have been compiled that can provide the user with guidance and recommendations for selecting suitable sample sizes for fatigue studies used to develop an *M-N* diagram. **(1 and 2)**⁴

A2.5.9 Conduct the recommended fatigue test in a laboratory air environment at room temperature. Other test environments (simulated body fluid, 9-g NaCl per 1000 mL water saline, a saline drip, or water) may be used while testing, but the suitability of using the respective test environment must be justified, given the accelerated nature of the laboratory fatigue test. If an alternative test environment is used, record all pertinent parameters related to the environmental conditions (temperature, pH, solution strengths, and so forth) before, during, and after the test.

A2.5.10 Apply sinusoidal cyclic loads in load control at an *R* ratio of 0.10 for testing of devices intended for either the lumbar and thoracic spine regions. Apply sinusoidal cyclic loads in load control at an *R* ratio of -1.0 for testing of devices intended for the cervical spine region. **Fig. A2.2** illustrates a test setup for spinal plates that is capable of applying fully reversed loads (*R* = -1). Other *R* ratios may be used but must be documented in the report.

A2.5.11 The user shall determine the frequency at which to conduct the fatigue test, but the maximum frequency of cyclic loading shall be 30 Hz.

TABLE A2.1

Spinal Location	h (mm)	a (mm)
Cervical	35.00	35.00
Thoracic and Lumbar	76.00	76.00

⁴ The boldface numbers in parentheses refer to the list of references at the end of this standard.

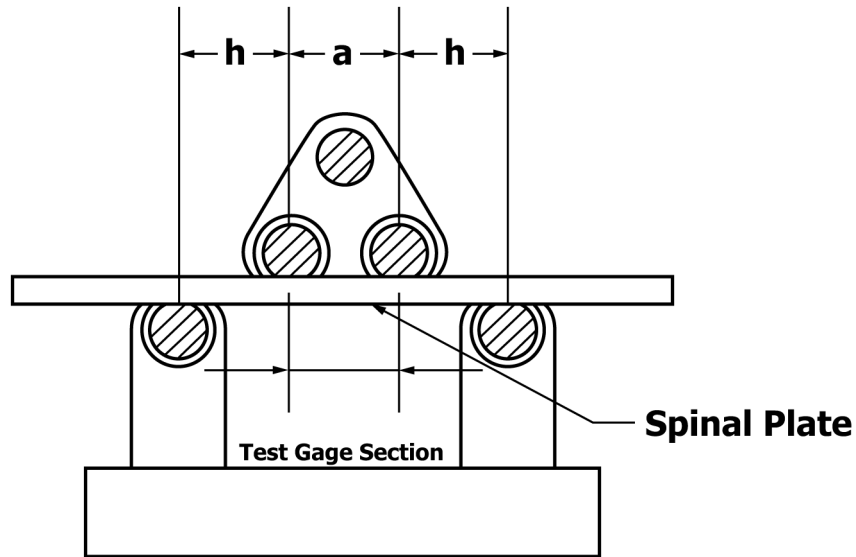

FIG. A2.1 Spinal Plate Test Configuration

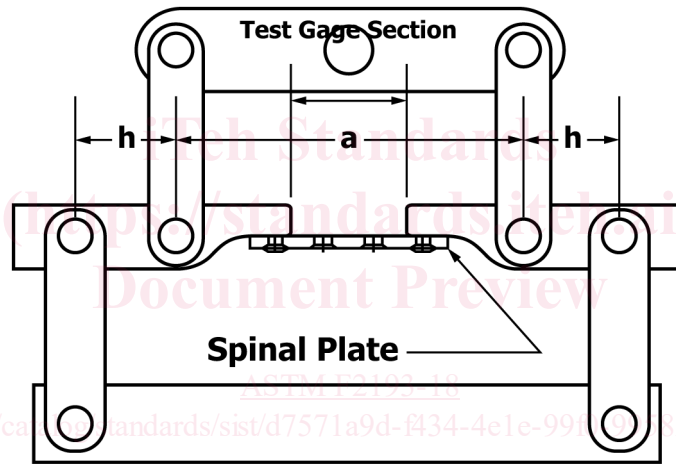

FIG. A2.2 Spinal Plate Test Configuration, $R = -1$ Loading

A2.5.12 Initial fatigue maximum moment levels that are 75, 50, and 25 % of the bending ultimate moment determined with the static test method are suggested for the fatigue study. One maximum moment level should have specimens that do not fail before 2 500 000 cycles. The difference between the maximum moment value resulting in specimen failure and the maximum runout moment value must be less than 10 % of the device's bending ultimate moment.

A3. SPECIFICATION FOR METALLIC SPINAL RODS

A3.1 Scope

A3.1.1 This specification describes spinal rods that are used as longitudinal elements in spinal arthrodesis implants for the surgical fixation of the skeletal spinal system.

A3.2 Classification

A3.2.1 Spinal rods indicated for spinal applications can be classified with regard to the following characteristics:

A3.2.2 *Preferred Anatomic Location*—The spinal region where the rod is indicated (such as cervical, thoracic, lumbar, and sacral) and position (anterior versus posterior).

A3.2.3 *Preferred Use Limited to Specific Procedures*—The type of surgical procedure where the rod is indicated (such as reconstruction, trauma, deformity, degenerative).

A3.3 Marking, Packaging, Labeling, and Handling

A3.3.1 Dimensions of spinal rods shall follow the nomenclature established in Section 3.

A3.3.2 In addition to the requirements of Section 6, include the rod diameter and rod length on spinal rod labeling.

A3.4 Materials

A3.4.1 Select spinal rod materials in accordance with the requirements and recommendations of Section 7.

A3.5 Performance Considerations and Test Methods

A3.5.1 Determine the spinal rod’s bending structural stiffness, bending yield moment, bending ultimate moment, bending fatigue runout moment, and when applicable, the median bending fatigue moment at 2 500 000 cycles using the methods of Specification F382 and in accordance with the following requirements.

A3.5.2 Fit the test fixture with 90° “V” alignment notched rollers. This roller profile will allow the testing of a range of rod sizes with a single roller set. Such rollers will also prevent the application of the load at the most highly stressed point on the circumference of the rod.

A3.5.3 Configure the four-point bending test fixtures so that the loading rollers (inner rollers that are located dimension “a” apart) are positioned in accordance with the requirements of Table A2.1 (see also Fig. A3.1).

<https://standards.iteh.ai/catalog/standards/sist/d7571a9d-f434-4e1e-99f0-99582bf6c5aa/astm-f2193-18>

A3.5.4 Position the test fixture support rollers (outer rollers that are located dimension “h” from the nearest loading roller) in accordance with the recommended dimensions of Table A2.1.

A3.5.5 Maintain the test fixture configuration consistent for comparative tests.

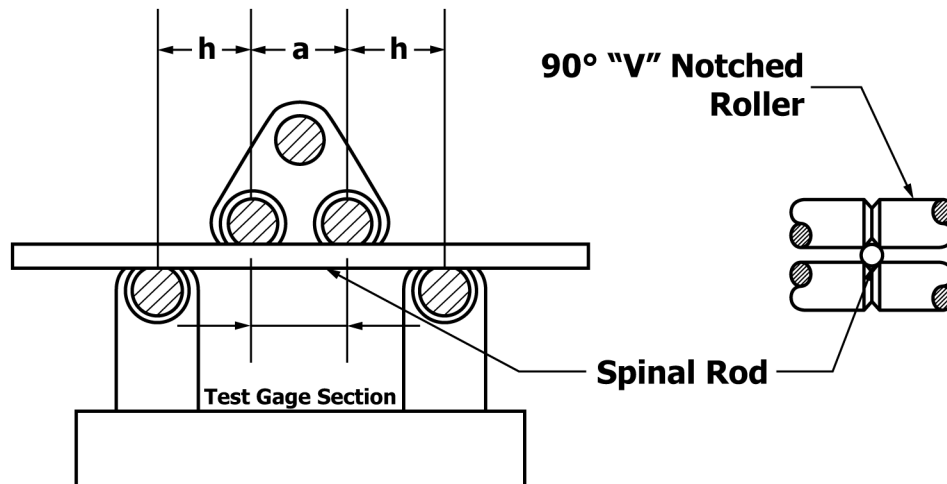

FIG. A3.1 Spinal Rod Test Configuration

A3.5.6 Only unused and untested specimens shall be included in the sample for a given spinal plate design. Include only final form and finished components in the sample.

Static Test Method

A3.5.7 The sample size used for static tests shall be determined according to the methods defined in Practice E122 for any given loading condition. If insufficient information is available to determine a suitable sample size with Practice E122, use a minimum sample size of five.

A3.5.8 Load the test specimen during static tests at a displacement rate not exceeding 10 mm/min.

Fatigue Test Method

A3.5.9 For fatigue studies, test at least two specimens at each of three different maximum moment levels. One of the three maximum moment levels shall satisfy the maximum runout moment condition. Several references have been compiled that can provide the user with guidance and recommendations for selecting suitable sample sizes for fatigue studies used to develop an *M-N* diagram. **(1 and 2)**

A3.5.10 Conduct the recommended fatigue test in a laboratory air environment at room temperature. Other test environments (simulated body fluid, 9-g NaCl per 1000 mL water saline, a saline drip, or water) may be used while testing, but the suitability of using the respective test environment must be justified, given the accelerated nature of the laboratory fatigue test. If an alternative test environment is used, record all pertinent parameters related to the environmental conditions (temperature, pH, solution strengths, and so forth) before, during, and after the test.

A3.5.11 Apply sinusoidal cyclic loads in load control at an *R* ratio of 0.10 for testing of devices intended for either the lumbar and thoracic spine regions. Apply sinusoidal cyclic loads in load control at an *R* ratio of -1.0 for testing of devices intended for the cervical spine region. Fig. A2.2 illustrates a test setup for spinal plates that can be similarly adapted in order to apply fully reversed loads (*R* = -1) to spinal rods. Other *R* ratios may be used but must be documented in the report.

A3.5.12 The user shall determine the frequency at which to conduct the fatigue test, but the maximum recommended frequency of cyclic loading shall be 30 Hz.

A3.5.13 Initial fatigue maximum moment levels that are 75, 50, and 25 % of the bending ultimate moment determined with the static test method are suggested for the fatigue study. One maximum moment level should have specimens that do not fail before 2 500 000 cycles. The difference between the maximum moment value resulting in specimen failure and the maximum runout moment value must be less than 10 % of the device's bending ultimate moment.

A4. TEST METHOD FOR MEASURING THE STATIC AND FATIGUE BENDING STRENGTH OF METALLIC SPINAL SCREWS

A4.1 Scope

A4.1.1 This test method describes the methods for determining the static and dynamic bending properties of metallic spinal screws that are used in spinal arthrodesis implants.

A4.1.2 This test method is intended to provide a means of mechanically characterizing different component designs of spinal screws. It is not the intention of this test method to define levels of performance of spinal screws since insufficient information is available to predict the consequences of the use of a particular screw design.