



Designation: B820 – 18

Standard Test Method for Bend Test for Determining the Formability of Copper and Copper Alloy Strip¹

This standard is issued under the fixed designation B820; the number immediately following the designation indicates the year of original adoption or, in the case of revision, the year of last revision. A number in parentheses indicates the year of last reapproval. A superscript epsilon (ϵ) indicates an editorial change since the last revision or reapproval.

1. Scope*

1.1 This test method describes the technique of bend testing copper and copper alloy strip samples to determine product formability or the ability to resist cracking when forming a bend around a specific radius. The criterion for failure is the occurrence of cracks on the outer (convex) radius of curvature.

1.2 This bend test is limited to strip from 0.003 to and including 0.031 in. (0.076 to and including 0.79 mm) thick.

1.3 The forming or punch radius for the bend test is to be determined by agreement between the producer and the customer.

1.4 *Units*—Values stated in inch-pound units are to be regarded as standard. The values given in parentheses are mathematical conversions to SI units which are provided for information only and are not considered standard.

1.5 *This standard does not purport to address all of the safety concerns, if any, associated with its use. It is the responsibility of the user of this standard to establish appropriate safety, health, and environmental practices and determine the applicability of regulatory limitations prior to use.*

1.6 *This international standard was developed in accordance with internationally recognized principles on standardization established in the Decision on Principles for the Development of International Standards, Guides and Recommendations issued by the World Trade Organization Technical Barriers to Trade (TBT) Committee.*

2. Referenced Documents

2.1 *ASTM Standards:*²

[B846 Terminology for Copper and Copper Alloys](#)

[E6 Terminology Relating to Methods of Mechanical Testing](#)

¹ This test method is under the jurisdiction of ASTM Committee B05 on Copper and Copper Alloys and is the direct responsibility of Subcommittee B05.06 on Methods of Test.

Current edition approved March 1, 2018. Published March 2018. Originally approved in 1992. Last previous edition approved in 2014 as B820 – 14a. DOI: 10.1520/B0820-18.

² For referenced ASTM standards, visit the ASTM website, www.astm.org, or contact ASTM Customer Service at service@astm.org. For *Annual Book of ASTM Standards* volume information, refer to the standard's Document Summary page on the ASTM website.

[E290 Test Methods for Bend Testing of Material for Ductility](#)

3. Terminology

3.1 For definitions of terms related to copper and copper alloys, refer to Terminology [B846](#).

3.2 For definitions of terms related to mechanical testing, refer to Terminology [E6](#).

3.3 *Definitions of Terms Specific to This Standard:*

3.3.1 *bend, longitudinal (or good way bend)*—a bend with an axis perpendicular to the direction of rolling, drawing, or extrusion (see [Fig. 1](#)).

3.3.2 *bend, transverse (or bad way bend)*—a bend with an axis on a plane parallel to the direction of rolling, drawing, or extrusion (see [Fig. 1](#)).

NOTE 1—The usage of these two terms is consistent with Test Methods [E290](#).

4. Summary of Test Method

4.1 The bend test is made by applying a force transversely to the length of the specimen in the portion being bent, usually at mid-length. The 90° bending forces are applied through an arrangement illustrated in [Fig. 2](#), while 180° bending forces are applied through an arrangement illustrated in [Fig. 3](#). When complete fracture does not occur, the convex surface of the specimen is examined for cracks. In general, the test using a 180° bend angle is a more severe test than the test using a 90° bend angle.

5. Significance and Use

5.1 This bend test provides information as to the formability or the ability of copper and copper alloy strip to resist cracking when being formed.

5.2 This test method can be used as a quality control tool to determine if material will form to a given radius.

5.3 This test method is also useful in research and development to provide data for use in selecting a spring material that will safely form to the geometry of a given part.

5.4 The results are suitable for direct application in design and manufacturing, only when all factors such as the geometry

*A Summary of Changes section appears at the end of this standard

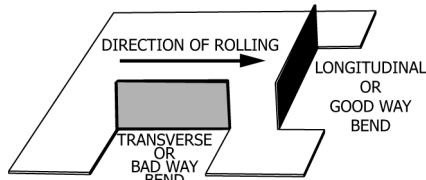

FIG. 1 Direction of Bending

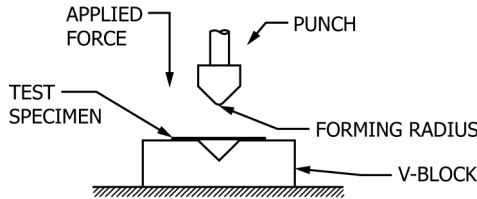

FIG. 2 V-Block and Punch for 90° Bend Test

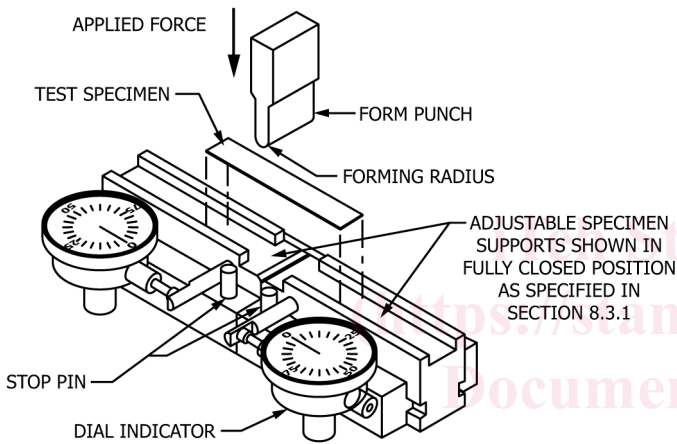

FIG. 3 Fixture for 180° Bend Test

of the part, punch and die design, lubrication, stamping speed, and other material properties are known.

6. Apparatus

6.1 Various devices are suitable for 90° or 180° bend testing. The apparatus shall provide these features:

6.1.1 90° Bend Test Fixture—An illustration of this test fixture is shown in Fig. 2. A specimen rests on a pair of pins, rollers, or radiused flat supports; a pin, mandrel, or 90° V-block punch of a given bend radius for applying the bending force directly at the mid-length.

6.1.2 180° Bend Test Fixture—An illustration of this test fixture is shown in Fig. 3. A specimen rests on a pair of pins, rollers, or radiused flat supports; a pin, mandrel, or 180° punch of a given bend radius for applying the bending force directly at the mid-length. Dial indicators with a precision of 0.0005 in. (0.013 mm) or better are necessary to accurately position the two supports.

6.1.2.1 To prevent breaking the punch, it is recommended not to use a radius smaller than 1/2 the thickness of the material being tested.

6.2 The radius of the single pin, mandrel, or punch applying the bend force at the mid-length shall differ not more than ±5 % from the nominal value of the radius.

6.3 The length of all pins, rolls, mandrels, and radius flats must exceed the width of the specimen; they must be strong enough and sufficiently rigid to resist significant deformation.

7. Test Specimens

7.1 Test Specimen Requirement:

7.1.1 When the purchaser does not define a bending width requirement, the default width shall be 1/2 ± 1/16 in. (12.7 ± 1.57 mm).

7.1.1.1 Four test specimens shall be required, two in the longitudinal and two in the transverse directions for the 90° and 180° test angles.

7.1.2 When the purchaser defines a bending test at or below 1/4 in. (6.35 mm), then the producer can optionally apply the narrow width specimen as defined in 7.1.2.1 (see Fig. 4).

7.1.2.1 The narrow width specimen consists of four beams: 0.024 ± 0.002 in. (0.6 ± 0.05 mm), 0.047 ± 0.003 in. (1.2 ± 0.08 mm), 0.095 ± 0.004 in. (2.4 ± 0.1 mm), and 0.189 ± 0.005 in. (4.8 ± 0.13 mm). Four test specimens shall be required, two in the longitudinal and two in the transverse directions, for the 90° and 180° angles.

7.1.2.2 When the purchaser does not identify a specific width in the narrow width specimen, the default width shall be 0.095 ± 0.004 in. (2.4 ± 0.1 mm).

7.2 The test specimens may be prepared by cutting, shearing, or stamping.

7.3 The test specimens shall have any convenient length greater than 1/2 in. (12.7 mm) unless specified otherwise by the purchaser.

7.4 Direction of Specimen:

7.4.1 The bending characteristics of a metal vary with the orientation of the bends to the direction of rolling. A longitudinal bend will typically take a sharper bend radius than a transverse bend. This characteristic becomes more pronounced as the metal thickness increases.

7.4.2 In a longitudinal specimen, its length shall be parallel to the direction of rolling as indicated in Fig. 1.

7.4.3 In a transverse bend specimen, its length shall be perpendicular to the direction of rolling as indicated in Fig. 1.

7.4.4 Unless stated otherwise, the length and width of rectangular specimens shall be in the plane of the two major dimensions of the product.

7.5 The specimen thickness shall be measured using a micrometer with a precision of 0.0001 in. (0.00254 mm).

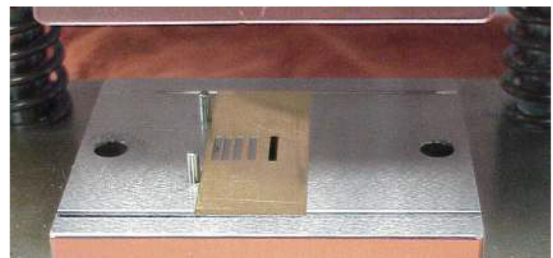

FIG. 4 Narrow Width Specimen – Produced by Stamping