



Designation: D3353 – 18

# Standard Test Methods for Fibrous-Insulated Magnet Wire<sup>1</sup>

This standard is issued under the fixed designation D3353; the number immediately following the designation indicates the year of original adoption or, in the case of revision, the year of last revision. A number in parentheses indicates the year of last reapproval. A superscript epsilon ( $\epsilon$ ) indicates an editorial change since the last revision or reapproval.

## 1. Scope\*

1.1 These test methods cover the testing of fibrous-insulated electrical conductors, commonly referred to as magnet wire, which are used in electrical apparatus. The test methods are intended primarily for evaluation of the electrical insulating materials used. It is intended that these test methods be used, except where modified by individual specifications for particular applications.

1.1.1 These test methods apply to those magnet wires that are fiber-covered and in which the substrate is bare conductor or is coated with an underlying insulating film as covered by Test Methods D1676. Fiber-covered wires are produced by serving helically or wrapping fibers or fibrous-tape insulation uniformly around the wire in single and multiple layers. The served or wrapped materials are bonded or not bonded to the underlying wire.

1.2 The test methods appear in the following sections:

Procedure	Section
Measurement of Dimensions	7
Electrical Resistance of Conductors	5
Elongation	4
Adhesion and Flexibility	8
Fibrous Coverage	6
Dielectric Breakdown Voltage	9

1.3 This standard and IEC 60851 are similar if not equivalent in technical content.

1.4 This standard and NEMA MW 1000 are similar if not equivalent in technical content.

1.5 The values stated in inch-pound units are to be regarded as standard. The values given in parentheses are mathematical conversions to SI units that are provided for information only and are not considered standard.

1.6 *This standard does not purport to address all of the safety concerns, if any, associated with its use. It is the responsibility of the user of this standard to establish appropriate safety, health, and environmental practices and deter-*

<sup>1</sup> These test methods are under the jurisdiction of ASTM Committee D09 on Electrical and Electronic Insulating Materials and are the direct responsibility of Subcommittee D09.12 on Electrical Tests.

Current edition approved March 15, 2018. Published March 2018. Originally approved in 1974. Last previous edition approved in 2010 as D3353 – 10. DOI: 10.1520/D3353-18.

*mine the applicability of regulatory limitations prior to use. See 8.4.1 and 9.4.1 for specific caution statements.*

*1.7 This international standard was developed in accordance with internationally recognized principles on standardization established in the Decision on Principles for the Development of International Standards, Guides and Recommendations issued by the World Trade Organization Technical Barriers to Trade (TBT) Committee.*

## 2. Referenced Documents

2.1 *ASTM Standards:*<sup>2</sup>

B193 Test Method for Resistivity of Electrical Conductor Materials

D149 Test Method for Dielectric Breakdown Voltage and Dielectric Strength of Solid Electrical Insulating Materials at Commercial Power Frequencies

D1676 Test Methods for Film-Insulated Magnet Wire

D1711 Terminology Relating to Electrical Insulation

D5423 Specification for Forced-Convection Laboratory Ovens for Evaluation of Electrical Insulation

E8 Test Methods for Tension Testing of Metallic Materials

2.2 *Other Standards:*

IEC 60851 Methods of Test for Winding Wires<sup>3</sup>

NEMA Standards Publication No. MW 1000 on Magnet Wire<sup>4</sup>

## 3. Terminology

3.1 *Definitions:*

3.1.1 For definitions of terms used in this test method, refer to Terminology D1711.

3.1.2 *Definition of Term(s) Specific to this Standard:*

3.1.2.1 *serving*—a uniform wrapping of fibrous insulation around a magnet wire of bare conductor.

3.1.2.2 *fibrous coverage, of served-magnet wire*—that characteristic which allows a fibrous served magnet wire to be

<sup>2</sup> For referenced ASTM standards, visit the ASTM website, www.astm.org, or contact ASTM Customer Service at service@astm.org. For *Annual Book of ASTM Standards* volume information, refer to the standard's Document Summary page on the ASTM website.

<sup>3</sup> Available from International Engineering Consortium, 549 West Randolph Street, Suite 600, Chicago IL 60661-2208.

<sup>4</sup> Available from National Electrical Manufacturers Association (NEMA), 1300 N. 17th St., Suite 1752, Rosslyn, VA 22209, http://www.nema.org.

\*A Summary of Changes section appears at the end of this standard

wound around mandrels in a prescribed manner without causing observable openings in the fibrous coverage.

#### 4. Elongation

4.1 *Scope*—This test method covers the determination of the elongation of fibrous insulated magnet wire that results in a fracture of the conductor.

4.2 *Significance and Use*—The elongation determined by this test method provides a general measure of the ductility of the conductor and the effect of the processing to which it has been subjected during the insulating operation.

4.3 *Apparatus*—The equipment shall have a minimum separation sufficient to attach and measure the length of the test specimen between grips, and be capable of elongating the specimen to its breaking point, at a constant rate. The equipment shall be such that the error of the length measurement will be 1 % or less. Suitable, non-slip grips are required that will not damage the specimen in the region of elongation. Drum or capstan type grips have been found to be unsatisfactory.

NOTE 1—See Test Methods E8 for a discussion of machines, gripping devices, and rates of stressing.

##### 4.4 Procedure:

4.4.1 Remove the fibrous insulation without distorting the conductor for wire sizes 0.0253 in. (0.6426 mm) (AWG 22) and finer. Do not remove the fibrous insulation from sizes larger than 0.0253 in. (0.6426 mm) (AWG 22).

4.4.2 *Standard Method*: Insert the test specimen into the grips resulting in an original length of  $10 \pm 0.1$  in. ( $254 \pm 2.5$  mm) to be stretched. Elongate the wire at a constant rate of  $12 \pm 1$  in./min ( $305 \pm 25$  mm/min) until the conductor breaks. Determine the length at break by measuring the final distance between the grips. Discard the results for any specimens that break within  $\frac{1}{4}$  in. (6 mm) of the grips. When breaks occur frequently in this manner, a need for modification of the equipment or technique is indicated.

4.4.3 *Bench Mark Method*: Rectangular, square, or round wire larger than 0.0651 in. (1.654 mm) in diameter is allowed to be tested using bench marks. Measure the original length between bench marks to ensure the distance between the bench marks is  $10 \pm 0.1$  in. ( $254 \pm 2.5$  mm). Insert the wire specimen into the grips and locate the bench marks centrally and not more than  $\frac{1}{2}$  in. (12.7 mm) from either grip. Elongate the wire specimen at a constant rate of  $12 \pm 1$  in./min ( $305 \pm 25$  mm/min) until the conductor breaks. Match the broken ends of the specimen, place together, and measure the final length to the nearest 0.1 in. at break between the bench marks. In order to minimize the effect of local variations in the wire under test, test three specimens of the sample. Discard the results for any specimens that break within  $\frac{1}{4}$  in. (6 mm) of the grips or the bench marks. When breaks occur frequently in this manner, a need for modification of the equipment or technique is indicated.

4.5 *Calculation*—Calculate the elongation as follows:

$$\text{Elongation, \%} = [(A - B)/B] \times 100 \quad (1)$$

where:

A = length at break, and

B = original length

##### 4.6 Report the Following Information:

- 4.6.1 Bare conductor dimensions,
- 4.6.2 Bare conductor material,
- 4.6.3 Type and build of film insulation,
- 4.6.4 Type of fibrous-insulation,
- 4.6.5 Number of servings,
- 4.6.6 Direction of servings,
- 4.6.7 Type of varnish,
- 4.6.8 Whether or not bench marks are used, and
- 4.6.9 Individual and average elongation.

##### 4.7 Precision and Bias:

4.7.1 This test method has been in use for many years, but no statement of precision has been made and no activity is planned to develop such a statement.

4.7.2 No information is presented on the bias of this procedure in Section 4, for measuring the percent elongation, as no material having an accepted reference value is available.

### 5. Electrical Resistance of Conductors

5.1 *Scope*—This test method covers the determination of the electrical resistance of fibrous insulated magnet wire conductors.

5.2 *Significance and Use*—Accurate control of resistance is necessary to meet apparatus design parameters. Resistance is expressed in terms of ohms per unit length corrected to 20°C (68°F) and is a function of conductor dimensions, resistivity, and temperature. Resistance is affected by the processing operation.

5.3 *Apparatus*—The types of apparatus utilized for measuring resistance and length are specified in Test Method B193.

5.4 *Procedure*—Remove the insulation on both ends of the test specimen for electrical contact. The cleaning operation must not affect the conductor dimensions. Determine the electrical resistance of the test specimen.

NOTE 2—While balancing the bridge, care must be taken to prevent excessive heating of the specimen as a result of prolonged current, and to avoid changes in temperature due to air drafts or to variations in ambient conditions.

##### 5.5 Report the Following Information:

- 5.5.1 Bare conductor dimensions,
- 5.5.2 Bare conductor material,
- 5.5.3 Type and build of film insulation,
- 5.5.4 Type of fibrous-insulation,
- 5.5.5 Number of servings,
- 5.5.6 Direction of servings,
- 5.5.7 Type of varnish,
- 5.5.8 Test temperature,
- 5.5.9 Specimen length,
- 5.5.10 Apparatus used,
- 5.5.11 Resistance reading, and
- 5.5.12 Resistance ohms per unit length corrected to 20°C (68°F).

##### 5.6 Precision and Bias:

5.6.1 This test method has been in use for many years, but no statement of precision has been made and no activity is planned to develop such a statement.

5.6.2 No information is presented on the bias of this procedure in Section 5, for measuring the electrical resistance of the conductor, as no material having an accepted reference value is available.

## 6. Fibrous Coverage

6.1 *Scope*—This test method covers the determination of the quality of fibrous servings on round magnet wire or bare conductor.

6.2 *Significance and Use*—The results of this test are indicative of the quality of the fibrous servings applied to the wire. High quality serving is required since it will permit the wire to be stressed by bending without exposing the conductor or underlying film.

### 6.3 Apparatus:

6.3.1 Means for chucking and rotating mandrels while maintaining suitable wire tension.

6.3.2 *Mandrels*, to be specified.

### 6.4 Procedure:

6.4.1 Wind the wire, with only sufficient tension to form it around a mandrel of a diameter to be specified, without twisting or stretching and at a speed not to exceed 40 rpm. Ten turns closely spaced along the mandrel shall constitute a test specimen.

NOTE 3—Commercially, it is normally specified that the bare conductor or underlying film is not exposed when the specimen is wound around a mandrel having a diameter ten times the diameter of the bare conductor.

6.4.2 Examine the test specimen for exposed bare conductor or underlying film with normal vision.

### 6.5 Report the Following Information:

6.5.1 Bare conductor dimensions,

6.5.2 Bare conductor material,

6.5.3 Type and build of film insulation,

6.5.4 Type of fibrous-insulation,

6.5.5 Number of servings,

6.5.6 Direction of servings, and

6.5.7 List the smallest mandrel diameter that does not expose the bare conductor or underlying film.

### 6.6 Precision and Bias:

6.6.1 No information is presented about either the precision or bias of Section 6 for evaluating fibrous coverage since the test result is nonquantitative.

## 7. Measurement of Dimensions

### 7.1 Scope:

7.1.1 These test methods determine the dimensions of the bare or film insulated conductor and the fibrous-insulated magnet wire.

7.1.1.1 The micrometer technique is applicable to wires where compressibility of the conductor or insulation is not a factor.

7.1.1.2 The tapered mandrel technique is suitable for measuring the diameter of wires where compressibility is a factor

as in stranded or litz wire, or where the insulating material is readily distorted as in the case of some organic fibers.

7.2 *Significance and Use*—Knowledge of the dimensions of the bare conductor, overall dimensions of fibrous-insulated magnet wire, and average insulation addition to the dimensions are necessary for specification and use purposes. Bare conductor dimensions are one of the basic parameters used in the design of electrical machinery and the breakdown voltage is related to the thickness of the insulation.

### 7.3 Apparatus:

7.3.1 *Micrometer*, apparatus for measuring the dimensions of bare conductor and fibrous-insulated wire shall consist of accurate hand or bench micrometers. The micrometer spindle loading shall not be greater than 8 oz<sup>1</sup>/<sub>4</sub>-in. diameter anvil (225 g/6.36-mm diameter anvil) for 0.0651 in. (1.654 mm) (AWG 14) and finer. For all round wire sizes larger than 0.0651 in. (1.654 mm) and for all rectangular and square wire sizes, the micrometer spindle loading shall be 3 lb ± 1 oz<sup>1</sup>/<sub>4</sub>-in. diameter anvil (1360 ± 28 g/6.36-mm diameter anvil).

NOTE 4—Other instruments such as electronic micrometers or light wave micrometers have been found suitable for measuring the bare or film insulated conductor diameter.

NOTE 5—Spindle pressures specified above have been established based on experience with copper.

7.3.2 *Mandrel*, tapered (Fig. 1).

7.3.3 *Weights*, suitable (Table 1).

7.3.4 *Calipers*, precision, with vernier reading to 0.001 in. (0.025 mm).

### 7.4 Specimens:

7.4.1 When using the micrometer technique, the test specimens shall consist of at least 3 in. (76 mm) straight lengths of wire free of kinks or obvious defects. Carefully remove the specimens from the spool or container at 1 ft (0.3 m) intervals without more than 1 % stretch for straightening.

7.4.2 When measuring the diameter using the tapered mandrel technique, the specimen shall be of sufficient length to wind a minimum of 25 turns on the tapered mandrel and shall be free of kinks or other obvious defects. Carefully remove the specimens from the spool to avoid damaging or stretching.

### 7.5 Procedure:

7.5.1 For round wire, using a micrometer, measure the overall diameter at four places approximately 45° apart around the specimen. The average of the high and low values is considered the overall specimen diameter.

7.5.2 For round wire, using the tapered mandrel technique, attach one end of the specimen to the small end of the mandrel, pass the wire over a pulley as indicated in Fig. 2 and attach the free end of the wire to the load specified in Table 1. Closely wind a minimum of 25 turns onto the tapered mandrel at the rate of approximately 12 rpm. Measure the length of the winding along the mandrel with a vernier caliper and divide this distance by the number of turns along the mandrel. The quotient is the average overall diameter of the wire.

7.5.3 For rectangular wire, measure the overall thickness and width for each of three specimens. On square wire, mark one side to insure that the measurement will be taken on the same sides on both the insulated wire and bare conductor. The

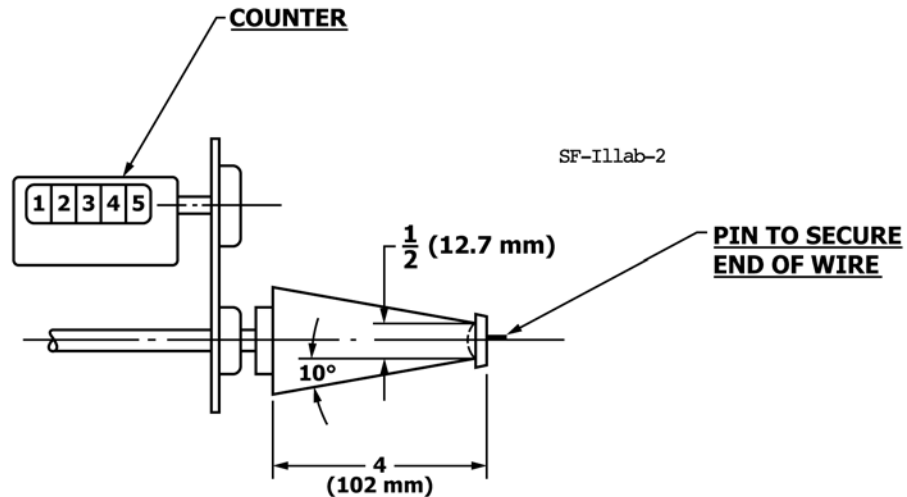

FIG. 1 Tapered Mandrel

TABLE 1 Copper Wire Tension<sup>A</sup>

AWG Size	Nominal Bare Diameter		Tension to Produce 7500 psi (52 MPa)	
	in.	mm	lb	kg
22	0.0253	0.6426	3.8	1.75
23	0.0226	0.5740	3.0	1.50
24	0.0201	0.5105	2.4	1.10
25	0.0179	0.4547	1.9	0.85
26	0.0159	0.4039	1.5	0.70
27	0.0142	0.3607	1.2	0.55
28	0.0126	0.3200	<sup>B</sup>	0.45
29	0.0113	0.2870	<sup>B</sup>	0.35
30	0.0100	0.2540	<sup>B</sup>	0.27

<sup>A</sup>Wire tensions for materials other than copper have not been established.

<sup>B</sup>For weights less than 1 lb (0.45 kg) use specified kilogram values.

average of the three thicknesses and width measurements shall be the overall thickness or width, or both.

7.5.4 Remove the fibrous insulation without distorting the conductor and measure the diameter or thickness and width as in 7.5.1 or 7.5.3. In the case of stranded or litz wire it is desirable to measure the conductor diameter as described in 7.5.2.

7.5.5 When an insulating film underlies the fibrous insulation, remove it by chemical means without distorting the conductor and measure the diameter or thickness and width as in 7.5.1 or 7.5.3.

NOTE 6—If there is a question of a chemical stripper removing some of the bare conductor, immerse a piece of the bare conductor of known dimensions in the stripper for the same length of time, remove, wash off, dry and remeasure. If a measurable amount of bare conductor is removed, a different stripper must be used or a correction applied. An alternative method of removing enameled film from copper is to subject the sample to a flame followed by immediate immersion in a low-boiling alcohol such as methyl or ethyl alcohol or mixtures of these and water.

7.5.6 For round wire with an underlying film, subtract the minimum allowable diameter of the film-insulated magnet wire from the average overall diameter. Report this as the increase in diameter due to fibrous insulation.

7.5.7 For rectangular and square wire with an underlying film, subtract the minimum allowable increase in dimensions of the film-insulated magnet wire from the average overall dimensions. Report these as the increase in dimensions due to fibrous insulation.

7.6 Report the Following Information:

- 7.6.1 Individual bare conductor dimensions,
- 7.6.2 Bare conductor material,
- 7.6.3 Number of strands for litz wire,
- 7.6.4 Type and build of film insulation(s),
- 7.6.5 Type of fibrous-insulation,
- 7.6.6 Number of servings,
- 7.6.7 Direction of servings,
- 7.6.8 Type of varnish,
- 7.6.9 Average dimensions of fibrous-insulated wire,
- 7.6.10 Minimum allowable increase in dimensions of film insulation,
- 7.6.11 Average dimensions of bare conductor,
- 7.6.12 Minimum and maximum overall dimensions, and
- 7.6.13 Average increase in dimensions due to fibrous-insulation.

7.7 Precision and Bias:

7.7.1 This test method has been in use for many years, but no statement of precision has been made and no activity is planned to develop such a statement.

7.7.2 No information is presented on the bias of this procedure in Section 7, for measuring the dimensions of fibrous magnet wire, as no material having an accepted reference value is available.