



Designation: E910 – 18

# Standard Test Method for Application and Analysis of Helium Accumulation Fluence Monitors for Reactor Vessel Surveillance<sup>1</sup>

This standard is issued under the fixed designation E910; the number immediately following the designation indicates the year of original adoption or, in the case of revision, the year of last revision. A number in parentheses indicates the year of last reapproval. A superscript epsilon ( $\epsilon$ ) indicates an editorial change since the last revision or reapproval.

## 1. Scope

1.1 This test method describes the concept and use of helium accumulation for neutron fluence dosimetry for reactor vessel surveillance. Although this test method is directed toward applications in vessel surveillance, the concepts and techniques are equally applicable to the general field of neutron dosimetry. The various applications of this test method for reactor vessel surveillance are as follows:

1.1.1 Helium accumulation fluence monitor (HAFM) capsules,

1.1.2 Unencapsulated, or cadmium or gadolinium covered, radiometric monitors (RM) and HAFM wires for helium analysis,

1.1.3 Charpy test block samples for helium accumulation, and

1.1.4 Reactor vessel (RV) wall samples for helium accumulation.

1.2 *This standard does not purport to address all of the safety concerns, if any, associated with its use. It is the responsibility of the user of this standard to establish appropriate safety, health, and environmental practices and determine the applicability of regulatory limitations prior to use.*

1.3 *This international standard was developed in accordance with internationally recognized principles on standardization established in the Decision on Principles for the Development of International Standards, Guides and Recommendations issued by the World Trade Organization Technical Barriers to Trade (TBT) Committee.*

## 2. Referenced Documents

2.1 *ASTM Standards:*<sup>2</sup>

**C859** Terminology Relating to Nuclear Materials

**E170** Terminology Relating to Radiation Measurements and Dosimetry

**E261** Practice for Determining Neutron Fluence, Fluence Rate, and Spectra by Radioactivation Techniques

**E482** Guide for Application of Neutron Transport Methods for Reactor Vessel Surveillance

**E706** Master Matrix for Light-Water Reactor Pressure Vessel Surveillance Standards

**E844** Guide for Sensor Set Design and Irradiation for Reactor Surveillance

**E853** Practice for Analysis and Interpretation of Light-Water Reactor Surveillance Results

**E854** Test Method for Application and Analysis of Solid State Track Recorder (SSTR) Monitors for Reactor Surveillance

**E900** Guide for Predicting Radiation-Induced Transition Temperature Shift in Reactor Vessel Materials

**E944** Guide for Application of Neutron Spectrum Adjustment Methods in Reactor Surveillance

**E1005** Test Method for Application and Analysis of Radiometric Monitors for Reactor Vessel Surveillance

**E1018** Guide for Application of ASTM Evaluated Cross Section Data File

**E2005** Guide for Benchmark Testing of Reactor Dosimetry in Standard and Reference Neutron Fields

## 3. Terminology

3.1 *Definitions*—For definition of terms used in this test method, refer to Terminologies **C859** and **E170**. For terms not defined therein, reference may be made to other published glossaries.<sup>3</sup>

## 4. Summary of the HAFM Test Method

4.1 Helium accumulation fluence monitors (HAFMs) are passive neutron dosimeters that have a measured reaction product that is helium. The monitors are placed in the reactor locations of interest, and the helium generated through (n, $\alpha$ ) reactions accumulates and is retained in the HAFM (or HAFM capsule) until the time of removal, perhaps many years later.

<sup>3</sup> See *Dictionary of Scientific Terms*, 3rd Edition, Sybil P. Parker, Ed., McGraw Hill, Inc.

<sup>1</sup> This test method is under the jurisdiction of ASTM Committee E10 on Nuclear Technology and Applications and is the direct responsibility of Subcommittee E10.05 on Nuclear Radiation Metrology.

Current edition approved Feb. 1, 2018. Published March 2018. Originally approved in 1982. Last previous edition approved in 2013 as E910 – 07 (2013). DOI: 10.1520/E0910-18.

<sup>2</sup> For referenced ASTM standards, visit the ASTM website, www.astm.org, or contact ASTM Customer Service at service@astm.org. For *Annual Book of ASTM Standards* volume information, refer to the standard's Document Summary page on the ASTM website.

The helium is then measured very precisely by high-sensitivity gas mass spectrometry (1, 2).<sup>4</sup> The neutron fluence is then directly obtained by dividing the measured helium concentration by the spectrum-averaged cross section. Competing helium producing reactions, such as  $(\gamma, \alpha)$  do not, except for  ${}^9\text{Be}(\gamma, \alpha)$ , affect the HAFM results. The range of helium concentrations that can be accurately measured in irradiated HAFMs extends from  $10^{-14}$  to  $10^{-1}$  atom fraction. This range permits the HAFMs to be tested in low fluence environments yet to work equally well for high fluence situations.

4.2 Typically, HAFMs are either individual small solid samples, such as wire segments (3) or miniature encapsulated samples of small crystals of powder (4), as shown in Fig. 1. As with radiometric dosimetry, different materials are used to provide different energy sensitivity ranges. Encapsulation is necessary for those HAFM materials and reactor environment combinations where sample melting, sample contamination, or loss of generated helium could possibly occur. Additionally, encapsulation generally facilitates the handling and identification of the HAFM both prior to and following irradiation. The contents of HAFM capsules typically range from 0.1 to 10 mg.

4.3 Following irradiation, encapsulated HAFMs are cleaned and identified in preparation for helium analysis. Helium analysis is then accomplished by vaporizing both the capsule and its contents and analyzing the helium in the resulting gases in a high sensitivity mass spectrometer system (5). The amount of  ${}^4\text{He}$  is determined by measuring the  ${}^4\text{He}$ -to- ${}^3\text{He}$  isotopic ratio in the sample gases subsequent to the addition of an accurately calibrated amount of  ${}^3\text{He}$  “spike.” Unencapsulated HAFMs, for example, pure element wires, are usually etched to remove a predetermined layer of outer material before helium analysis (3). This eliminates corrections for both cross contamination between samples and  $\alpha$ -recoil into or out of the sample during the irradiation.

4.4 The  ${}^4\text{He}$  concentration in the HAFM, in general terms, is proportional to the incident neutron fluence. Consideration must, however, be made for such factors as HAFM material burnup, neutron self-shielding and flux depression,  $\alpha$ -recoil, and neutron gradients. Corrections for these effects are dis-

cussed more fully in Section 13. Generally, they total less than 5 % of the measured helium concentration. Since the individual corrections are usually known to within 50 %, the total error from these corrections amounts to  $\leq 2$  %. Sources of uncertainty also lie in the HAFM material mass, isotopic composition, and mass spectrometric helium analysis. As indicated in Section 13, however, these uncertainties generally contribute less than 1 % of the total uncertainty for routine analyses.

4.5 Applying the above corrections to the measured HAFM helium concentration, the total incident neutron fluence (over the energy range of sensitivity of the HAFM) can be obtained directly from a knowledge of the spectrum-integrated total helium production cross section for the particular irradiation environment. At the present time, the uncertainty in the derived neutron fluence is mainly due to uncertainty in the spectrum-integrated cross section of the HAFM sensor material rather than the combined uncertainties in the helium determination process. This situation is expected to improve as the cross sections are more accurately measured, integrally tested in benchmark facilities (6), and reevaluated.

## 5. Significance and Use

5.1 The HAFM test method is one of several available passive neutron dosimetry techniques (see, for example, Test Methods E854 and E1005). This test method can be used in combination with other dosimetry methods, or, if sufficient data are available from different HAFM sensor materials, as an alternative dosimetry test method. The HAFM method yields a direct measurement of total helium production in an irradiated sample. Absolute neutron fluence can then be inferred from this, assuming the appropriate spectrum integrated total helium production cross section. Alternatively, a calibration of the composite neutron detection efficiency for the HAFM method may be obtained by exposure in a benchmark neutron field where the fluence and spectrum averaged cross section are both known (see Guide E2005).

5.2 HAFMs have the advantage of producing an end product, helium, which is stable, making the HAFM method very attractive for both short-term and long-term fluence measurements without requiring time-dependent corrections for decay. HAFMs are therefore ideal passive, time-integrating

<sup>4</sup> The boldface numbers in parentheses refer to the list of references appended to this test method.

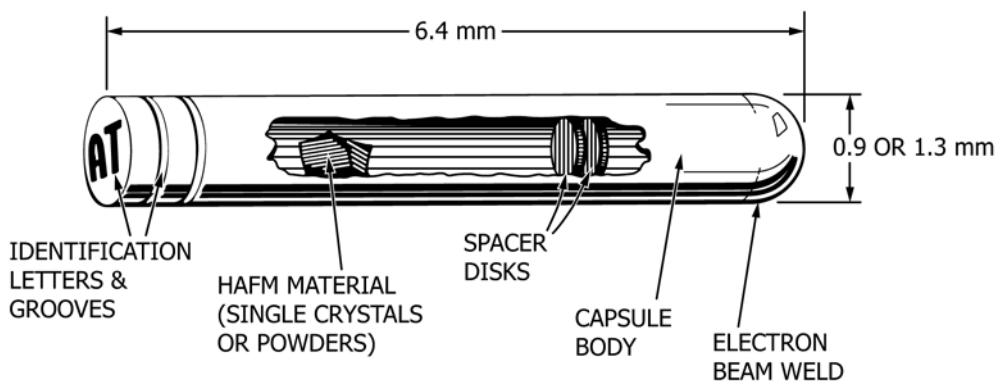

FIG. 1 Helium Accumulation Fluence Monitor Capsule

fluence monitors. Additionally, the burnout of the daughter product, helium, is negligible.

5.2.1 Many of the HAFM materials can be irradiated in the form of unencapsulated wire segments (see 1.1.2). These segments can easily be fabricated by cutting from a standard inventoried material lot. The advantage is that encapsulation, with its associated costs, is not necessary. In several cases, unencapsulated wires such as Fe, Ni, Al/Co, and Cu, which are already included in the standard radiometric (RM) dosimetry sets (Table 1) can be used for both radiometric and helium accumulation dosimetry. After radiometric counting, the samples are later vaporized for helium measurement.

5.3 The HAFM method is complementary to RM and solid state track recorder (SSTR) foils, and has been used as an integral part of the multiple foil method. The HAFM method follows essentially the same principle as the RM foil technique, which has been used successfully for accurate neutron dosimetry. Various HAFM sensor materials exist which have significantly different neutron energy sensitivities from each other. HAFMs containing  $^{10}\text{B}$  and  $^6\text{Li}$  have been used routinely in LMFBR applications in conjunction with RM foils. The resulting data are entirely compatible with existing adjustment methods for radiometric foil neutron dosimetry (refer to Guide E944).

5.4 An application for the HAFM method lies in the direct analysis of pressure vessel wall scrapings or Charpy block surveillance samples. Measurements of the helium production in these materials can provide in situ integral information on the neutron fluence spectrum. This application can provide dosimetry information at critical positions where conventional dosimeter placement is difficult if not impossible. Analyses must first be conducted to determine the boron, lithium, and other component concentrations, and their homogeneities, so that their possible contributions to the total helium production can be determined. Boron (and lithium) can be determined by converting a fraction of the boron to helium with a known thermal neutron exposure. Measurements of the helium in the material before and after the exposure will enable a determi-

nation of the boron content (7). Boron level down to less than 1 wt. ppm can be obtained in this manner.

5.5 By careful selection of the appropriate HAFM sensor material and its mass, helium concentrations ranging from  $\sim 10^{-14}$  to  $10^{-1}$  atom fraction can be generated and measured. In terms of fluence, this represents a range of roughly  $10^{12}$  to  $10^{27}$  n/cm<sup>2</sup>. Fluence (>1 MeV) values that may be encountered during routine surveillance testing are expected to range from  $\sim 3 \times 10^{14}$  to  $2 \times 10^{20}$  n/cm<sup>2</sup>, which is well within the range of the HAFM technique.

5.6 The analysis of HAFMs requires an absolute determination of the helium content. The analysis system specified in this test method incorporates a specialized mass spectrometer in conjunction with an accurately calibrated helium spiking system. Helium determination is by isotope dilution with subsequent isotope ratio measurement. The fact that the helium is stable makes the monitors permanent with the helium analysis able to be conducted at a later time, often without the inconvenience in handling caused by induced radioactivity. Such systems for analysis exist, and additional analysis facilities could be reproduced, should that be required. In this respect, therefore, the analytical requirements are similar to other ASTM test methods.

## 6. Apparatus

6.1 *High-Sensitivity Gas Mass Spectrometer System*, capable of vaporizing both unencapsulated and encapsulated HAFM materials and analyzing the resulting total helium content is required. A description of a suitable system is contained in Ref (5).

6.2 *Analytical Microbalance for Accurate Weighing of HAFM Samples*, minimum specifications: 200-mg capacity with an absolute accuracy of  $\pm 0.5$   $\mu\text{g}$ . Working standard masses must be traceable to appropriate national or international mass standards. Additionally, a general purpose balance with a capacity of at least 200 g and an accuracy of 0.1 mg is required for weighing larger specimens.

**TABLE 1 Neutron Characteristics of Candidate HAFM Materials for Reactor Vessel Surveillance**

HAFM Sensor Material	Principal Helium Producing Reaction	Thermal Neutron Cross Section, (b)	Fission Neutron Spectrum	
			Cross Section, (mb) <sup>A</sup>	90 % Response Range, (MeV) <sup>A</sup>
Li	$^6\text{Li}(n,\alpha)\text{T}$	942	457	0.167–5.66
Be	$^9\text{Be}(n,\alpha)^6\text{He}$ ;ra $^6\text{Li}$	...	284	2.5–7.3
B	$^{10}\text{B}(n,\alpha)^7\text{Li}$	3838	494	0.066–5.25
N	$^{14}\text{N}(n,\alpha)^{11}\text{B}$	...	86.2	1.7–5.7
F	$^{19}\text{F}(n,\alpha)^{16}\text{N}$	...	27.6	3.7–9.7
Al <sup>B</sup>	$^{27}\text{Al}(n,\alpha)^{24}\text{Na}$	...	0.903	6.47–11.9
S	$^{32}\text{S}(n,\alpha)^{29}\text{Si}$	...	...	...
Cl	$^{35}\text{Cl}(n,\alpha)^{32}\text{P}$	...	~13 (Cl)	2.6–8.3
Ti <sup>B</sup>	$^{47}\text{Ti}(n,\alpha)^{44}\text{Ca}$	...	0.634 (Ti)	6.5–12.8
Fe <sup>B</sup>	$^{56}\text{Fe}(n,\alpha)^{53}\text{Cr}$	...	0.395 (Fe)	5.2–11.9
Ni <sup>B</sup>	$^{58}\text{Ni}(n,\alpha)^{55}\text{Fe}$	...	5.58 (Ni)	3.9–10.1
Cu <sup>B</sup>	$^{63}\text{Cu}(n,\alpha)^{60}\text{Co}$	...	0.330	4.74–11.1
316-SS PV Steel Charpy Block	Helium Production Largely from $^{56}\text{Fe}$ and $^{58}\text{Ni}$			

<sup>A</sup> Evaluated  $^{235}\text{U}$  fission neutron spectrum averaged helium production cross section and energy range in which 90 % of the reactions occur. All values are obtained from ENDF/B-V Gas Production Dosimetry File data. Bracketed terms indicate cross section is for naturally occurring element.

<sup>B</sup> Often included in dosimetry sets as a radiometric monitor, either as a pure element foil or wire or, in the case of aluminum, as an alloying material for other elements.

6.3 *Laminar flow (optional) clean benches*, for use in the preparation of HAFM samples and capsules.

6.4 *Stereo microscope*, with 7 to 30 magnification, a ~0.1-mm graticule, and an optical illuminator.

6.5 *Electron beam welder*, with moveable platform stage, for sealing HAFM capsules, minimum specifications: variable beam power to 0 to 1 kW, variable beam size capable of focusing down to a diameter of 0.5 mm. Controls must also be available to permit automatic control of beam duration and onset and offset beam power slopes.

6.6 High temperature vacuum furnace for out-gassing HAFM materials, capsules, and mass spectrometer system furnace components. Minimum specifications: 1000°C at a maximum pressure of  $10^{-5}$  Torr.

6.7 *Micro-sand blaster/cleaner*, for cleaning mass spectrometer vacuum furnace parts.

6.8 *X-ray machine*, for quality assurance test of HAFM capsules. Minimum specifications; 300 kV, 10 mA, 4-mm spot size with control of source distance to 1.0 m and exposure time to 5 min.

6.9 *General Laboratory Supplies:*

6.9.1 *Ultrasonic Cleaner*—100 to 200 W,

6.9.2 *Heat Lamp*—250 W, and

6.9.3 *Optical Pyrometer*—700 to 2000°C.

6.10 *Radioactive Material Handling:*

6.10.1 Lead shielding,

6.10.2 Portable radioactive ( $\beta$ - $\gamma$ ) counters (0.01 mrem/h to 100 rem/h), and

6.10.3 Radioactive waste disposal capability.

6.11 *Reagents and Materials:*

6.11.1 *Hydrochloric Acid (HCl)*, (37 %),

6.11.2 *Hydrofluoric Acid (HF)*, (48 %),

6.11.3 *Nitric Acid (HNO<sub>3</sub>)*, (70 %),

6.11.4 *Sulfuric Acid (H<sub>2</sub>SO<sub>4</sub>)*, (96 %),

6.11.5 *Acetone [(CH<sub>3</sub>)<sub>2</sub>CO]*—Reagent grade (>99.7 %),

6.11.6 *Alcohol (C<sub>2</sub>H<sub>5</sub>OH)*—Pure (200 proof),

6.11.7 *Chloroform (CHCl<sub>3</sub>)*—Reagent grade (>99.2 %),

6.11.8 *Distilled and Deionized Water*, and

6.11.9 *Detergent Cleaning Solution* (Alconox<sup>5</sup> or equivalent).

## 7. HAFM Materials

7.1 *General Requirements*—The general requirements concerning the characteristics of HAFM materials fall into two broad categories: (1) nuclear properties, and (2) chemical properties. These two categories are discussed separately below.

7.2 *Nuclear Properties:*

7.2.1 *Helium Production Cross Section*—Consideration must be made for the energy range or energy sensitivity of the (*n*, total helium) cross section of the potential HAFM sensor material. For any given neutron environment, the set of

HAFMs or combination of HAFMs, RM, and SSTR multiple foils must be chosen to cover the entire neutron energy range (refer to Guide E844). The majority of potential HAFM materials fall into the threshold reaction category. That is, below the threshold energy (usually in the 1–10 MeV range), these materials produce essentially no helium from neutron reactions. Above this energy, however, the (*n*, total helium) cross section generally rises fairly rapidly to a plateau from where it continues to rise relatively slowly. Generally, the higher the threshold energy, the lower the total cross section. The threshold reaction HAFM isotopes presently identified as being most suitable for reactor vessel surveillance are <sup>9</sup>Be, <sup>14</sup>N, <sup>19</sup>F, <sup>27</sup>Al, <sup>32</sup>S, <sup>35</sup>Cl, <sup>56</sup>Fe, <sup>58</sup>Ni and <sup>63</sup>Cu (see Table 1).

7.2.1.1 The two stable isotopes that have significant non-threshold helium production cross sections are <sup>6</sup>Li and <sup>10</sup>B. The cross sections of these two isotopes, which are large and well known, vary inversely with the neutron velocity below about 0.1 MeV. Above 0.1 MeV, the cross section behavior becomes more irregular, with the <sup>6</sup>Li exhibiting a significant resonance near 0.24 MeV.

7.2.1.2 Other stable isotopes exist which have nonthreshold helium production cross sections, but all are much less than 1 barn ( $10^{-24}$  cm<sup>2</sup>). Of the radioactive isotopes, <sup>59</sup>Ni, which has a ~12 barn thermal neutron (*n*, $\alpha$ ) cross section, is the only one important for HAFM neutron dosimetry through the two-stage reaction <sup>58</sup>Ni(*n*, $\gamma$ )-<sup>59</sup>Ni(*n*, $\alpha$ )-<sup>56</sup>Fe. Also included in Table 1 are additional potential HAFM materials which are already included in the standard specified RM foil and metallurgical sets (refer to Matrix E706) and thus may serve a double purpose (see 11.1). These materials include the natural elements Ti, Fe, Cu, and Ni; stainless steel dosimetry capsule material, RV steel; and Charpy block metallurgical specimens. Relevant characteristics of the various HAFM isotopes and materials are listed in Table 1. Aluminum is also often included in RM sets in the form of alloys of Co and Au.

7.2.2 *Activation Cross Sections*—Also to be considered in the selection of HAFM materials is their relative activation cross sections in typical reactor vessel neutron fields. Although activation reactions in general do not interfere with helium production (exceptions are cases of two-stage reactions as with <sup>58</sup>Ni, and cases where daughter products have contributing (*n*, $\alpha$ ) reactions such as <sup>9</sup>Be(*n*, $\alpha$ )-<sup>6</sup>He  $\rightarrow$  <sup>6</sup>Li), the resulting radioactive decay contributes to post-irradiation handling and analysis difficulties and, to this extent, should be minimized.

7.2.3 *Neutron Self-Shielding*—High cross section isotopes, such as <sup>6</sup>Li and <sup>10</sup>B, exhibit significant neutron self-shielding and surface flux depression in thermal and epithermal neutron environments. In order to apply these isotopes to reactor surveillance dosimetry, dilution of these materials by alloying is required to reduce their effective isotopic concentrations. Suitable alloying materials for boron and lithium at the 0.1 to 0.5 weight percent level are vanadium, niobium, and aluminum. Additional details on self-shielding are given in Section 13.

7.2.4 *Neutron Screening at Low Energies*—An alternate technique, or one that can be used in conjunction with alloying to reduce neutron self-shielding, is to protect the boron and lithium from low-energy neutrons by covering with appropriate

<sup>5</sup> Alconox is a registered trademark of Alconox Inc., 215 Park Ave. South, New York, NY 10003.

materials. Cadmium or gadolinium provides a low-energy neutron cutoff of  $\sim 0.5$  eV. A considerably higher cutoff energy can be achieved by shielding with boron carbide ( $B_4C$ ). For 1 keV neutrons,  $\sim 4.5$  cm of  $B_4C$  provides  $\sim 90\%$  attenuation. Because of the neutron perturbation effects of  $B_4C$ , however, this latter technique would be useful only at ex-vessel surveillance locations.

**7.3 Sensor Chemical Properties**—Various considerations must be made concerning the chemical properties of the HAFM sensor materials. Many of the HAFM isotopes, such as  $^6Li$ ,  $^7Li$ ,  $^{14}N$ , etc., are conveniently usable only in compound form. Examples of suitable compounds are  $^6LiF$ ,  $^7LiF$ ,  $TiN$ , and  $ZrN$ . In the choice of the most useful compound, consideration must be given to such factors as: (1) helium production and activation cross sections of the host element (F, Ti, and Zr in the above examples), (2) homogeneity and stoichiometry of the compound, (3) residual impurities such as boron or lithium, (4) stability and resistance to decomposition at higher temperatures, (5) alloying potential with the encapsulating material, and (6) melting and vaporization temperatures, which are important when it comes to releasing the helium for mass spectrometric analysis.

**7.4 HAFM Material Encapsulation**—Encapsulation is necessary for those HAFM sensor materials and irradiation conditions for which there is a potential for either contamination, loss of generated helium from  $\alpha$ -recoil or diffusion, or loss of sensor material itself. This includes those HAFM compounds which are in the form of fine powders or crystals, or which may melt at the temperatures anticipated in the irradiation environment. The encapsulating material must be chosen so as to completely contain the HAFM sensor and its generated helium, while at the same time having relatively low helium production and activation cross sections. The former is of importance for total helium production since the entire HAFM sensor plus capsule is later analyzed for helium. The latter is of importance in minimizing induced radioactivity in the HAFM capsule. Further requirements are that the encapsulating material must be reasonably durable to withstand handling before and after irradiation and that the material be both machinable and weldable to facilitate HAFM capsule fabrication. Generally, when it has been determined that the HAFM sensor material has itself the required helium retention, strength, and chemical inertness, the HAFM is used in the form of a “bare” wire segment without being encapsulated (3).

## 8. HAFM Material Processing

**8.1 HAFM sensor and encapsulating materials** must be analyzed for possible residual helium by pre-irradiation analysis of the various lot materials. In this regard, precautions should be taken to ensure that no helium has been used (as an inert gas) during any stage of material fabrication.

**8.2 HAFM and encapsulating materials** must also be analyzed for thermal neutron helium producing impurities (for example,  $^6Li$  and  $^{10}B$  at sub-ppm levels). As discussed previously, this is most effectively done by helium analysis of a sample of each lot of material following a thermal neutron irradiation. The concentration and homogeneity of alloys

containing low weight contents of boron and lithium (discussed earlier in 7.2.3) can also be determined in this way.

## 9. Manufacture of HAFMs

### 9.1 HAFM Capsules:

**9.1.1 Fabrication and X-ray Qualification**—As discussed previously, encapsulation of HAFM sensor material is necessary in those cases where contamination, loss of sensor material, or loss of internally generated helium could occur. A typical HAFM capsule is shown in Fig. 1. These capsules generally are 6.4-mm long, with outside diameters of 0.9 or 1.3 mm and inside diameters ranging from 0.5 to 1 mm. To ensure no loss of internally generated helium, capsule walls must have a minimum thickness of 0.17 mm. This is most easily verified by X-ray inspection of each empty capsule from two perpendicular angles. To minimize time and cost, the capsules may be X-rayed in groups of approximately 100. Various X-ray conditions have been investigated, and from these tests, it has been determined that optimum capsule definition is obtained by enclosing the capsules in stainless steel hypodermic tubing during the X-ray procedure. The stainless steel serves both as a convenient holder and aligning material, and it has the effect of lowering the X-ray exposure to the film at the capsule edge. In this manner, a “sharp” material density edge for the X-rays is achieved, resulting in a well-defined capsule edge. Following the X-ray procedure, either the X-ray negatives or enlargement prints can be visually scanned using a calibrated magnifier to locate capsules whose central holes are not concentric and whose minimum wall thicknesses may fall outside the allowable limits. The X-ray negatives or prints should be kept on permanent file, with some means of identification for later tracing individual capsules back to the X-ray records.

**9.1.1.1** In addition to the capsule X-ray number, each HAFM capsule should have an alphanumeric identification code stamped on the solid base, and as well may have one or two identifying grooves around the circumference. In this manner, individual capsules or groups of capsules can be identified remotely during post-irradiation hot cell recovery.

**9.1.2 HAFM Material Mass**—Encapsulated HAFM sensor materials can range in mass from single crystals (for example,  $^{10}B$  or  $^6LiF$ ) weighing less than 0.1 mg to fine crystalline powders weighing up to 10 mg. In each case, the total HAFM material mass should be determined using a microbalance and preferably a double substitution weighing scheme, in which the samples are compared with the working standard masses. Periodic calibration of the working standards must be made relative to appropriate national or international mass standards. Total mass accuracy, using this technique, is generally better than  $\pm 0.3 \mu g$ . For single crystals, the mass is best determined prior to loading. For the finer crystalline powders, however, the most reliable and accurate method of determining the mass is by weighing the HAFM capsule before and after loading.

**9.1.3 Capsule Welding**—Because of the need to exclude air, with its natural helium content, from the HAFM interior, weld closure of the capsule top is best accomplished by electron beam under vacuum. This form of welding has the additional advantage of precise control of weld power and heating zone.

TIG welding, an alternate technique, would involve closure under an inert gas atmosphere which could complicate later helium analysis.

9.1.3.1 After HAFM material loading and prior to capsule welding, thin spacer disks should be placed above the sensor material to reflect the heat from the weld zone (see Fig. 1). This is followed by partially closing the capsule top to facilitate the weld process. This can be accomplished either by insertion of a solid plug or by squeezing the top portion of the capsule together. Some gaps should be left in the capsule top to allow for complete evacuation (or inert gas backfilling) prior to final closure. To further reduce HAFM sensor material heating during welding, the lower portion of each capsule should be in firm contact with a suitable heat sink, “chill block.” The length of the weld zone should be limited to the top ~1 mm of capsule.

9.1.4 *Final Capsule Weighing*—As an additional aid in pre- and post-irradiation identification, the final welded capsules should be weighed to an accuracy of at least  $\pm 10 \mu\text{g}$ . Therefore, if part of the alphanumeric identification base code becomes unreadable, capsule identification would still be likely. Additionally, this additional weighing step reveals any possible HAFM material mass loss during the welding process. In this respect, capsule weighings before and after loading should include the actual spacer disks and weld cap (if applicable) to be used (see 9.1.3).

## 10. HAFM Analysis

10.1 *Outline of Test Method*—Determination of the helium content in HAFM materials is made by vaporizing the materials under vacuum. Immediately before the sample is vaporized and the  $^4\text{He}$  is released, a precisely-known amount of  $^3\text{He}$  is added ( $^3\text{He}$  “spike”). After mixing of the two isotopes, the gas passes over getters that remove unwanted gases, then passes into the mass spectrometer volume, which is isolated from its vacuum pump for “static mode” operation. The measurement of the  $^4\text{He}/^3\text{He}$  ratio and a knowledge of the mass of the HAFM material then produces the helium concentration. A recommended helium analysis system has been described previously (5). Precautions must be taken to account for  $^3\text{He}$  that might already be present in the HAFM (see 10.3.1).

### 10.2 Apparatus:

10.2.1 *Mass Spectrometer*—Magnetic sector mass spectrometer with all-metal tube and an interior volume of about 1 L. The instrument should have an electron impact ion source, electron multiplier, and an electrometer with current measuring capability of at least  $10^{-13}$  A with a stability of  $<10^{-14}$  A/h. Output from the electrometer can be monitored directly via a strip chart recorder or digitally averaged for real-time computer analysis. The mass resolving power of the mass spectrometer itself should be a minimum of 50 with a mass scanning range from 2 to 50 amu. Mass scanning capability is useful in checking for possible interfering background gases. In addition, the entire system should be bakeable to 300°C.

10.2.2 *Vacuum System*—To minimize the time necessary to pump away gas samples between analyses, a multiple vacuum system consisting of several independent subsystems should be used. Rapid pumpout can best be accomplished, especially in

the case of helium, when sequential pumping is employed. A rotary pump and then a turbomolecular pump first remove most of the helium very rapidly. As soon as the lower limit is reached, an ion pump is used to reduce the vacuum to a lower level. Finally, another ion pump is used only to maintain the mass spectrometer in the  $10^{-9}$  Torr range between analyses.

10.2.3 *Furnaces*—Several methods have been successfully used to vaporize HAFM materials. For small samples ( $\leq 2$  mg) with melting temperatures less than  $\sim 1800^\circ\text{C}$ , the samples can be readily vaporized in small resistance-heated 0.25-mm diameter tungsten wire coil baskets (2). Larger samples ( $>2$  mg), including HAFM capsules or samples with melting temperatures above  $1800^\circ\text{C}$ , can be vaporized in larger resistance-heated cylindrical graphite crucibles (4.8-mm OD, 20-mm long) (2). Prior to loading, the tungsten coil baskets and graphite crucibles should be degassed in vacuum by heating to  $\sim 1750^\circ\text{C}$  for about 2 min. Vacuum furnaces have been constructed that contain up to ten individual tungsten coils or graphite crucibles. The design of the vacuum furnaces must allow vaporization of samples with masses ranging from about 0.5 to 200 mg (the heavier masses are associated with encapsulated HAFMs). During analysis, the current through the baskets or crucibles is steadily increased until decomposition of the tungsten or graphite occurs. In this manner, vaporization of the enclosed sample and total helium release is assured. For maximum sensitivity for very low level samples, the heating can be stopped prior to tungsten or graphite decomposition provided it can be ascertained that all HAFM sensor material has been vaporized. This reduced heating generally reduces the amount of helium “background” released by the furnace itself.

10.2.3.1 A third furnace type has been used to vaporize larger metallic samples with melting points up to  $\sim 1200^\circ\text{C}$  (8). This furnace uses a graphite crucible which is resistance heated and then maintained at a constant temperature of  $\sim 2000^\circ\text{C}$ . Samples are dropped individually by remote means into the heated crucible and vaporized. The fact that the furnace temperature remains essentially constant during the analysis procedure reduces the uncertainty in the furnace “blank” — the amount of helium attributable to the furnace itself. This reduced uncertainty has the effect of lowering the effective detection limit of the mass spectrometer system. Using this technique, samples with masses up to  $\sim 1$  g can be analyzed, with a resulting helium analysis uncertainty of  $\sim 1 \times 10^8$  atoms. In copper, this is equivalent to a helium concentration of  $\sim 10^{-14}$  atom fraction.

10.2.4 *Getters*—A system of getters should be used to purify the helium gas sample before it is admitted into the mass spectrometer, and to maintain a high vacuum in the mass spectrometer while it is being operated in the static mode. The getters could consist, for example, of a liquid-nitrogen-cooled charcoal trap, followed by, but separated from, a nonevaporable alloy getter (such as the SAES GT-50). Another alloy getter should be permanently attached to the mass spectrometer itself to maintain the vacuum while the instrument is isolated from its ion pump during sample analysis.

10.2.5 *Spike System*—A network of accurately calibrated volumes which dispenses known quantities of  $^3\text{He}$  and  $^4\text{He}$ , for