



# Standard Test Method for Evaluation of the Load Carrying Capacity of Lubricants Under Conditions of Low Speed and High Torque Used for Final Hypoid Drive Axles<sup>1</sup>

This standard is issued under the fixed designation D 6121; the number immediately following the designation indicates the year of original adoption or, in the case of revision, the year of last revision. A number in parentheses indicates the year of last reapproval. A superscript epsilon ( $\epsilon$ ) indicates an editorial change since the last revision or reapproval.

## 1. Scope

1.1 This test method is commonly referred to as the L-37 test.<sup>2</sup> This test method covers a test procedure for evaluating the load-carrying, wear, and extreme pressure properties of a gear lubricant in a hypoid axle under conditions of low-speed, high-torque operation.

1.2 The values stated in inch-pound units are to be regarded as the standard. The SI values given in parentheses are provided for informational purposes only.

1.3 *This standard does not purport to address all of the safety concerns, if any, associated with its use. It is the responsibility of the user of this standard to establish appropriate safety and health practices and determine the applicability of regulatory limitations prior to use.* Specific hazard information is given in Sections 4, 7, and 8.

## 2. Referenced Documents

### 2.1 ASTM Standards:

D 235 Specification for Mineral Spirits (Petroleum Spirits) (Hydrocarbon Dry Cleaning Solvent)<sup>3</sup>

### 2.2 Military Specification:<sup>4</sup>

MIL-PRF-2105E Lubricating Oil, Gear, Multipurpose

### 2.3 AGMA National Standard:<sup>5</sup>

Nomenclature of Gear Tooth Failure Modes

### 2.4 SAE Standard:

SAE J308 Information Report on Axle and Manual Transmission Lubricants<sup>6</sup>

<sup>1</sup> This test method is under the jurisdiction of ASTM Committee D02 on Petroleum Products and Lubricants and is the direct responsibility of Subcommittee D02.B on Automotive Lubricants.

Current edition approved June 10, 2001. Published July 2001. Originally published as D 6121-97. Last previous edition D 6121-00.

<sup>2</sup> Until the next revision of this test method, the ASTM Test Monitoring Center (TMC) will update changes in this test method by means of Information Letters. This edition includes all Information Letters through No. 00-2. Information Letters may be obtained from the ASTM Test Monitoring Center, 6555 Penn Ave, Pittsburgh, PA 15206, Attn: Administrator. The TMC is also the source of reference oils.

<sup>3</sup> *Annual Book of ASTM Standards*, Vol 06.04.

<sup>4</sup> Standardization Documents Order Desk, Bldg 4, Section D, 700 Robbins Avenue, Philadelphia, PA 19111-5094, Attn: NPODS.

<sup>5</sup> American Gear Manufacturers Assn., 1500 King St., Suite 201, Alexandria, VA 22314.

<sup>6</sup> Available from Society of Automotive Engineers, 400 Commonwealth Dr., Warrendale, PA 15096-0001.

## 3. Terminology

### 3.1 Definitions of Terms Specific to This Standard:

3.1.1 *abrasive wear, n*—on ring and pinion gears, removal of material from the operating surface of the gear caused by lapping of mating surfaces by fine particles suspended in lubricant, fuel, or air or imbedded in a surface (CRC Rating Manual No. 18).<sup>7</sup>

3.1.2 *adhesive wear, n*—on ring and pinion gears, removal of material from the operating surface of the gear caused by shearing of junctions formed between operating surfaces in direct metal-to-metal contact; sheared-off particles either remain affixed to the harder of the mating surfaces or act as wear particles between the surfaces (CRC Rating Manual No. 18).

3.1.3 *burnish, n*—on ring and pinion gears, an alteration of the original manufactured surface to a dull or brightly polished condition (CRC Rating Manual No. 17).<sup>7</sup>

3.1.4 *corrosion, n*—in final drive axles, a general alteration of the finished surfaces of bearings or gears by discoloration, accompanied by roughening not attributable to mechanical action (CRC Rating Manual No. 17).

3.1.5 *deposits, n*—in final drive axles, material of pasty, gummy, or brittle nature adhering to or collecting around any of the working parts (CRC Rating Manual No. 17).

3.1.6 *discoloration, n*—on ring and pinion gears, any alteration in the normal color of finished steel surfaces (CRC Rating Manual No. 17).

3.1.7 *pitting, n*—on ring and pinion gears, small irregular cavities in the tooth surface, resulting from the breaking out of small areas of surface metal (CRC Rating Manual No. 17).

3.1.8 *ridging, n*—on ring and pinion gears, an alteration of the tooth surface to give a series of parallel raised and polished ridges running diagonally in the direction of sliding motion, either partially or completely across the tooth surfaces of gears (CRC Rating Manual No. 17).

3.1.9 *rippling, n*—on ring and pinion gears, an alteration of the tooth surface to give an appearance of a more or less regular pattern resembling ripples on water or fish scales (CRC Rating Manual No. 17).

3.1.10 *scoring, n*—on ring and pinion gears, the rapid removal of metal from the tooth surfaces caused by the tearing

<sup>7</sup> Available from Coordinating Research Council (CRC), 219 Perimeter Ctr. Pkwy., Atlanta, GA 30346.

out of small contacting particles that have welded together as a result of metal-to-metal contact. The scored surface is characterized by a matte or dull finish (CRC Rating Manual No. 17).

3.1.11 *scratching, n—on ring and pinion gears*, an alteration of the tooth surface in the form of irregular scratches, of random length, across the tooth surface in the direction of sliding of the surfaces (CRC Rating Manual No. 17).

3.1.12 *spalling, n—on ring and pinion gears*, the breaking out of flakes of irregular area of the tooth surface, a condition more extensive than pitting (CRC Rating Manual No. 17).

3.1.13 *surface fatigue, n—on ring and pinion gears*, the failure of the ring gear and pinion material as a result of repeated surface or subsurface stresses that are beyond the endurance limit of the material. It is characterized by the removal of metal and the formation of cavities (AGMA National Standard).

3.1.14 *wear, n—on ring and pinion gears*, the removal of metal, without evidence of surface fatigue or adhesive wear, resulting in partial or complete elimination of tool or grinding marks or development of a discernible shoulder ridge at the bottom of the contact area near the root or at the toe or heel end of pinion tooth contact area (abrasive wear) (CRC Rating Manual No. 17).

#### 4. Summary of Test Method

4.1 Prior to each test run, inspect the test unit (final axle assembly) and measure and record confirming manufacturing specifications.

4.2 Begin the test when the axle assembly is installed on the test stand and charged with test lubricant.

4.3 *Gear Conditioning Phase*—Run the charged test unit for 100 min at 440 wheel r/min and 394 lbf-ft (535 Nm) torque per wheel, maintaining an axle sump temperature of 297°F (147°C). (**Warning**—High-speed rotating equipment, electrical shock, high-temperature surfaces.)

4.4 Allow for axle assembly to cool and perform a gear inspection. (**Warning**—See 4.3.)

4.5 *Gear Test Phase*—Next, run the test unit for 24 h at 80 wheel r/min, 1742 lbf-ft. (2351 Nm) torque per wheel and an axle sump temperature of 275°F (135°C). (**Warning**—See 4.3.)

4.6 The test is completed at the end of the gear test phase. Visually inspect the test parts.

4.6.1 Remove the ring gear, pinion, and pinion bearing, and rate for various forms of distress. Use the condition of the ring gear and pinion to evaluate the performance of the test oil.

#### 5. Significance and Use

5.1 This test method measures a lubricant's ability to protect final drive axles from abrasive wear, adhesive wear, plastic deformation, and surface fatigue when subjected to low-speed high-torque conditions. Lack of protection can lead to premature gear or bearing failure, or both.

5.2 This test method is used, or referred to, in the following documents:

5.2.1 American Petroleum Institute (API) Publication 1560.<sup>8</sup>

5.2.2 STP-512A.<sup>9</sup>

5.2.3 SAE J308.

5.2.4 Military Specification MIL-PRF-2105E.

#### 6. Apparatus

6.1 *Test Unit*—The test unit is a new complete hypoid truck axle assembly less axle shafts, Dana Model 60, 5.86 to 1 ratio.<sup>10</sup> See Annex A6 for part numbers.

6.2 *Test Stand and Laboratory Equipment*:

6.2.1 *Axle Vent*—Vent the axle to the atmosphere throughout the entire test and arrange the vent so that no water enters the housing.

6.2.2 *Axle Cover*—The axle cover has a 3.5-in. (8.9-cm) inspection port installed, as shown in Fig. A2.1. This allows filling the axle and provides a means for inspecting the axle after the gear condition phase (see 10.1). Install a thermocouple, as described in 6.2.4.1

6.2.3 *Test Stand Configuration*—Mount the complete assembly in a rigid fixture as shown in Fig. A3.1. Mount the test unit in the test stand with pinion and axle shaft centerlines horizontal.

6.2.4 *Temperature Control*—The test axle housing shall include a means of maintaining the lubricant at a specified temperature. This shall include a thermocouple, a temperature recording system, and a cooling method.

6.2.4.1 *Thermocouple*—Determine the thermocouple location on the rear cover using the cover plate temperature sensor locating device as shown in Fig. A4.1.

(a) Install the thermocouple such that the thermocouple tip is flush with the cover plate lip by placing the cover plate face on a flat surface and inserting the thermocouple into the cover plate until the thermocouple tip is flush with the flat surface.

(b) Lock the thermocouple into place.

6.2.4.2 *Temperature Recording System*—The temperature recording system shall record the temperature of the test oil throughout the test.

6.2.4.3 *Axle Cooling*—Use three spray nozzles to distribute water over the cover plate and axle housing as shown in Fig. A5.1. Actuate the water control valve by the temperature control system.

6.2.5 *Power Source*—The power source consists of a gasoline-powered V-8 engine capable of maintaining test conditions.

6.2.6 *Dynamometers and Torque Control System*—Use two axle dynamometers with sufficient torque absorbing capacity to maintain axle torque and speed conditions. Suitable control equipment with sensitivity of adjustment to permit maintenance of test conditions is required.

6.2.7 *Dynamometer Connecting Shafts*—Fabricate shafts connecting the dynamometer to the axle shafts. Shafts must be

<sup>8</sup> "Lubricant Service Designations for Automotive Manual Transmissions, Manual Transaxles, and Axles," available from American Petroleum Institute, 1220 L St. NW, Washington, DC 20005.

<sup>9</sup> "Laboratory Performance Tests for Automotive Gear Lubricants Intended for API GL-5 Service."

<sup>10</sup> Dana Corp., P.O. Box 2424, Fort Wayne, IN 46801.

strong enough to handle the torques encountered and be balanced up to 1200 r/min.

6.2.8 *Drive Shaft and Universal Joints*—Fabricate a shaft with universal joints connecting the manual transmission and test axle. The shaft shall have a 4-in. (10.1-cm) outside diameter with a 0.094-in. (0.26-cm) wall thickness. Shaft and universal joints should be strong enough to handle the torques encountered and be balanced up to 5000 r/min.

6.2.9 *Transmission and Coupling*—Couple the engine to the test unit through a clutch and manual transmission of sufficient torque carrying capacity to operate normally under test conditions.

6.3 *Speed Measuring and Control System*, capable of measuring speed of both axles and also of maintaining test conditions.

## 7. Reagents and Materials

7.1 *Sealing Compound*, where necessary, Permatex No. 2, or equivalent.

7.2 *Solvent*, hydrocarbon solvent that will evaporate at room temperature, leaving no residue. (**Warning**—Combustible, vapor harmful.)

## 8. Preparation of Apparatus

8.1 *Cleaning of Reusable Hardware*—Clean as necessary all reusable parts including axle shafts, thermocouples axle housing cover, and all associated drain pans and funnels used for the addition of and collection of test oil.

### 8.2 Preparation of Axle:

8.2.1 *Pretest Pattern Procedure (optional)*—Check pinion and ring gear pattern in accordance with Dana procedures.<sup>10</sup> Make adjustments as necessary to allow the test unit to have a gear tooth pattern centered on the drive side of the gear teeth.

8.2.2 *Cleaning*—Wash the test unit, using hydrocarbon solvent (**Warning**—see 7.2), paying particular attention to the pinion bearings to remove all preservative oil. Dry by blowing with clean, dry compressed air.

8.2.3 Install axle shafts in test unit.

8.2.4 Lubricate the carrier bearings, pinion bearings, differential gears, and the ring gear and pinion, using the test lubricant or neutral base oil.

8.2.5 *Break and Turn Torque Measurements*—Determine and record the torques required to break and to turn the pinion shaft of the completely assembled test unit.

8.2.6 *Backlash Measurements*—Remove the cover plate. Record backlash at four equally spaced locations. The average of the four readings shall be from 0.004 to 0.009 in. (0.102 to 0.229 mm).

8.3 Install the test unit on the stand with pinion and axle shaft centerlines horizontal. Connect dynamometers and drive shaft to the test unit.

8.4 Bolt the axle cover with gasket (apply sealant, if needed) onto the axle housing and fill the axle assembly with  $6.0 \pm 0.1$  pt ( $2.8 \pm 0.05$  L) of test lubricant. This step may occur before or after the test unit is installed on the stand as described in 8.3.

## 9. Calibration and Standardization

### 9.1 Reference Oils and Hardware:

9.1.1 Reference oils for stand calibration are available from

the ASTM Test Monitoring Center (TMC)<sup>2</sup> and approved hardware through ASTM Subcommittee D02.B0.03.<sup>11</sup>

9.1.2 Do not submit reference oils to physical or chemical analyses for identification purposes. Identifying the oils by analyses could undermine the confidentiality required to operate an effective blind reference oil system. Therefore, reference oils are supplied with the explicit understanding that they will not be subjected to analyses other than those specified within this procedure unless specifically authorized by the TMC. In such cases where analyses are authorized, supply written confirmation of the circumstances involved, the data obtained, and the name of the person authorizing the analysis to the TMC.

### 9.2 Stand Calibration:

9.2.1 Laboratories wishing to calibrate test stands using reference oils and approved hardware shall participate in the Lubricant Test Monitoring System (LTMS) calibration program administered for this test method by the TMC (see Annex A1). The TMC distributes reference oils as blind coded samples for test stand calibration. Report all test starts and test data using reference oils to the TMC. Calibration frequency is subject to change as required. Current calibration information is available from the TMC. Send all reference oil test results to the TMC within five (5) days of test completion. Extensions to this response time may be granted only with prior approval of the TMC.

9.2.2 The TMC shall inspect new test stands for compliance with this test method. A test stand is considered new when a test stand is moved. Additionally, circumstances involving significant changes to stand apparatus, instrumentation, and operation may require an existing test stand to meet new test stand calibration requirements. Consult with the TMC regarding these matters.

9.2.3 *Reference Test Frequency*—One reference test is required every two months or after 650 test hours on non-reference fluids, whichever occurs first.

9.2.4 When a test stand is out of calibration for a period of six months or longer, renumber the stand, and follow LTMS guidelines for new stand introduction.

9.2.5 Report modification of test stand apparatus or completion of any nonstandard test on a calibrated test stand to the TMC immediately. The TMC will determine whether another calibration test is necessary.

9.2.6 Alternate testing of L-37 and L-42<sup>12</sup> tests does not necessitate recalibration as long as the above requirements are met.

9.3 Every test start on any test stand shall receive a sequential test run number designated before testing begins. All tests, including aborted starts and operationally invalid tests, must retain their test number.

9.4 *Instrumentation Calibration*—Calibrate the axle speed measuring system, temperature control system, and torque measuring system to occur at a maximum of four months or 50 tests against a known standard traceable to the National

<sup>11</sup> The responsible ASTM surveillance panel.

<sup>12</sup> Available from ASTM Headquarters.



Institute of Standards and Technology (NIST)<sup>13</sup> or a physical constant.

## 10. Test Procedure

### 10.1 Gear Conditioning Phase:

10.1.1 Set the temperature control to maintain a lubricant temperature of  $297 \pm 3^\circ\text{F}$  ( $147.2 \pm 1.7^\circ\text{C}$ ). See Table A6.1 for alternate versions.

10.1.2 With the engine warmed up and with no load on the dynamometers, shift smoothly to a gear appropriate for the test conditions.

10.1.3 After reaching the appropriate gear, accelerate smoothly to  $440 \pm 5$  wheel r/min and apply dynamometer load to achieve a torque load of  $395 \pm 15$  lbf-ft ( $533 \pm 20$  Nm) on each wheel (see Note 1).

NOTE 1—The time required to accelerate to the test conditions of 440 wheel r/min and 395 lbf-ft is about 2 min.

10.1.4 The test starts when required speed and torque conditions are reached. Record the time as start of the test.

10.1.5 After reaching speed and load conditions, run the test for  $100 \pm 1$  min.

10.1.6 To ensure accuracy of the test, record speed, load, and temperature at a minimum of once every 10 min.

10.1.7 At the end of 100 min, close the throttle smoothly, shift transmission to neutral, and record ending time and temperature of the lubricant.

10.1.8 At this time, an optional inspection of the gear set condition is permitted. If chosen, remove the inspection plug located at the top of the axle cover and note the condition of the ring gear in accordance with CRC Rating Manual 17.

### 10.2 Gear Test Phase:

10.2.1 Set the temperature control to maintain a lubricant temperature of  $275 \pm 3^\circ\text{F}$  ( $135.0 \pm 1.7^\circ\text{C}$ ). See Table A6.1 for alternate versions.

10.2.2 With the engine warmed up and with no load on the dynamometers, shift smoothly to a gear appropriate for the test conditions.

10.2.3 After reaching the appropriate gear, accelerate smoothly to  $80 \pm 1$  wheel r/min and a dynamometer load to achieve a wheel torque load of  $1740 \pm 35$  lbf-ft ( $2349 \pm 47$  Nm).

10.2.4 The test phase starts when required speed, torque, and temperature conditions are reached. Record the time as start of the test phase.

10.2.5 After reaching speed, load, and temperature conditions, run the test for  $24 \pm 0.2$  h.

10.2.6 To ensure test accuracy, record speed, load, and temperature at a minimum of once every hour.

10.2.7 At the end of 24 h, close the throttle smoothly, shift the transmission to neutral, and record time and temperature of the lubricant.

10.2.8 Disconnect the drive shaft and axle shafts from the dynamometers, and remove the test unit from the test stand while the test unit is hot.

## 11. Axle Post Test Measurements

### 11.1 Break and Turn Torques:

11.1.1 While the unit is hot, determine and record the torque required to break and to turn the pinion shaft of the completely assembled test unit.

11.1.2 Allow the unit to cool, and record the torques required to break and to turn the pinion shaft of the completely assembled test unit.

11.2 Drain the axle of test lubricant. This may occur anytime after 10.2.7 has been completed.

11.3 Backlash Measurements—Remove the cover plate. Record backlash at four equally spaced locations on the ring gear and calculate the average of the four readings.

11.4 Completely disassemble the differential and the pinion shaft assemblies for inspection.

## 12. Determination of Test Results<sup>14</sup>

### 12.1 Pinion Bearing Rating:

12.1.1 Examine the bearings for wear, surface fatigue corrosion, and deposits in accordance with CRC Rating Manual 17.

### 12.2 Gear Rating:

12.2.1 Examine the tooth surfaces on the drive side of the pinion and ring gear for the following distresses in accordance with CRC Rating Manual 17 and Annex A9: burnishing, wear, pitting/spalling, ridging, rippling, scoring, discoloration, corrosion, and deposits. Rate the distress types of wear, rippling, and ridging using the CRC Reference Photography of Gear Distress photographs. The photographs shall have a serial number of SN001 or greater and have an issuance date of July 8, 2000 or later.

12.2.2 Rate each distress by identifying its level of distress in accordance with Table A9.1. Four distress types (ridging, rippling, scoring, and wear) are assigned a numerical value between 0 and 10 corresponding to the rated level of distress, as shown in Table A9.1. The pitting/spalling distress type is assigned numerical values also shown in Table A9.1.

12.2.3 When using the nonlubricated hardware, gear set C1L426/P4L415A, determine a numerical pitting/spalling value, excluding any pitting/spalling value between 9.3 and 9.9, inclusively, in the wear step area of the drive side pinion tooth, as per Annex A10.

12.2.3.1 When using the nonlubricated hardware, gear set V1L303/P4L514A, determine a numerical pitting/spalling value, excluding any pitting/spalling value between 3.0 and 9.9, inclusive, in the wear step area of the drive side pinion tooth, as per Annex A10.

12.2.3.2 Report this rating value on Figs. A7.2 (Form 1) and A7.4 (Form 2) for reference oil tests and Figs. A7.3 (Form 1A) and A7.4 (Form 2) for non-reference oil tests of the test report package.

12.2.3.3 A second pitting/spalling value obtained in either case may be determined by including any pitting/spalling in the wear step area of the drive side pinion tooth, as per Annex A10. If this rating method is used, report this rating value in the comment section on Fig. A7.6 (Form 4) of the test report

<sup>13</sup> National Institute of Standards and Technology (formerly National Bureau of Standards), Gaithersburg, MD 20899.

<sup>14</sup> Available from ASTM Headquarters. Request RR: D02-1415.

package for information only.

12.3 When using gear set V1L686/P4L626A, a thin polished line visible in the root heel of the pinion and on the crown of the ring gear may be evident. The polish line may vary in length and prominence due to the build position of the ring and pinion gears and manufacturing accuracy of the carrier. This condition is normal and not oil related. Note this condition in the final test report comment section as *Root and Tip line polishing and a function of the gear set manufacturing process — V1L686/P4L626A*.

12.4 For a test rating to be valid, the gears shall be rated by an individual who has participated in a CRC sponsored, high-volume, gear-rater calibration workshop within the previous twelve months.<sup>15</sup>

12.5 *Test Validity*—The test is determined to be operationally valid if the percent deviation of the critical operating parameters and number of shutdowns are within the limits specified and defined in Annex A8.

### 13. Report

13.1 Report all information shown in the current report format, which is available from the TMC.

13.2 Attach the temperature recording trace for the test as part of the report.

13.3 When reporting reference oil test results to the TMC, transmit by facsimile the complete report form package (see Annex A7) within five days of test completion. Within 30 days of test completion, mail a copy of the final test report to the ASTM Test Monitoring Center, 6555 Penn Ave., Pittsburgh, PA 15206-4489. Electronic transfer of test results (see 13.6) is also permitted for approved laboratories.

13.4 Complete all test report forms in accordance with the formats shown in Annex A11 (Data Dictionary). Include a completed report form package in the final test report.

<sup>15</sup> Training for those rating gear sets for gear distress levels may be obtained from Coordinating Research Council, 219 Perimeter Ctr. Pkwy., Atlanta, GA 30346.

13.5 *Deviations from Test Operational Limits*—Report all deviations from specified test operational limits on Form 4 (Fig. A7.6) under Other Comments.

13.6 *Electronic Transmission of Test Results*—Electronic transfer of reference and non-reference oil test report data can be done utilizing the Flat File Transmission Format contained in Section 2 of the ASTM Data Communications Committee Test Report Transmission Model, available from the ASTM TMC.

### 14. Precision and Bias

14.1 *Precision*—Test precision is established on the basis of reference oil test results (for operationally valid tests) monitored by the ASTM TMC. The data are reviewed semi-annually by the L-37 Surveillance Panel. Contact the ASTM TMC for current industry data. Table 1 summarizes reference oil precision of the test as of March 1, 1999.

14.1.1 *Intermediate Precision (i.p.) (formerly called repeatability)*—The difference between two results obtained by the same laboratory with the same gear batch on the same oil would, in the long run, in the normal and correct conduct of the test method, exceed the values shown in Table 1 in only one case in twenty.

14.1.2 *Reproducibility (R)*—The difference between two single and independent results obtained by different laboratories with the same gear batch on the same oil would, in the long run, in the normal and correct conduct of the test method exceed the following value in only one case in twenty.

14.2 *Bias*—No estimate of bias for this test method is possible because the performance results for an oil are determined only under specific conditions of the test and no absolute standards exist.

### 15. Keywords

15.1 abrasive wear; adhesive wear; bearing failure; final drive axle; gear; gear failure; hypoid axle; lubricants; L-37; surface fatigue

**TABLE 1 Reference Oil Test Precision Data**

NOTE 1—These statistics are based on results on Test Monitoring Center Reference Oils 127, 128, 128-1, and 129

Legend:

- $S_{i.p.}$  = intermediate precision standard deviation,
- $i.p.$  = intermediate precision,
- $S_R$  = reproducibility standard deviation, and
- $R$  = reproducibility.

Hardware Type	Variable	$S_{i.p.}$	$i.p.$	$S_R$	$R$
Lubrited	Pinion ridging, -ln(10.5-merit)	0.3836	1.0741	0.3859	1.0805
	Pinion rippling, -ln(10.5-merit)	0.5645	1.5806	0.6412	1.7954
	Pinion wear, merit	1.0181	2.8507	1.0648	2.9814
	Pinion pitting/spalling, -ln(10.5-merit)	0.7124	1.9947	0.7124	1.9947
Non-lubrited	Pinion ridging, -ln(10.5-merit)	0.4847	1.3572	0.5209	1.4585
	Pinion rippling, -ln(10.5-merit)	0.5303	1.4848	0.5993	1.6780
	Pinion wear, merit	1.0352	2.8986	1.0728	3.0038
	Pinion pitting/spalling, -ln(10.5-merit)	0.4298	1.2034	0.4414	1.2359



**D 6121**

**ANNEXES**

**(Mandatory Information)**

**A1. THE ROLE OF THE ASTM TEST MONITORING CENTER (TMC)**

A1.1 The TMC is a nonprofit organization located at 6555 Penn Ave., Pittsburgh, PA 15206. It is staffed to administer engineering studies; conduct laboratory visits; perform statistical analysis of test; to blend, store, and ship reference oils; and to provide associated administrative functions connected with the referencing and calibration of various lubricant tests. The TMC maintains a close connection with test sponsors, test developers, the surveillance panels, and the testing laboratories. The management of these functions is vested in the Test Monitoring Board, whose members are elected by Subcommittee D02.B. The TMC operates under the ASTM Charter and its associated bylaws and regulations, the bylaws of Committee D02 and Subcommittee D02.B, and the Rules and Regulations of the Test Monitoring Board. The operating income of the TMC is obtained from fees levied on the reference oils supplied and on the conduct of the calibration tests. These fees are set by Subcommittee D02.B and are regularly reviewed.

*A1.2 Information Letters:*

A1.2.1 It occasionally becomes necessary to change a test procedure and to notify test laboratories of the change before the change can be considered by Subcommittee D02.B on Automotive Lubricants or Committee D02 on Petroleum Products and Lubricants. In such a case, the TMC will issue an Information Letter. Subsequently, prior to each semiannual Committee D02 meeting, the accumulated Information Letters are balloted in Subcommittee D02.B. This ballot is reviewed at the Subcommittee D02.B meeting, and the actions taken are then considered by Committee D02. In this way, the ASTM due process procedures are applied to the Information Letters.

A1.2.2 The review of an Information Letter prior to its original issue will differ in accordance with its nature. In the case of an Information Letter that does not affect test results,

such as notification of a part number change, the TMC is authorized to issue an Information Letter. A survey or study conducted by the Surveillance Panel resulting in a recommendation for a change in hardware or procedure may result in the issuance of an Information Letter. If urgent change to hardware or procedure are obviously necessary, the test sponsor and the TMC may issue an Information Letter and present it for approval, with the background and data, for approval by the Surveillance Panel prior to the next semiannual Committee D02 meeting.

A1.2.3 Authority for the issue of Information Letters was given by the Committee on Technical Committee Operations (COTCO) in 1984, as follows: “COTCO recognizes that D02 has a unique and complex situation. The use of Information Letters is approved provided that each letter (at its initial issue) contains a disclaimer to the effect that it has not obtained ASTM consensus. These Information Letters should be moved to such consensus as rapidly as possible.”

A1.3 *TMC Memoranda*—In addition to the Information Letter system, the TMC will provide information to the Surveillance Panel and to participating laboratories in the form of ASTM TMC memoranda. These are used to convey such information as batch approvals for test parts or materials, to clarify misunderstandings concerning the test procedure, to provide notes and suggestions for the collection and analysis of special data that the TMC may call for, or for any other matters having no direct effect on the test performance results or precision and bias.

A1.4 *Precision Data*—One measure of test precision is established on the basis of reference oils (calibration) test results monitored by the ASTM TMC. Current data may be obtained from the TMC.

**A2. AXLE COVER EXAMPLE**

A2.1 Fig. A2.1 is an example of an axle cover; Table A2.1 lists the metric equivalents.

**TABLE A2.1 Metric Equivalents for Fig. A2.1**

in.	mm	in.	mm
1/16	1.6	1	25.4
3/8	9.5	2 5/8	66.7
7/8	22.2	3 1/2	88.9

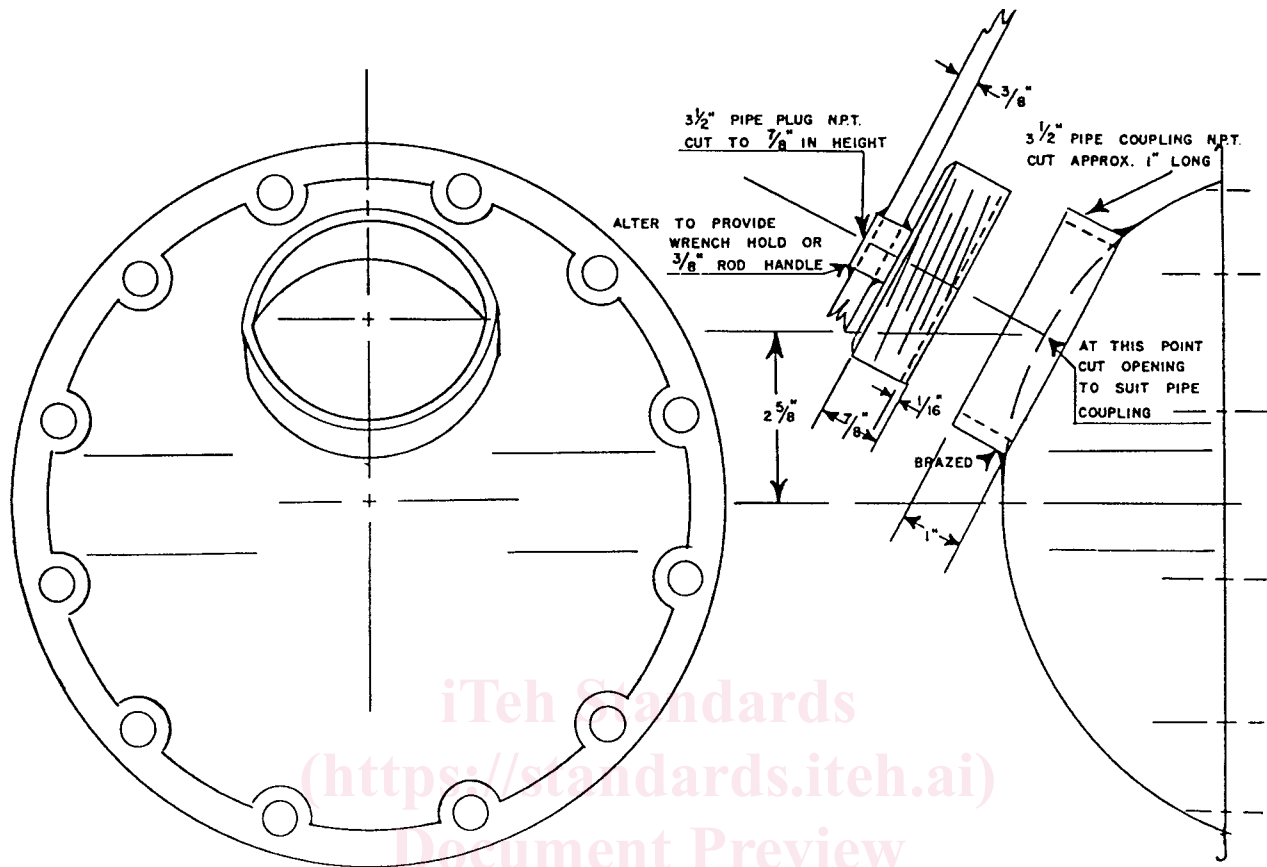

**FIG. A2.1 Axle Cover Example**

ASTM D6121-01

<https://standards.iteh.ai/catalog/standards/sist/3305ecc6-6960-4539-a55c-e30d45ecd60f/astm-d6121-01>

**A3. RIGID AXLE MOUNT EXAMPLE**

A3.1 Fig. A3.1 provides an example of a rigid axle mount on a test stand.

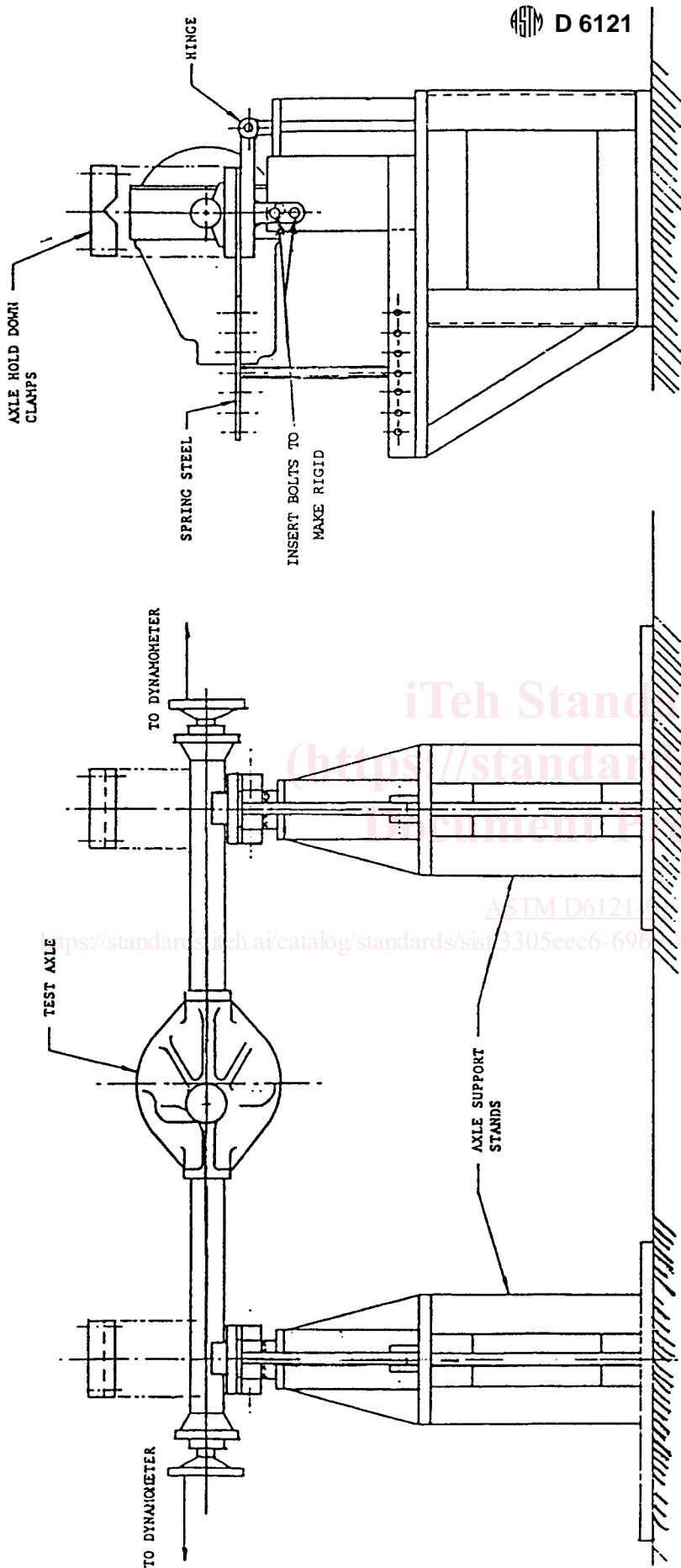
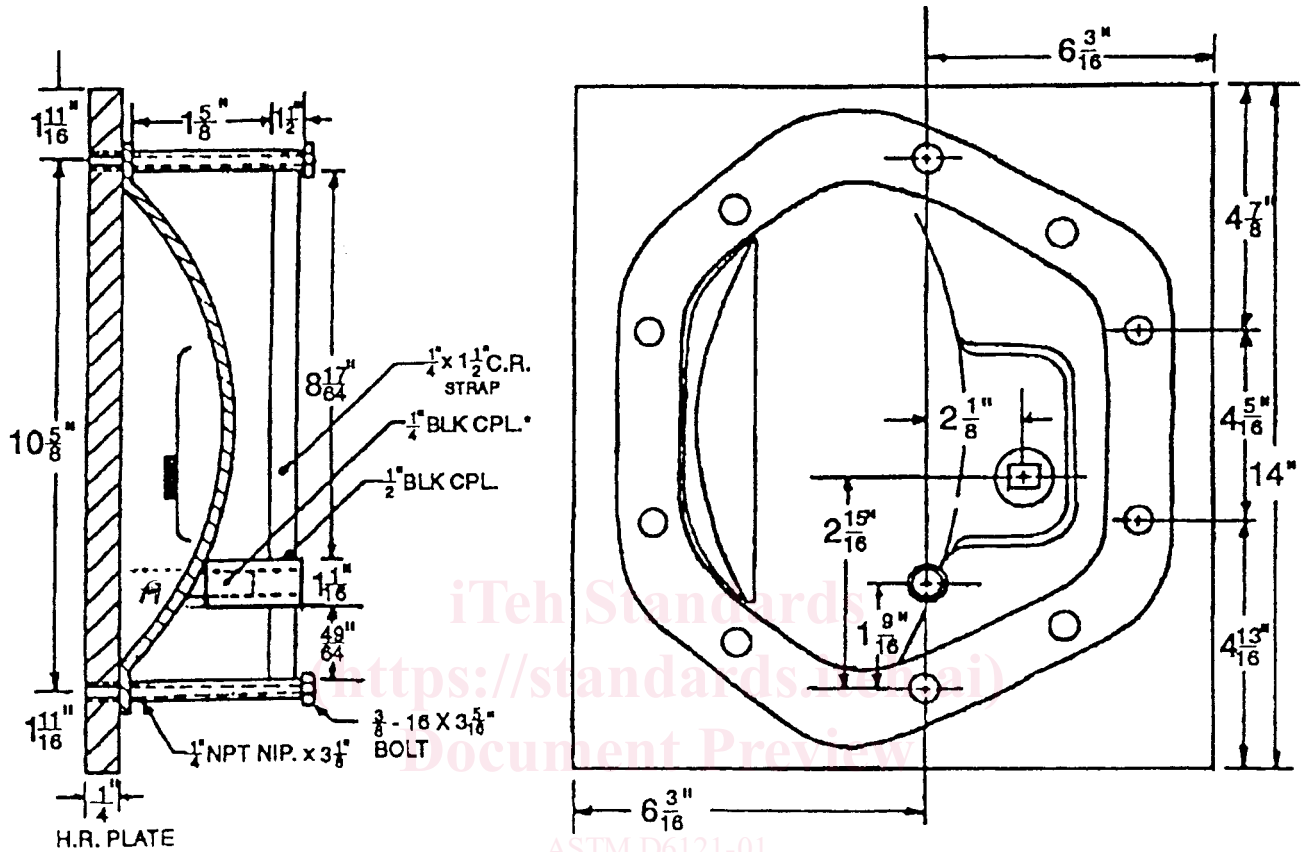

FIG. A3.1 Example of Rigid Axle Mount on Test Stand



**A4. COVERPLATE TEMPERATURE SENSOR LOCATING DEVICE**

A4.1 Fig. A4.1 is an example of a cover plate temperature



A CPL cut a approximately 50° angle (sand cpl to match contour of cover)

**FIG. A4.1 Cover Plate Temperature Sensor Locating Device**

sensor locating device; Table A4.1 lists the metric equivalents.

**TABLE A4.1 Metric Equivalents for Table A4.1**

in.	mm	in.	mm
1/4	6.4	3 1/8	79.4
3/8	9.5	3 5/16	84.1
1/2	12.7	4 5/16	109.5
1 1/16	27.0	4 13/16	122.2
1 1/2	38.1	4 7/8	123.8
1 9/16	39.7	6 3/16	157.2
1 5/8	41.3	8 17/64	209.9
1 11/16	42.9	10 5/8	269.9
2 1/8	54.0	13	330.2
2 15/16	76.6		

**A5. AXLE COOLING SYSTEM**

A5.1 Fig. A5.1 provides the location of spray nozzles on

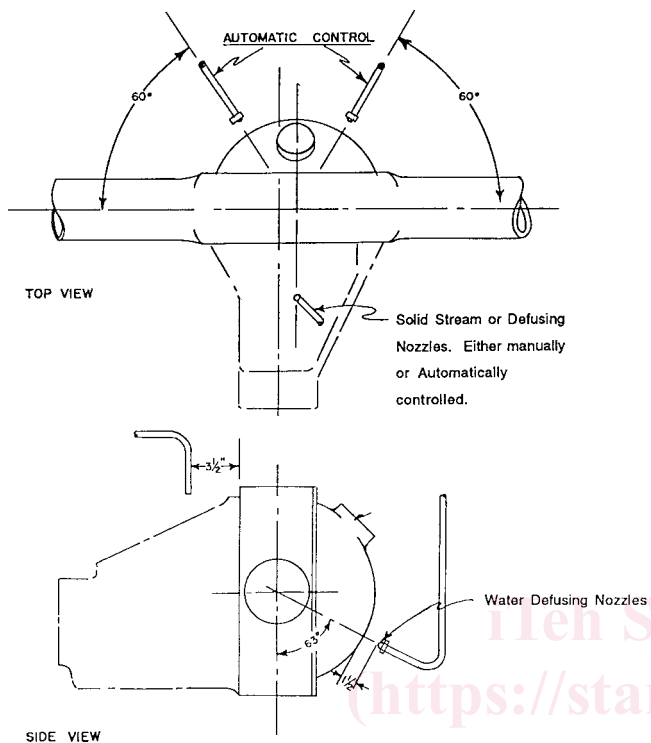

NOTE 1—Use 3/8 in. tubing for all water lines.

**FIG. A5.1 Location of Spray Nozzles on Axle**

the axle; Table A5.1 lists the metric equivalents.

**TABLE A5.1 Metric Equivalents for Fig. A5.1**

in.	mm	in.	mm
3/8	9.5	3 1/2	88.9
1 1/2	38.1		

**A6. TEST VERSIONS AND AXLE PART NUMBERS**

A6.1 *Axle Used in Test*—Two types of test axle are run in this test.

A6.1.1 *Uncoated Axle*—Dana Model 60, 5.86 ratio, standard differential with uncoated ring gear and uncoated pinion, Part No. 060AA100-2.<sup>10</sup> Also referred to as plain or green axles.

A6.1.2 *Coated Axle*<sup>16</sup>—Dana Model 60, 5.86 ratio, standard differential with coated ring gear and coated pinion, Part No. 060AA100-4.<sup>10</sup> Also referred to as lubrited or lubrized axles.

A6.2 *Test Versions*—This test has four commonly used versions. The test procedures and conditions described previously in this test method will be referred to as the standard

version. All versions maintain the same test procedures, wheel load, and wheel speed conditions. The differences occur in the axle oil temperature and axle type used. Table A6.1 describes

**TABLE A6.1 Test Versions<sup>A,B</sup>**

Test Version	Axle Type	Gear Conditioning	
		Axle Temperature	Gear Test Phase Axle Temperature
Standard	uncoated	297 ± 3°F (147.2 ± 1.7°C)	275 ± 3°F (135.0 ± 1.7°C)
Standard	coated	297 ± 3°F (147.2 ± 1.7°C)	275 ± 3°F (135.0 ± 1.7°C)
Canadian	uncoated	220 ± 3°F (104.4 ± 1.7°C)	200 ± 3°F (93.3 ± 1.7°C)
Canadian	coated	220 ± 3°F (104.4 ± 1.7°C)	200 ± 3°F (93.3 ± 1.7°C)

<sup>A</sup> All versions use the same wheel speed, load conditions, and test procedures, which are described in Section 10.

<sup>B</sup> Both Canadian test versions typically used for evaluation of 75W lubricants.

<sup>16</sup> A manganese phosphate coating.

each version.