



Designation: ~~D3498 – 03 (Reapproved 2011)~~ **D3498 – 18**

Standard Specification for Adhesives for Field-Gluing Plywood to Lumber Framing for Floor Systems Wood Structural Panels (Plywood or Oriented Strand Board) to Wood Based Floor System Framing¹

This standard is issued under the fixed designation D3498; the number immediately following the designation indicates the year of original adoption or, in the case of revision, the year of last revision. A number in parentheses indicates the year of last reapproval. A superscript epsilon (ϵ) indicates an editorial change since the last revision or reapproval.

1. Scope

1.1 This specification covers minimum performance standards and test requirements for gap-filling construction adhesives for bonding plywood to lumber framing, particularly floor joists, wood structural panels consisting of plywood or oriented strand board (OSB) to wood based floor system framing, particularly dimension lumber or wood I-joists, at the construction site.

1.2 This specification provides a basis for ensuring the quality of the adhesives and is not intended as an application specification.

1.3 The values stated in inch-pound units are to be regarded as standard. The values given in parentheses are mathematical conversions to SI units that are provided for information only and are not considered standard.

1.4 The following precautionary caveat pertains only to the test method portion, Section 11, of this specification: *This standard does not purport to address all of the safety concerns, if any, associated with its use. It is the responsibility of the user of this standard to establish appropriate safety, health, and health environmental practices and determine the applicability of regulatory limitations prior to use.*

1.5 *This international standard was developed in accordance with internationally recognized principles on standardization established in the Decision on Principles for the Development of International Standards, Guides and Recommendations issued by the World Trade Organization Technical Barriers to Trade (TBT) Committee.*

2. Referenced Documents

2.1 ASTM Standards:²

[D572 Test Method for Rubber—Deterioration by Heat and Oxygen](#)

[D905 Test Method for Strength Properties of Adhesive Bonds in Shear by Compression Loading](#)

[D907 Terminology of Adhesives](#)

~~[D2016 Methods of Test for Moisture Content of Wood \(Withdrawn 1987\)](#)~~³

[D4300 Test Methods for Ability of Adhesive Films to Support or Resist the Growth of Fungi](#)

[D4442 Test Methods for Direct Moisture Content Measurement of Wood and Wood-Based Materials](#)

[D4444 Test Method for Laboratory Standardization and Calibration of Hand-Held Moisture Meters](#)

[D4783 Test Methods for Resistance of Adhesive Preparations in Container to Attack by Bacteria, Yeast, and Fungi](#)

[E4 Practices for Force Verification of Testing Machines](#)

[E177 Practice for Use of the Terms Precision and Bias in ASTM Test Methods](#)

2.2 Voluntary Product Standards:³

[PS1 Structural Plywood](#)

[PS2 Performance Standard for Wood-Based Structural-Use Panels](#)

3. Terminology

3.1 Definitions:

3.1.1 Many terms in this specification are defined in Terminology [D907](#).

¹ This specification is under the jurisdiction of ASTM Committee [D14](#) on Adhesives and is the direct responsibility of Subcommittee [D14.70](#) on Construction Adhesives. Current edition approved Jan. 1, 2011; Feb. 1, 2018. Published January 2011; March 2018. Originally approved in 1976. Last previous edition approved in 2003; 2011 as ~~D3498 – 03~~; ~~D3498 – 03 (2011)~~. DOI: ~~10.1520/D3498-03R11~~; 10.1520/D3498-18.

² For referenced ASTM standards, visit the ASTM website, www.astm.org, or contact ASTM Customer Service at service@astm.org. For *Annual Book of ASTM Standards* volume information, refer to the standard's Document Summary page on the ASTM website.

³ The last approved version of this historical standard is referenced on www.astm.org. Available from National Institute of Standards and Technology (NIST), 100 Bureau Dr., Stop 1070, Gaithersburg, MD 20899-1070, <http://www.nist.gov>.

3.1.2 *gap-filling adhesive, n*—an adhesive capable of forming and maintaining a bond between surfaces that are not close-fitting.

3.1.2.1 *Discussion*—

Close-fitting is relative to a given material and industry; for example, standards in construction differ from standards in electronics. Some adhesives will bond by bridging without completely filling the gap; others by filling the gap completely.

3.1.3 *open assembly time, n*—the time interval between applying adhesive on the substrates and closing them together before bonding.

3.1.4 *oriented strand board (OSB), n*—a mat formed panel product with oriented layers resulting in directional properties.

3.1.5 *plywood, n*—a conventional all-veneer panel with alternate layers of veneer which are orientated perpendicular to each other.

3.1.6 *wood-I joist, n*—a structural member manufactured using sawn or structural composite lumber flanges and structural panel webs, bonded together with exterior exposure adhesives, forming an “I” cross-sectional shape.

4. Significance and Use

4.1 This specification establishes test methods and performance requirements for adhesives bonding plywood or OSB to wood framing members.

4.2 This specification provides a basis for ensuring the quality of the adhesives.

4.3 The tests provide shear strength performance data when the substrates are conditioned to simulate various conditions that may occur during sub-floor adhesive application and curing.

4.4 The tests are suitable for product performance certification and quality control programs, and can be useful to the general public, adhesive manufacturers, distributors, specifiers, architects, contractors, testing laboratories and other businesses and professionals.

4.5 The results do not include all possible conditions, which may occur during final assembly, but indicate a set of performance characteristics for laboratory controlled bonding variables.

4.6 Successful testing compliance with plywood or OSB does not qualify the same adhesive formulation with the other.

5. Ordering Information

5.1 The adhesive may be furnished by the manufacturer in any suitable form agreeable to the purchaser.

6. Materials

6.1 The adhesive shall be a gap-filling construction adhesive that sets at ambient temperatures as low as 40°F (4.4°C).

6.2 The adhesive shall not support mold or bacterial growth. If amylaceous or protein fillers and extenders are used in the adhesive formulation, the adhesive must not only pass the performance requirements of this specification, but in addition, possess sufficient anti-fungal properties to inhibit the growth of selected fungal species when tested in accordance with Test Methods **D4300** and selected bacterial species in accordance with Test Methods **D4783**. The adhesive manufacturer shall notify in writing the agency responsible for testing, certifying, and compliance labeling of the adhesive whether any such materials are present in the adhesive.

6.3 The adhesive, when completely set, shall form a resilient bond that shall be durable when protected from direct exposure to the weather, as defined by the requirements of this specification.

6.4 The adhesive shall be a uniform mixture suitable for extrusion by a caulking gun or other pressurized application equipment.

6.5 The adhesive shall permit an open assembly time of not less than 10 min when applied to the lumber framing in accordance with the manufacturer’s instructions. It shall be functional, as defined in this specification, when applied to surfaces having a temperature range from 0 to 100°F (–17.8 to 37.8°C). Open assembly times less than 10 min, may be used if agreed upon between the manufacturer and user, provided the adhesive meets the requirements of **Table 1, Table 1.**

NOTE 1—Open assembly times that are less than 10 min as agreed upon between the manufacturer and user, are acceptable provided the adhesive meets the requirements of **Table 1.**

6.6 The adhesive shall be functional when applied to lumber framing free of standing water, ice, or snow.

7. Requirements

7.1 The adhesive shall conform to the strength and durability properties shown in **Table 1.**

7.2 Performance of the adhesive for bonding plywood and OSB shall be evaluated separately.

7.3 Adhesive bonding performance with both plywood and OSB shall meet the requirements specified in this standard prior to certification in accordance with Section **14.**

TABLE 1 Adhesive Strength and Durability Requirements

Test	Property	Number of Specimens	Requirement	Section Reference
Test A (wet lumber)				
Douglas-fir	shear strength	24	150 psi (1.035 MPa), min avg	11.2
Southern pine	shear strength	24	150 psi (1.035 MPa), min avg	11.2
Test B (frozen lumber)				
Douglas-fir	shear strength	24	100 psi (0.689 MPa), min avg	11.2
Southern pine	shear strength	24	100 psi (0.689 MPa), min avg	11.2
Test C (dry lumber)				
Douglas-fir	shear strength	24	150 psi (1.035 MPa), min avg	11.2
GAP-filling Douglas-fir	shear strength	24	100 psi (0.689 MPa), min avg	11.3
Durability (moisture resistance)				
Douglas-fir	delamination	24	a minimum of 22 of 24 specimens shall show no delamination.	11.4
	shear strength	24	150 psi (1.035 MPa), min avg	11.4
Durability (oxidation resistance)	flexibility	3	no fracture of free film on mandrel bend or visible signs of melting after exposure	11.5

8. Sampling

8.1 A representative sample totaling not less than 1 qt (946 cm³) of the adhesive shall be taken from each lot to be tested.

8.2 For the purpose of sampling, a lot shall consist of material from the same batch or blending operation subject to the same processing operations and conditions.

9. Number of Tests

9.1 The number of test specimens shall be as specified in each test method designated in Section 11 and Table 1. The average result for the specimens tested shall conform to the requirements prescribed in this specification.

10. Specimen Preparation

10.1 *Materials*—Use the following materials for the tests outlined:

10.1.1 *Plywood*— $\frac{5}{8}$ -in. or $(\frac{19}{32}$ -in. (15.1-mm) (15.1-mm) thick, U.S. Product Standard PS-1-95PS-1 grade marked stamped, commercial plywood, Group 1 Species, exterior glue, or sanded exterior-grade plywood, underlayment type with A grade face ply for the adhesion surface. The plywood must be flat within $\frac{1}{16}$ in. (2 mm); that is, the maximum permissible bow for a 16-in. (406-mm) length of plywood shall be $\frac{1}{16}$ in. (2 mm). Make the measurement across the top surface of the plywood. Use bowed plywood only if it meets the limitation above and if the convexity occurs on the bottom surface that will contact the lumber. The plywood must be free of patches, core voids, and knot holes in the glue line area.

10.1.2 *Oriented Strand Board (OSB)*— $\frac{5}{8}$ -in. or $\frac{19}{32}$ -in. (15.1-mm) thick, U.S. Product Standard PS-2-grade marked stamped. The OSB must be flat within $\frac{1}{16}$ -in. (2 mm); that is, the maximum permissible bow for a 16-in. (406-mm) length of OSB shall be $\frac{1}{16}$ in. (2 mm). Make the measurement across the top surface of the OSB. Use bowed OSB only if it meets the limitation above and if the convexity occurs on the bottom surface that will contact the lumber. The OSB must be free of any defect that could interfere with bonding to lumber substrate. Unless the OSB's grade stamp requires otherwise, the panel surface with the grade stamp shall be used for adhesion. No further surface modification or preparation is permitted.

10.1.3 *Lumber*—2-in. (51-mm) (nominal) Douglas-fir and southern pine; (Note 21) clear dry lumber (moisture content of 8 to 15 %) (Note 32). The surface shall be free of bark, knots, splits, and pitch.

NOTE 1—Only the sapwood of loblolly, slash, longleaf, and shortleaf pine may be used.

NOTE 2—Test Method Method D2016/D4442 shall be used to determine moisture content.

10.1.4 *Adhesive*—applied with a caulking as per the quantity and method recommended by the adhesive manufacturer to ensure full coverage of a $1\frac{1}{2}$ -in. wide lumber surface. The dispensed bead diameter used for test specimen preparation shall be stated in the manufacturer's application instructions as the minimum application for $1\frac{1}{2}$ -in. wide floor system framing. See the product marking requirement in 15.2.5.

10.2 *Number of Test Assemblies*—Prepare three wood-adhesive composite test assemblies as shown in Fig. 1 for each condition specified.

10.3 *Conditioning of Materials:*

10.3.1 Cut lumber and plywood or OSB to the required size as shown in Fig. 1. If the lumber must be reduced in height, retain at least one mill-finished surface as the surface to be bonded. If the lumber must be reduced in width to achieve a maximum $1\frac{1}{2}$ -in. (38-mm) dimension, plane both sides in equal amounts.

10.3.2 Pre-drill the plywood or OSB and lumber with a No. 37 (diameter 0.104 in. (2.64 mm)) to receive nails as shown in Fig. 1. Pre-drill the lumber to a depth of 1 in. (25 mm).

10.3.3 Condition the adhesive at $70 \pm 5^\circ\text{F}$ ($21.1 \pm 2.8^\circ\text{C}$) for a period of 48 h prior to use.

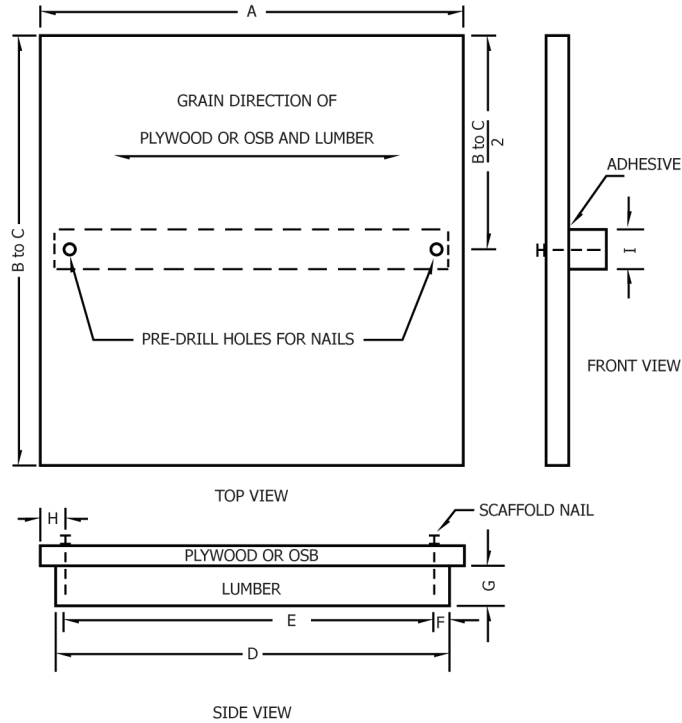

Table of Dimensions

	in.		mm	
	Dimension	Tolerance	Dimension	Tolerance
A	15 3/4	1/8	400	3
B	5 1/2	...	140	...
C	16	...	406	...
D	15	1/8	381	3
E	13	1/8	330	3
F	1	1/8	25	3
G	1 1/2 min	1/16	38 min	2
H	1 3/8	1/16	33	2
I	1 1/2 max	1/16	38 max	2

FIG. 1 Test Assembly

10.3.4 Condition the lumber and plywood or OSB in accordance with the schedules shown in Table 2, and the following procedures:

TABLE 2 Conditioning of Materials before Fabrication of Test Assemblies

Test	Lumber		Plywood or OSB
	Douglas-fir	Southern Pine	
Test A (wet lumber)	48 h soak in water at 70 ± 5°F (21.1 ± 2.8°C), then 48 h at 100 ± 5°F (37.8 ± 2.8°C) and 90 ± 5 % RH, then 15-min soak in water at 70 ± 5°F (21.1 ± 2.8°C)	2 h soak in water at 70 ± 5°F (21.1 ± 2.8°C), then 48 h at 100 ± 5°F (37.8 ± 2.8°C) and 90 ± 5 % RH, then 15 min soak in water at 70 ± 5°F (21.1 ± 2.8°C)	48 h at 100 ± 5°F (37.8 ± 2.8°C) and 90 ± 5 % RH
Test B (frozen lumber)	48 h soak in water at 70 ± 5°F (21.1 ± 2.8°C), then 48 h at 0 ± 5°F (-17.8 ± 2.8°C), with RH uncontrolled	2 h soak in water at 70 ± 5°F (21.1 ± 2.8°C), then 48 h at 0 ± 5°F (-17.8 ± 2.8°C), with RH uncontrolled	48 h at 0 ± 5°F (-17.8 ± 2.8°C), with RH uncontrolled
Test C (dry lumber)	48 h at 100 ± 5°F (37.8 ± 2.8°C) and RH max of 40 %	...	same as lumber
Gap-filling	48 h at 70 ± 5°F (21.1 ± 2.8°C) and 50 ± 10 % RH	...	same as lumber
Durability (moisture resistance)	48 h at 70 ± 5°F (21.1 ± 2.8°C) and 50 ± 10 % RH	...	same as lumber

10.3.4.1 Run Test A (wet lumber) and Test B (frozen lumber) with both Douglas-fir and southern pine lumber.

10.3.4.2 Before fabricating samples with wet lumber surfaces (Test A), seal both ends of the lumber sections with paraffin. Completely submerge the lumber in water at $70 \pm 5^\circ\text{F}$ ($21.1 \pm 2.8^\circ\text{C}$) for 48 h for Douglas-fir, and for 2 h for southern pine. After submersion, wipe off visible surface water and expose the lumber for 48 h at $100 \pm 5^\circ\text{F}$ ($37.8 \pm 2.8^\circ\text{C}$), and $90 \pm 5\%$ relative humidity. At the completion of the humidity cycle, submerge the lumber in water at $70 \pm 5^\circ\text{F}$ ($21.1 \pm 2.8^\circ\text{C}$) for 15 min. Wipe off visible surface water with a clean, dry cloth and immediately begin the fabrication procedure as outlined in 10.4.1.

10.3.4.3 Seal lumber for test assemblies with frozen lumber surfaces (Test B) at both ends with paraffin and submerge in water as described in Table 2. After submersion, wipe off visible surface water with a clean, dry cloth and store immediately at $0 \pm 5^\circ\text{F}$ ($-17.8 \pm 2.8^\circ\text{C}$) for 48 h.

NOTE 3—For safety, conditioning chambers should have no ignition sources within the vapor space.

10.4 Preparation of Shear Strength Specimens:

10.4.1 Apply an adhesive bead along the center line of a mill-finished surface of the lumber, such that the bead extends from one predrilled hole to the other, but not beyond. Apply sufficient adhesive to give 100 % coverage of the lumber surface, as evidenced by a “squeeze-out.” If it is necessary to apply the adhesive outside of the lumber conditioning chamber, remove only one piece of lumber at a time, apply the adhesive bead, then condition the lumber with adhesive applied for a minimum of 10 min and a maximum of 12 min in accordance with Table 3.

10.4.2 Before placing the plywood or OSB on the adhesive-covered surface, insert spacers, ¼ in. wide by 0.006 in. thick by 4 in. long (6 by 0.15 by 102 mm), at the midpoint of the lumber and at the outboard side of each nail, as shown in Fig. 2. Before the spacer is inserted at the midpoint, scrape away a 1-in. (25-mm) segment of the adhesive bead at the midpoint. Do not permit adhesive between the spacer and substrate.

NOTE 4—Aluminum embossing tape is suggested for use as spacers.

10.4.3 Position the plywood or OSB on the adhesive-covered surface with the aid of a positioning jig as shown in Fig. 3. Nail in place with 6-penny (2 in. (51 mm) in length) scaffold nails. Make the top of the lower head of a scaffold nail flush with the surface of the plywood or OSB.

10.4.4 Apply a uniform pressure of 4 ± 0.25 psi (28 ± 2 kPa) across the entire bonded area of the assembly for a period of 1 min at $70 \pm 5^\circ\text{F}$ ($21.1 \pm 2.8^\circ\text{C}$). Apply this pressure by any appropriate means, including a press with a suitable insert between the nails or a combination of uniformly distributed weights between the nails.

10.4.5 Set the adhesive in the assemblies in accordance with the schedules shown in Table 4.

10.4.6 After the specified setting time, remove the nails, but leave the spacers in place. Using a sharp saw, cut off the plywood or OSB flush with the side surfaces of the lumber, at the same time removing any excess adhesive. Cut eight block-shear specimens from each assembly as shown in Figs. 4 and 5.

10.5 Preparation of Specimens for Test of Gap-Filling Effect on Strength—Prepare assemblies as described in 10.4.1 – 10.4.4, except for thickness of spacers. Before placing the plywood on the adhesive-covered lumber surface, insert spacers, ¼ in. wide by 0.062 in. thick by 4 in. long (6 by 1.57 by 102 mm), as shown in Fig. 2. Avoid disturbing the location of the spacers. Do not permit adhesive between the spacer and substrate.

NOTE 5—TFE-fluorocarbon sheet is suggested for use as spacers.

10.5.1 After the specified setting time (Table 4), remove the nails and spacers before cutting eight block-shear specimens from each assembly, as shown in Figs. 4 and 5.

10.6 Preparation of Specimens for Test of Durability (Moisture Resistance)—Prepare assemblies as described in 10.4.1 – 10.4.4. After the specified setting time (Table 4), remove the nails, but leave the spacers in place. Cut eight specimens from each assembly as shown in Fig. 4 and Fig. 6.

10.7 Preparation of Specimens for Test of Durability (Oxidation Resistance).

10.7.1 Prepare specimens by casting wet films of adhesive lengthwise on silicone release paper or polyethylene sheet, as shown in Fig. 7. Control thickness and width of the castings with the spreader shown in Fig. 7. Cast the first film of adhesive using the 0.050-in. (1.27-mm) gap of the spreader. Condition this film for 3 h at $70 \pm 5^\circ\text{F}$ ($21.1 \pm 2.8^\circ\text{C}$) and $50 \pm 10\%$ relative humidity. Then cast a second wet film of adhesive on top of the first film using the 0.100-in. (2.54-mm) gap of the spreader.

TABLE 3 Open Assembly Time Conditions

Test	Temperature	Humidity
Test A (wet lumber)	$70 \pm 5^\circ\text{F}$ ($21.1 \pm 2.8^\circ\text{C}$)	$50 \pm 10\%$ RH
Test B (frozen lumber)	$0 \pm 5^\circ\text{F}$ ($-17.8 \pm 2.8^\circ\text{C}$)	RH uncontrolled
Test C (dry lumber)	$100 \pm 5^\circ\text{F}$ ($37.8 \pm 2.8^\circ\text{C}$)	40 % RH max
Gap-filling	$70 \pm 5^\circ\text{F}$ ($21.1 \pm 2.8^\circ\text{C}$)	$50 \pm 10\%$ RH
Durability (moisture resistance)	$70 \pm 5^\circ\text{F}$ ($21.1 \pm 2.8^\circ\text{C}$)	$50 \pm 10\%$ RH

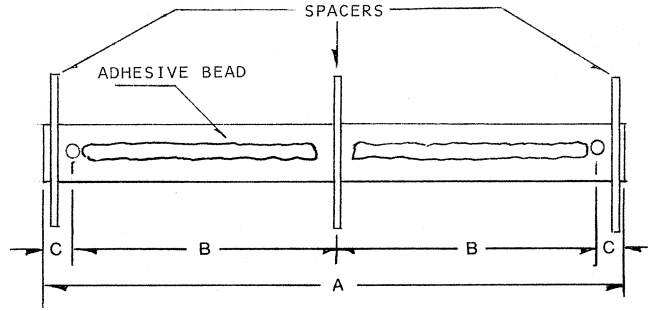

PLACEMENT OF ¼ IN. WIDE BY 0.006 IN. THICK BY 4 IN. LONG (6.00 X 0.15 X 102.00 MM) SPACERS FOR TESTS A, B, C AND DURABILITY (MOISTURE RESISTANCE) AND ¼ IN. WIDE BY 0.062 IN. THICK BY 4 IN. LONG (6.00 X 1.57 X 102.00 MM) SPACERS FOR GAP-FILLING TEST

Table of Dimensions

	in.		mm	
	Dimension	Tolerance	Dimension	Tolerance
A	15	1/8	381	3
B	6½	1/8	165	3
C	1	1/8	25	3
D	13	1/8	330	3

FIG. 2 Placement of Spacers in Test Assemblies

NOTE 6—For adhesives having solids contents in the range from 95 to 100 weight %, the wet film of adhesive may be cast in one step using the 0.100-in. (2.54-mm) gap of the spreader.

10.7.2 Set the completed casting of adhesive at the conditions shown in Table 4. After setting, cut three, 1 by 3-in. (25 by 76-mm) specimens from the free adhesive films.

11. Test Methods

11.1 Test Conditions—Perform all tests of shear strength at 70 ± 5°F (21.1 ± 2.8°C) and 50 ± 10 % relative humidity. Maintain the specimens at these conditions after removal from the setting area, and test within 8 h after setting has been completed.

11.2 Shear Strength (Tests A, B, and C)—Test the specimens for shear strength by compression-shear loading in a testing machine that has an accuracy of ± 1 % when calibrated in accordance with Practices E4. Use a loading rate of 0.20 in. (5 mm)/min. A shearing tool described in Test Method D905 is recommended for these tests, but other equipment may be used, including loading devices that apply compression loads in tension testing machines. The ultimate load for each condition (Tests A and B, each wood species, and Test C) shall be read to the nearest 1 lbf (0.45 N) for each of the 24 specimens (three assemblies per test condition, eight specimens per assembly). After testing, determine the overall bonded area of each test specimen by measuring it, at least once in each dimension, to the nearest 0.010 in. (0.25 mm). Report the shear strengths in pounds-force per square inch (megapascals) for each specimen, together with the overall average of the 24 specimens for each test condition, and for each wood species in Tests A and B.

11.3 Gap-Filling Effect on Strength—Test the 24 specimens as described in 11.2. Report the spacer thickness and shear strengths in pounds-force per square inch (megapascals) for each specimen, together with the overall average of the 24 specimens.

11.4 Durability (Moisture Resistance)—This test is to be run with Douglas-fir lumber only.

11.4.1 Place the specimens in a vacuum-pressure vessel and weight them. Introduce water at 110 ± 5°F (43 ± 2.8°C) until the specimens are completely submerged. Draw a vacuum of 15 in. (381 mm) Hg (51 kPa) and maintain it for 30 min. Release the vacuum and continue to soak the specimens in the same water at atmospheric pressure for 4½ h with no additional heating. Remove specimens from water, then dry them for 16 h in an oven at 150 ± 5°F (66 ± 2.8°C) with forced-air circulation at 45 to 50 air changes per minute.

11.4.2 Immediately after drying, examine the edges of the specimens for adhesive bond failure (delamination) to the plywood or OSB or lumber. Voids in the adhesive bond shall not be considered delamination. Report the number of specimens with and without visible delamination.

11.4.3 After examining the specimens for adhesive bond failure, condition them at 70 ± 5°F (21.1 ± 2.8°C) and 50 ± 10 % relative humidity for 7 days and prepare them as block-shear specimens as shown in Fig. 5. Test the specimens as described in 11.2 to evaluate any degradation in shear strength after exposure to moisture. Report the shear strength in pounds-force per square