



Designation: ~~F2412 – 11~~ **F2412 – 18**

Standard Test Methods for Foot Protection¹

This standard is issued under the fixed designation F2412; the number immediately following the designation indicates the year of original adoption or, in the case of revision, the year of last revision. A number in parentheses indicates the year of last reappraisal. A superscript epsilon (ϵ) indicates an editorial change since the last revision or reappraisal.

INTRODUCTION

For more than sixty years, the predecessor to these test methods, ANSI Z41, established the performance criteria for a wide range of footwear to protect from the hazards that affect the personal safety of workers. The value of these standards was recognized early in the history of the Occupational Safety and Health Administration (OSHA) and incorporated as a reference standard in the Code of Federal Regulation (CFR) Section 1910.

These test methods contains test protocols developed in conjunction with ANSI Z41 as well as other ASTM standards that are used to evaluate the performance of footwear when exposed to a variety of hazards: (1) impact resistance (I) for the toe area of footwear; (2) compression resistance (C) for the toe area of footwear; (3) metatarsal impact protection (Mt) that reduces the chance of injury to the metatarsal bones at the top of the foot; (4) conductive properties (Cd) that reduce hazards that may result from static electricity buildup and reduce the possibility of ignition of explosives and volatile chemicals; (5) electric hazard resistant (EH) non-conductive; (6) static dissipative (SD) properties to reduce hazards due to excessively low footwear electrical resistance that may exist where SD footwear is required; and (7) puncture resistance (PR) of foot devices.

1. Scope

1.1 These test methods measure the resistance of footwear to a variety of hazards that can potentially result in injury.

1.2 These test methods may be used to test for compliance to minimum performance requirements in established safety standards.

1.2.1 By agreement between the purchaser and the supplier, or as required by established safety standards, these test methods can be used to determine any one, or all of the following: (1) impact resistance (I), (2) compression resistance (C), (3) metatarsal impact resistance (Mt), (4) resistance to electrical conductivity (Cd), (5) resistance to electric hazard (EH), (6) static dissipative performance (SD), and (7) puncture resistance (PR).

1.3 The values stated in SI units are to be regarded as the standard. The values given in parentheses are for information only.

1.4 *This standard does not purport to address all of the safety concerns, if any, associated with its use. It is the responsibility of the user of this standard to establish appropriate safety, health, and environmental practices and determine the applicability of regulatory limitations prior to use.*

1.5 *This international standard was developed in accordance with internationally recognized principles on standardization established in the Decision on Principles for the Development of International Standards, Guides and Recommendations issued by the World Trade Organization Technical Barriers to Trade (TBT) Committee.*

2. Referenced Documents

2.1 *ASTM Standards:*²

B117 Practice for Operating Salt Spray (Fog) Apparatus

¹ These test methods are under the jurisdiction of ASTM Committee F13 on Pedestrian/Walkway Safety and Footwear and are the direct responsibility of Subcommittee F13.30 on Footwear.

Current edition approved July 1, 2011; Feb. 1, 2018. Published August 2011; March 2018. Originally approved in 2005. Last previous edition approved in 2005 as F2412 – 05; F2412 – 11. DOI: 10.1520/F2412-11; 10.1520/F2412-18.

² For referenced ASTM standards, visit the ASTM website, www.astm.org, or contact ASTM Customer Service at service@astm.org. For *Annual Book of ASTM Standards* volume information, refer to the standard's Document Summary page on the ASTM website.

2.2 CSA Standard:³

CAN/CSA Z195 Protective Footwear

3. Terminology

3.1 Definitions:

3.1.1 ~~insert/footbed/sockliner (all-removable), footbed (removable), n—footbed normally also known as ‘insock,’ a component typically made of a foam product material with a leather or fabric cover shaped to cover cover/sockliner and often shaped or contoured covering the entire insole board which can be inserted between the foot and insole board.~~

3.1.2 *insole, n*—foundation of the shoe; the inner sole of the shoe which is next to the foot, under the sock liner or insert, onto which the upper is lasted.

3.1.3 *last, n*—solid hinged form, in the general shape of a foot, around which footwear is constructed.

3.1.4 *lasting, v*—building of footwear around a specific foot form.

3.1.5 *lining, n*—term used to describe all components that can be used to construct the interior of the upper portion of the footwear.

3.1.6 *outsole and heel, n*—exterior bottom platform of the footwear; the bottom surface.

3.1.7 ~~product category, n—description for a type of footwear designed and group of similar footwear items manufactured for a specific hazard or hazards.~~ hazards and that:

- Have same protective toe cap, protective insole or metguard materials
- Have the same supplier for each of those components
- Have the same outsole design, compound and hardness (including midsole)
- Have the same thickness (within a ± 12.5 % range) of upper, lining, sole and insole
- Are manufactured using the same method of construction; cemented, welted, etc.
- Are manufactured in the same factory
- Are manufactured using the same last

3.1.8 *product classification, n*—footwear manufactured to meet a minimum performance requirement for a specific hazard or hazards.

3.1.9 *protective footwear, n*—footwear that is designed, constructed, and classified to protect the wearer from a potential hazard or hazards.

3.1.10 *protective toe cap, n*—component designed to provide toe protection that is an integral and permanent part of the footwear.

3.1.11 *quarter, n*—entire back portion of the footwear upper.

3.1.12 *size, n*—length and breadth measurements of footwear determined by using a specific grading; the American system of footwear grading.

3.1.13 *socklining (non-removable), n*—fabric material placed over the insole, footbed, or insert that may be imprinted with a brand name or other designation.

3.1.14 *specimen, for protective footwear, n*—footwear units evaluated for various hazards.

3.1.14.1 *Discussion—*

Footwear units may be a left foot, a right foot, or a matched pair. The exact number and type of footwear units is indicated by test method.

3.1.15 *upper, n*—parts of a shoe or boot that are above the sole.

4. Significance and Use

4.1 These test methods contain requirements to evaluate the performance of footwear for the following:

4.1.1 Impact resistance for the toe area of footwear (I/75),

4.1.2 Compression resistance for the toe area of footwear (C/75),

4.1.3 Metatarsal protection that reduces the chance of injury to the metatarsal bones at the top of the foot (Mt/75),

4.1.4 Conductive properties which reduce hazards that may result from static electricity buildup, and reduce the possibility of ignition of explosives and volatile chemicals (Cd),

4.1.5 Electric Hazard by stepping on live wire (EH),

³ Available from Canadian Standards Association (CSA), 178 Rexdale Blvd., Toronto, ON Canada M9W1R3.

4.1.6 Static dissipative (SD) properties to reduce hazards due to excessively low footwear electrical resistance that may exist where SD footwear is required, and

4.1.7 Puncture resistance footwear devices (PR).

4.2 Any changes to the original components of safety toe footwear such as replacing or adding ~~after-market-after-market~~ footbeds/inserts could cause ~~non-compliance-non-compliance~~ to any or all parts of this standard rendering the ASTM label invalid. Protective toe footwear specimens or samples shall be retested for any of the following changes.

4.2.1 Change in material used to make protective toe cap, change in protective cap manufacturer, change in the design of the toe cap.

4.2.2 Change in construction method used to make footwear or change in factory in which footwear is produced.

4.2.3 Change in the upper or insole material thickness greater than 25 %, change to the soling system or a change in the hardness of the outsole.

4.2.4 Change in shape of last used in the manufacturing of footwear.

4.2.5 Change in material or supplier of protective insole.

4.2.6 Change in material or supplier of met guard.

5. Protective Toe Impact Resistance (I)

5.1 Summary of Method:

5.1.1 Footwear shall be constructed and manufactured so that a protective toe cap is an integral and permanent part of the footwear.

5.1.2 Footwear with a protective toe cap is impacted with a specified force.

5.1.3 After impact, the height of the modeling clay cylinder is measured.

5.2 Apparatus:

5.2.1 The apparatus as shown in [Fig. 1](#) and [Fig. 1\(a\)](#)⁴ consists of a frame structure that permits the impactor to be constrained to fall along a known and repeatable path. Provision shall be made for a mechanism to catch the striker after the initial impact so that the test specimen is struck only once.

5.2.1.1 The impactor consists of a steel weight having a mass of 22.7 ± 0.23 kg (50 ± 0.5 lb). The nose of the impactor is a solid steel cylinder having a diameter of 25.4 ± 0.8 mm (1 ± 0.03 in.) and protruding a length of 50.8 mm (2.0 in.) ± 3.2 mm (2.0 ± 0.13 in.) from the impact assembly. The impact side of the cylinder has a smooth spherical surface with a radius of 25.4 ± 0.127 mm (1.00 ± 0.005 in.). The longitudinal centerline of the cylinder is parallel and coincident ~~with~~within 3.175 mm (0.125 in.) to the ~~symmetry of its vertical axis~~vertical axis of the impactor.

5.2.1.2 Apparatus incorporates a means of measuring the velocity at impact with a tolerance of ± 2 %. The use of a velocity metering system allows for determining the time required for a 25.4-mm (1-in.) wide blade to pass completely through a beam of light immediately prior to the impactor striking the specimen. The result, referred to as gate time, is measured in milliseconds (ms). The speed in in./s can be calculated using the following formula:

$$V = \frac{1000}{t_g} \quad (1)$$

where:

V = velocity in in./s, and

t_g = gate time in ms.

5.2.2 The base of the apparatus consists of a steel plate with a minimum area 0.3 m² (1 ft²) and minimum thickness of 25.4 mm (1 in.). The base is anchored to a structure having a minimum mass of 909.1 kg (2000 lb) to provide sufficient stability to the apparatus before, during, and after testing.

5.3 Sampling:

5.3.1 Randomly select three half-pair test specimens, including both left and right footwear, of each product category from unworn manufactured footwear. If footwear is manufactured with a removable sockliner (footbed) the test is to be performed with the sockliner in place. All testing must be performed at standard conditions of 22°C (± 2 °C) and 50 % RH (± 5 %).

5.3.1.1 Men's footwear specimens shall be ~~obtained from~~ size 9.

5.3.1.2 Women's footwear specimens shall be ~~obtained from~~ size 8.

5.3.2 The specimens shall be obtained by completely removing the toe portion of the footwear. This is done by cutting across the width of the footwear 25.4 ± 3.2 mm (1 ± 0.125 in.) behind the back edge of the protective toe cap and cutting the upper material back to the edge of the protective toe cap as shown in [Fig. 2](#).

⁴ Imagery as shown within Ells, W., Ed., *Safety and Occupational Footwear*, MNL71-EB, ASTM International, 2014.

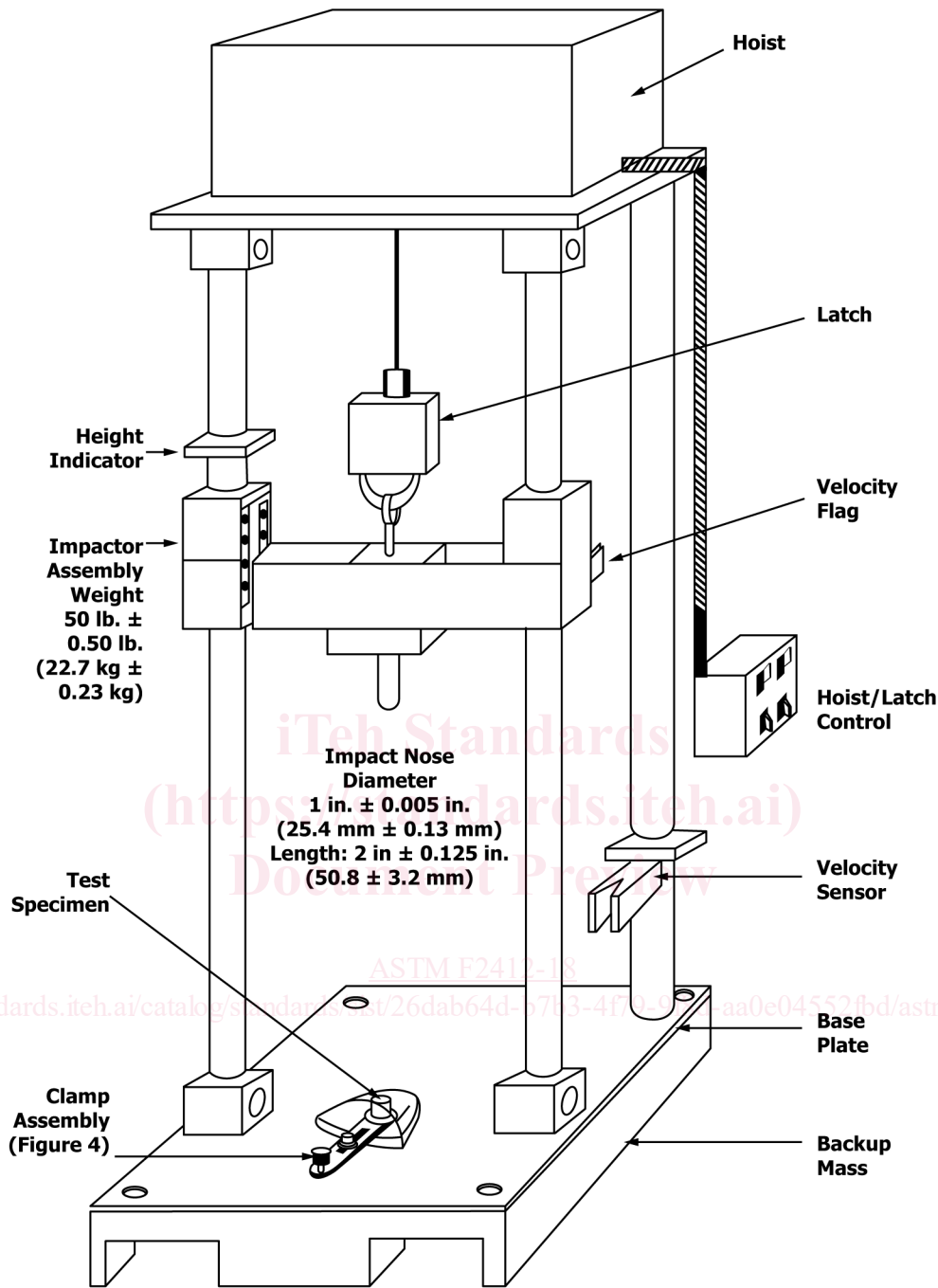

NOTE 1—Dimensions are in inches (millimetres)-(millimeters).

FIG. 1 Footwear Impact Test Apparatus

5.4 Prior to impact testing, modeling clay shall be kept at room temperature standard conditions and formed approximately as a 1 in. diameter vertical cylinder, shall be placed under the protective toe cap to back rear edge of the cap positioned inside the specimens directly under the point of impact (see Fig. 3) with the edge of the clay cylinder aligned with the back edge of the toe cap.

5.4.1 Modeling clay for the test forms shall be stored in a sealed container at room temperature and tested in accordance with 5.4.2 – 5.4.9. Test frequency shall be no less than once every month, month or sooner, if the color or consistency changes. It is recommended that this quality test be conducted on a specimen the clay just prior to its use during an impact test (see Fig. 4).

5.4.2 Weigh out a 50 ± 2 g sample of modeling clay.

5.4.3 Form material into a 35 ± 2 mm (1.375 ± 0.075 in.) cylinder and allow material to sit at room temperature for 24 h.

5.4.4 The modeling clay cylinder shall be placed horizontally vertically on the base plate at the center point of the impact tester.

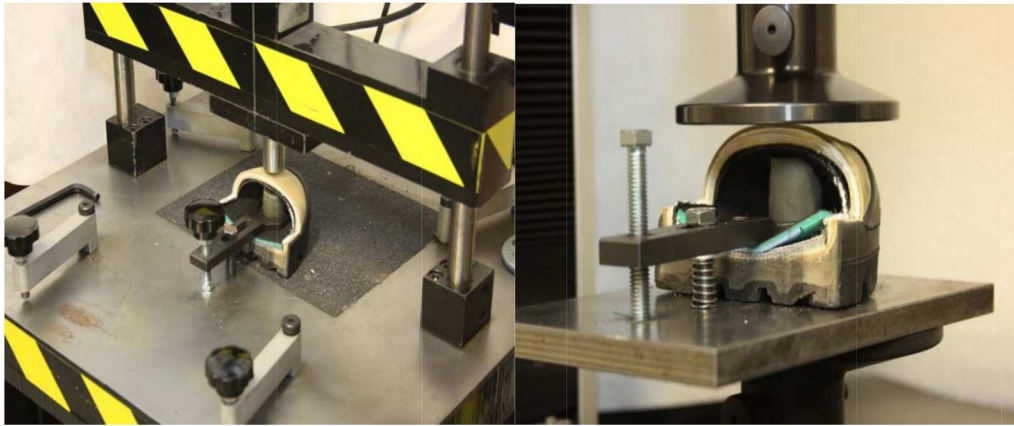

FIG. 1 (a) Impact Testing (Left) and Compression Testing (Right)⁴ (continued)

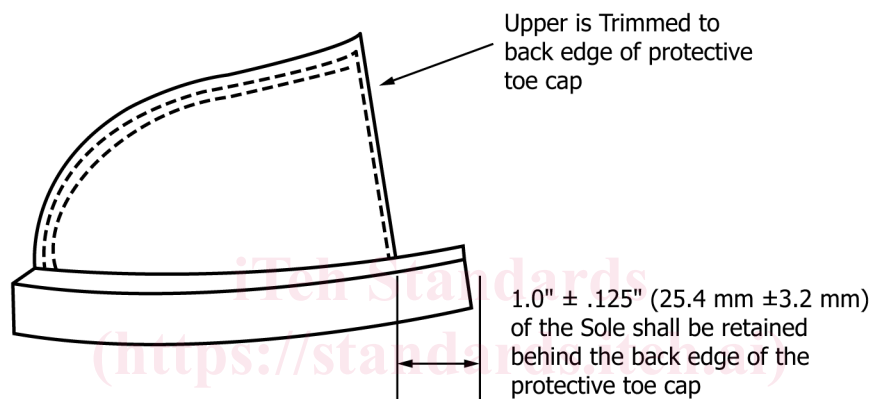

FIG. 2 Specimen Prepared for Impact and Compression Testing

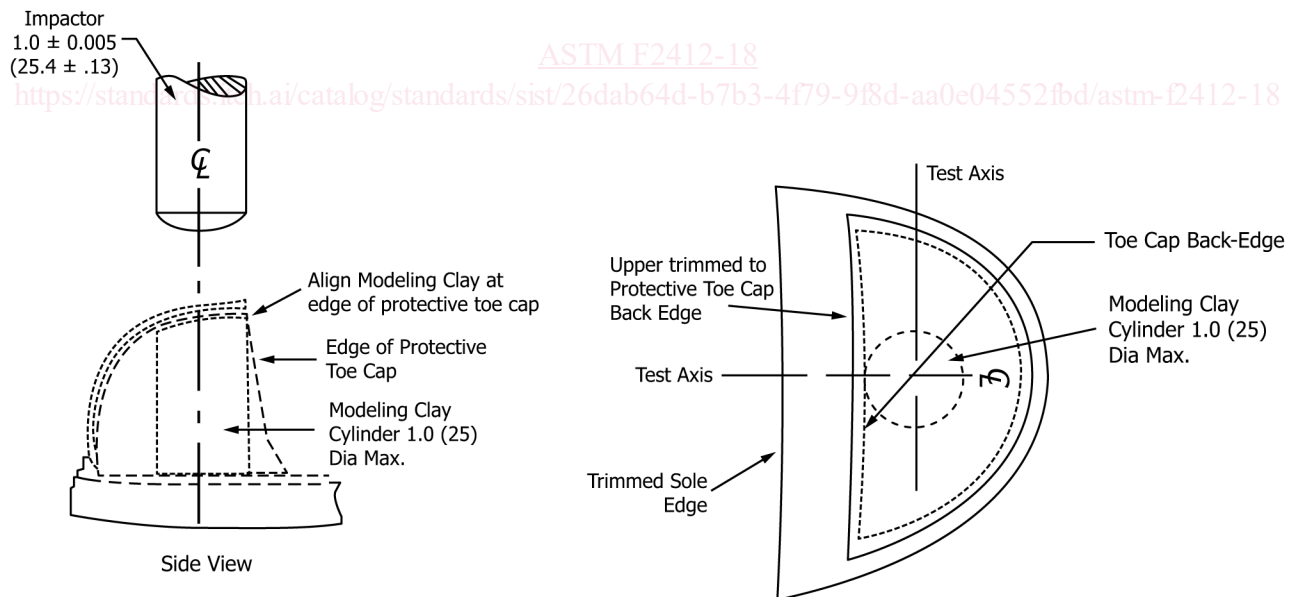

FIG. 3 Specimen Prepared for Impact and Compression Testing

5.4.5 A block having nominal dimensions of 75 by 75 by 44 mm (3 by 3 by 1.75 in.), with a hole drilled in the center of the block that is 25 mm (1 in.) in diameter and 25 mm (1 in.) deep, is slipped onto the impact nose.

5.4.6 The block/impactor assembly is carefully lowered until the wooden block makes contact with the modeling clay cylinder.

5.4.7 The impactor assembly is released allowing full weight to compress the cylinder for $\pm 0.5 \pm 1$ s.

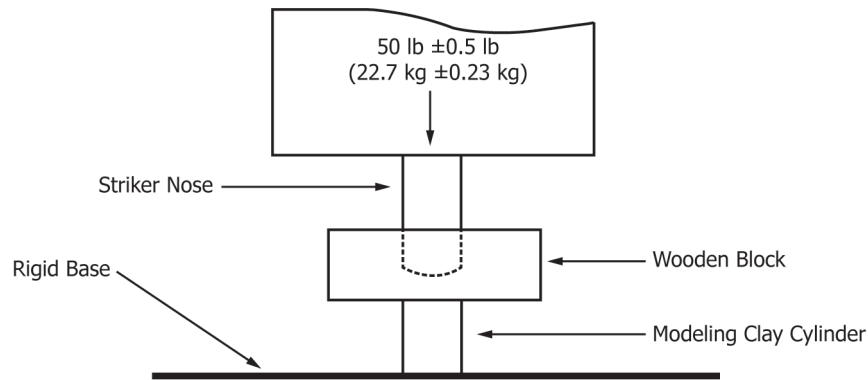

FIG. 4 Apparatus for Modeling Clay Quality Test

5.4.8 Immediately afterwards, the impactor assembly is raised and the modeling clay cylinder if necessary cut in half to measure.

5.4.9 A modeling clay cylinder having a compressed thickness of 15 ± 2 mm is acceptable to use in impact resistance.

5.5 *Specimen Mounting:*

5.5.1 Specimens are to be placed on the test apparatus base plate so that the sole is parallel with the base.

5.5.1.1 The specimen is positioned so that the longitudinal center of the nose of the impactor strikes the approximate center of the protective toe cap at a point that is 12.7 ± 1.6 mm (0.50 ± 0.0625 in.) toward the front as measured from the back edge of the protective toe cap (see Fig. 3).

5.5.2 The specimen is held in position during test by use of a clamping device as shown in Fig. 5.

5.5.2.1 The stabilizing fork clamp device rests on the insert and can be adjusted by means of a screw.

5.5.2.2 The adjustment secures the specimen parallel to the base plate and prevents movement when the impactor strikes the specimen.

5.5.2.3 Clamping screw shall be tightened using a force ~~less than 2.8~~ of 2.8 Nm (25 in. lbs).

5.6 *Procedure:*

5.6.1 When in place, the modeling clay cylinder shall be shaped having a base diameter of approximately 25 mm (1 in.) nominal and positioned so that the cylinder ~~simultaneously~~ makes contact with the insert/sock liner/footbed of the footwear and the dome of the protective toe cap. (See Note 1.)

NOTE 1—A small piece of release paper such as wax paper or cellophane can be placed on either the bottom side or top side of the clay cylinder to prevent the modeling clay from adhering to either the insert/sock liner or dome.

5.6.2 To measure Impact 75 product footwear, the impactor is dropped from a height that results in an impact velocity of 2995 ± 61 mm/s (117.9 ± 2.4 in./s), creating an energy of 101.75 J (~~75 ft-lbf~~ 101.75 J).

NOTE 2—In a vacuum, the distance would be 457 mm (18 in.). Due to friction and air resistance, the height used for the test is somewhat greater.

5.6.3 Release the impactor.

5.6.4 After impact raise and secure the impactor on test apparatus, carefully remove the clay cylinder from inside the specimen and measure the height of the modeling clay cylinder at its lowest point using a measuring device capable of measuring to the nearest 0.1 mm (0.004 in.).

5.6.5 This value is reported as the impact minimum interior height clearance for the specimen.

5.7 *Test Report*—Report the minimum height of the modeling clay cylinder, without rounding up, to the nearest 0.1 mm (0.004 in.) as the clearance result for the product category for all three specimens.

6. **Protective Toe Compression Resistance (C)**

6.1 *Summary of Method:*

6.1.1 Footwear shall be constructed and manufactured so that a protective toe cap is an integral and permanent part of the footwear.

6.1.2 Footwear with a protective toe cap is exposed to a compressive force.

6.1.3 During application of the compressive force, the interior space of the toe cap is measured using a modeling clay cylinder.

6.2 *Apparatus:*

6.2.1 Compression testing equipment that is equipped with smooth steel compression test surfaces.

6.2.1.1 Test surfaces must remain parallel during application of force up to ~~44 48222 241 N~~ (10 000 ~~5000~~ lbf).

6.2.1.2 Pressure head has a minimum diameter of 76.2 mm (3 in.) and a bed plate with a minimum width of 152.4 mm (6 in.).

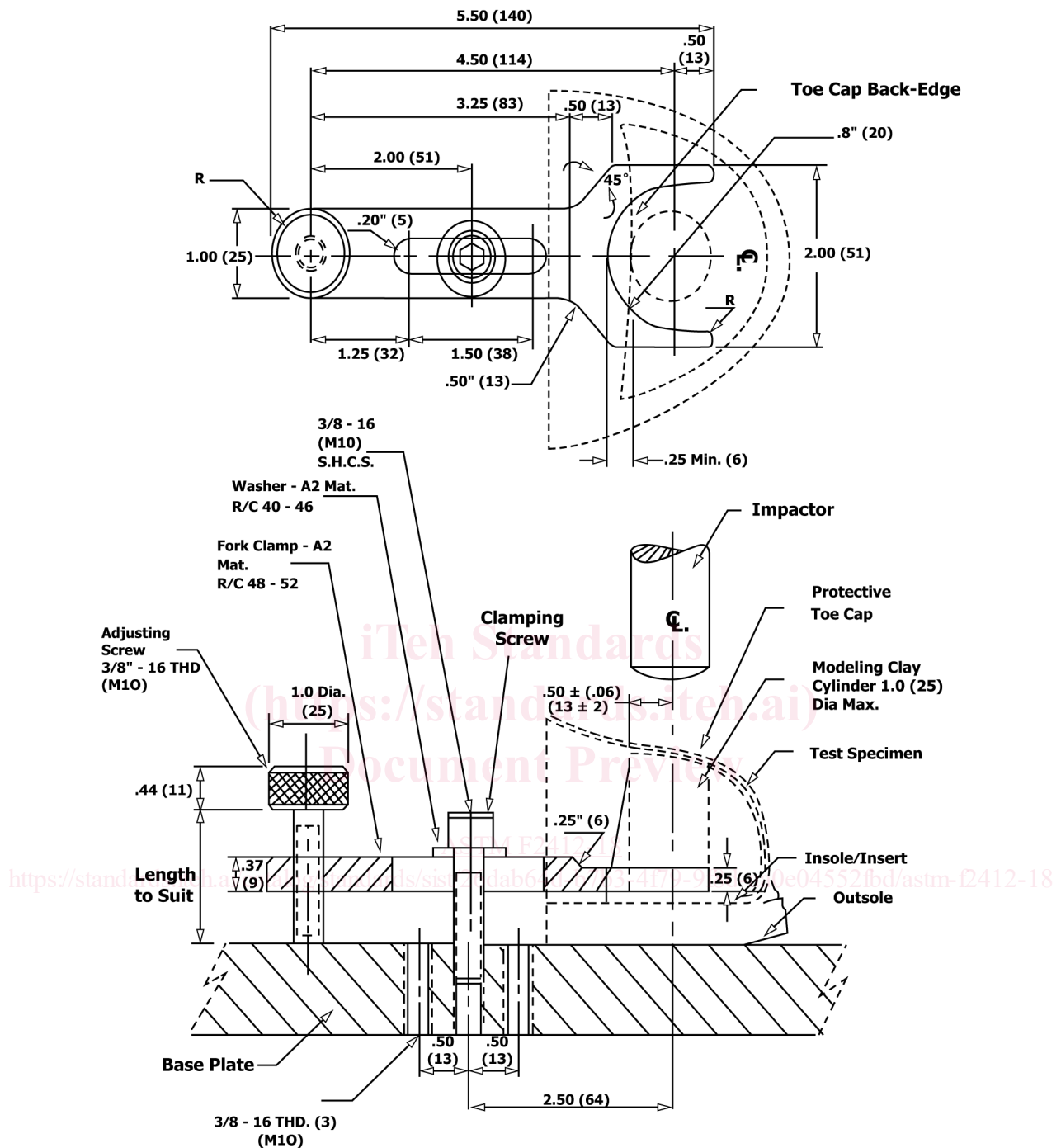

NOTE 1—Dimensions are in inches (millimetres).
FIG. 5 Position/Clamping/Impact Arrangement

6.2.1.3 Equipment must be graduated in increments so as to measure compressive force between 222.4 N (50 lbf) to 4448.222 241 N (10 000(5000 lbf).

6.3 Sampling:

6.3.1 Randomly select three half-pair test specimens, including both left and right footwear, of each product category from unworn manufactured footwear. If footwear is manufactured with a removable sockliner (footbed) the test is to be performed with the sockliner in place. All testing must be performed at standard conditions of 22°C (±2°C) and 50 % RH (±5 %).

6.3.1.1 Men’s footwear specimens shall be obtained from size 9.

6.3.1.2 Women’s footwear specimens shall be obtained from size 8.

6.3.2 The specimens shall be prepared by completely removing the toe portion of the footwear. This is done by cutting across the width of the footwear 25.4 ± 3.2 mm (1 ± 0.125 in.) behind the back edge of the protective toe cap and cutting the upper material back to the edge of the protective toe cap as shown in Fig. 2.

6.4 Prior to compression testing, modeling clay, kept at room temperature standard conditions and formed approximately as a 1 in. diameter vertical cylinder, shall be placed under the protective toe cap positioned inside the specimens directly under the point of impact compression (see Fig. 3) with the edge of the clay cylinder aligned with the back edge of the toe cap.

6.4.1 Modeling clay for the test forms shall be stored in a sealed container at standard conditions and tested in accordance with 6.4.25.4.2 – 6.4.95.4.9. Test frequency shall be no less than once every 6 months-month. Or sooner, if the color or consistency changes. It is recommended that this quality test be conducted on a specimen the clay just prior to its use during an impact compression test (see Fig. 4).

6.4.2 Weigh out a 50 ± 2 g sample of modeling clay.

6.4.3 Form material into a 35 ± 2 mm (1.375 ± 0.075 in.) cylinder and allow material to sit at room temperature for 24 h.

6.4.4 The modeling clay cylinder shall be placed horizontally on the base plate at the center point of the impact tester.

6.4.5 A block having dimensions of 75 by 75 by 44 mm (3 by 3 by 1.75 in.), with a hole drilled in the center of the block that is 25 mm (1 in.) in diameter and 25 mm (1 in.) deep, is slipped onto the impact nose.

6.4.6 The block/impactor assembly is carefully lowered until the block makes contact with the modeling clay cylinder.

6.4.7 The impactor assembly is released allowing full weight to compress the modeling clay cylinder for 10 s.

6.4.8 Immediately afterwards, the impactor assembly is raised and the modeling clay cylinder cut in half to measure.

6.4.9 A modeling clay cylinder having a compressed thickness of 15 ± 2 mm is acceptable to use in impact resistance.

6.5 Specimen Mounting:

6.5.1 The specimen is positioned on the bed plate of the test apparatus so that the highest point of the protective toe cap is perpendicular to the direction of force.

6.5.2 The stabilizing fork clamp device rests on the insert and can be adjusted by means of a screw (see Fig. 5).

6.5.2.1 This adjustment secures the specimen parallel to the bed plate and prevents movement.

6.5.2.2 Clamping screw shall be tightened using a force less than 28 of 2.8 Nm (25 in. lbs).

6.6 Procedure:

6.6.1 When in place, the modeling clay cylinder shall be shaped having a base diameter of approximately 25 mm (1 in.) nominal and positioned so that the cylinder simultaneously makes contact with the insert/sock liner/footbed of the footwear and the dome of the protective toe cap. (See Note 1 and Fig. 3.)

6.6.2 A compressive force is applied to the specimen at an approximate rate of 222.4 N/s (50 lbf/s) until it reaches 11 121 N (2500 ~~lb~~lbf) for Compression 75.

6.6.3 After compression testing, carefully remove the modeling clay cylinder from the specimen and, using a measuring device capable of measuring to the nearest 0.1 mm (0.004 in.) measure the height of the modeling clay cylinder at its lowest point, without rounding up. standards.iteh.ai/catalog/standards/sist/26dab64d-b7b3-4f79-9f8d-aa0e04552fbd/astm-f2412-18

6.7 Test Report—Report the minimum height of the modeling clay cylinder without rounding up to the nearest 0.1 mm (0.004 in.) as the clearance result for the product category for all three specimens.

7. Metatarsal Impact Resistance (Mt)

7.1 Summary of Method:

7.1.1 Footwear shall be constructed and manufactured so that a metatarsal impact guard is positioned partially over the protective toe cap and extended to cover the metatarsal bone area. The metatarsal protection shall be an integral and permanent part of the footwear.

7.1.2 Footwear with a protective toe cap and metatarsal guard is impacted with the appropriate force.

7.1.3 After impact, carefully remove the wax form from inside the footwear and measure.

7.2 Apparatus:

7.2.1 The same apparatus as used in 5.2 (Fig. 1) for impact testing of protective footwear, with certain modifications, is used for metatarsal impact testing. The modifications to the apparatus are shown in Fig. 6 and Fig. 6(a) and Fig. 7.

7.2.1.1 The striking surface that impacts the metatarsal protection is a horizontal bar that is perpendicular to the vertical traverse of the test apparatus. The bar of polished steel has bar is a solid steel cylinder having a diameter of $25.4 \pm 0.50.8$ mm ($1 \pm 0.020.03$ in.) and a length of 152.4 ± 3.2 mm ($6(6.0 \pm 0.1250.13$ in.).

7.2.1.2 The striking bar is positioned so that the impact is perpendicular to the longitudinal plane of the heel/toe axis at the appropriate impact point for men's and women's footwear (see Fig. 8).

7.3 Sampling:

7.3.1 Randomly select three half-pair test specimens, including both left and right footwear, of each product category from unworn manufactured footwear. If footwear is manufactured with a removable sockliner (footbed) the test is to be performed with the sockliner in place. All testing must be performed at standard conditions of $22^{\circ}\text{C} (\pm 2^{\circ}\text{C})$ and $50\% \text{ RH} (\pm 5\%)$.

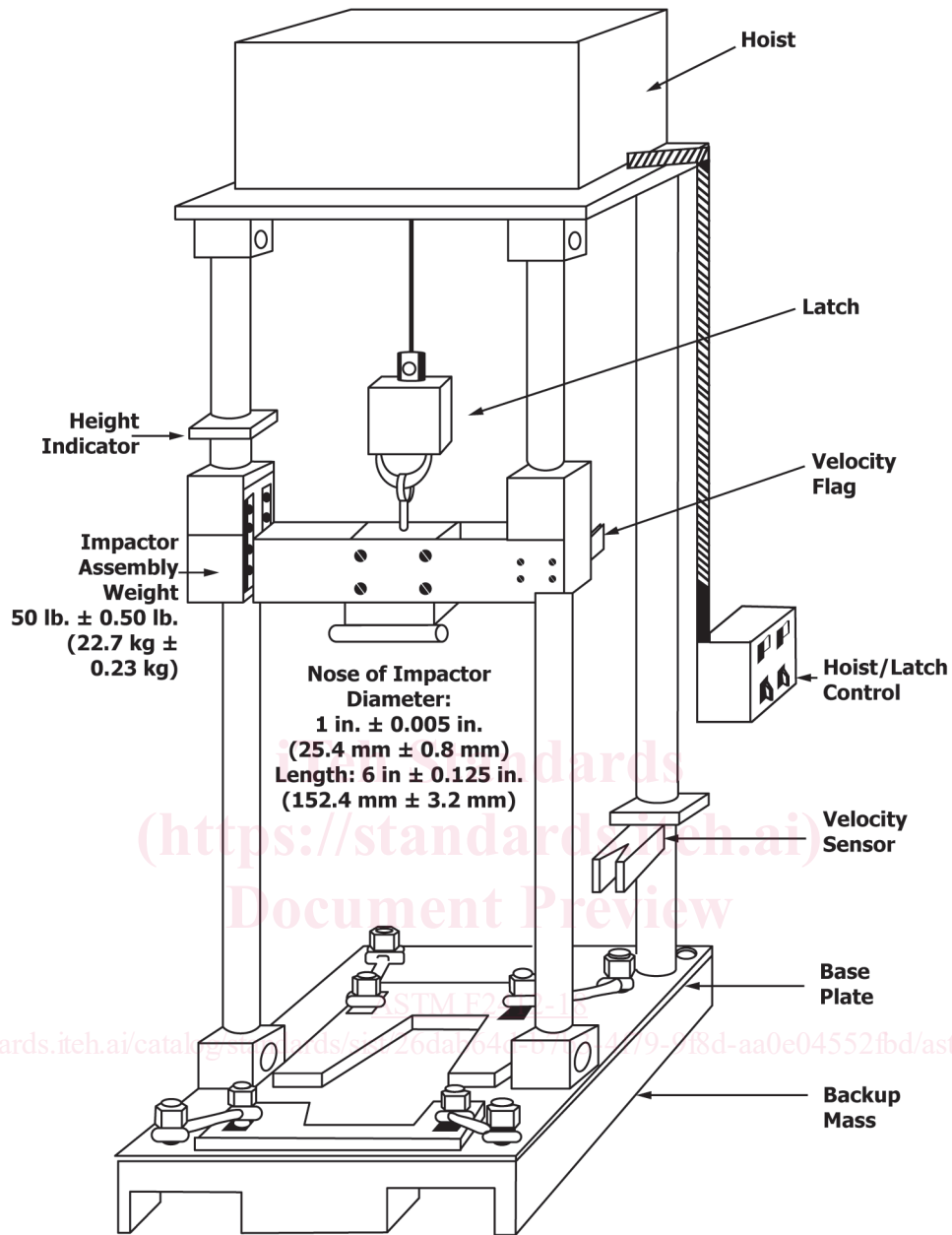

NOTE 1—Dimensions are in inches (millimetres).(millimeters).

FIG. 6 Metatarsal Footwear Impact Test Apparatus

7.3.1.1 Men's footwear specimens shall be obtained from size 9.

7.3.1.2 Women's footwear specimens shall be obtained from size 8.

7.4 Specimen Mounting:

7.4.1 Mount specimen in a device, as shown in Fig. 7, that retains footwear in place during testing.

7.4.2 Mount specimen so that outsole is resting on base of apparatus and positioned so that the point of contact for the striking bar is appropriate for the specimen as shown in Fig. 8.

7.4.2.1 Men's footwear requires that the point of contact for the striking bar is 89 mm (3.5 in.) when measured backwards from the front part of the toe toward the heel. As shown in Fig. 8.

7.4.2.2 Women's footwear requires that the point of contact for the striking bar is 86 mm (3.375 in.) when measured backwards from the front part of the toe toward the heel.

7.5 Procedure:

7.5.1 Insert a wax form, as described in Annex A1, into the specimen. The insert/sock lining/footbed of the footwear shall remain in the footwear during testing.



FIG. 6 (a) Metatarsal Impact Testing⁴ (continued)

7.5.1.1 The wax form shall completely fill the protective footwear cavity and extend toward the quarter of the footwear approximately 76.2 mm (3 in.) beyond the back edge of the protective toe cap. (See Fig. 8.)

7.5.1.2 The use of a heel block is used to secure the wax form in place and also to fill the cavity between the back edge of the wax form and the quarter.

7.5.2 To measure ~~Metatarsal Impact~~ 75 metarsal impact product footwear, the impactor is dropped from a height that results in an impact velocity of 2995 ± 61 mm/s (117.9 ± 2.4 in./s), creating an energy of 101.75 J (75 ft-lbf). ~~a height that results in an impact see-lbf).~~ **Note 3:**

NOTE 3—In a vacuum, the distance would be 457 mm (18 in.). Due to friction and air resistance, the height used for the test is somewhat greater.

7.5.2.1 Release the impactor,

7.5.3 After impact raise and secure the impactor on test apparatus, and carefully remove the wax form from the specimen.

7.5.4 *Test Report*—Measure the distance from the lowest point of the impression made in the wax form to the bottom surface of the form as shown in Fig. 8 and report the results to the nearest 0.1 mm (0.004 in.) for all three test specimens without rounding up.

8. Conductive Protective Footwear (Cd)

8.1 *Summary of Method:*

8.1.1 The footwear is placed on a base electrode plate and the second electrode is embedded in a layer of metal spheres which fill the inside of the footwear.

8.1.2 Electrical resistance is measured after applying the specified voltage for a prescribed time.

8.2 *Apparatus:*

8.2.1 The apparatus as shown in Fig. 9 requires that it be as follows:

8.2.1.1 500 V regulated dc power supply with a current rating of 5 mA or greater.

8.2.1.2 100 000 Ω resistor with accuracy $\pm 10\%$ rated at 2.5 W and 500 V or greater.

8.2.1.3 0 to 5 mA ammeter with accuracy of $\pm 5\%$ in one or more ranges.

8.2.1.4 Voltmeter of 0 to 500 V with minimum accuracy of $\pm 5\%$ in one or more ranges with a nominal internal resistance of 10 Megohm or greater.

8.2.1.5 A stainless steel base electrode plate ~~228.6 by 330.2~~ 228 by 330 ± 25 mm (9 by 13 ± 1 in.) that can accommodate the complete outsole and heel of the footwear. The second electrode consists of 3 to 5 mm (~~0.117(0.12 to 0.197)0.20 in.)~~ solid conductive metal spheres, which are placed inside the footwear to be tested so that the entire interior surface of the footwear is covered and reaches a depth of not less than 30 mm (~~1.18(1.2 in.)~~).

8.2.1.6 Because the conductive metal spheres do degrade with repeated use and handling they most likely will oxidize or become dirty and should be replaced with new conductive metal spheres. ~~spheres based on visual inspection as needed.~~

8.2.2 The electrical circuit connects power supply in series with the resistor, ammeter, electrodes, and test specimen. The volt meter is connected to the two electrodes to measure the voltage across the specimen.

8.2.2.1 Resistance is calculated using ohms law:

$$R = V/I \quad (2)$$

$$V = IR \quad (2)$$

where:

R = resistance calculated in ohms,