



SLOVENSKI STANDARD
SIST ISO 4190-2:1997
01-avgust-1997

Dvigala (lifti) - 2. del: Dvigala razreda IV

Passenger lifts and service lifts -- Part 2: Lifts of class IV

Ascenseurs et monte-charge -- Partie 2: Ascenseurs de classe IV

Ta slovenski standard je istoveten z: **ISO 4190-2:1982**

[SIST ISO 4190-2:1997](https://standards.iteh.ai/catalog/standards/sist/2ffd83c4-8eba-4b5e-ab2e-2cd85e0fba29/sist-iso-4190-2-1997)

<https://standards.iteh.ai/catalog/standards/sist/2ffd83c4-8eba-4b5e-ab2e-2cd85e0fba29/sist-iso-4190-2-1997>

ICS:

91.140.90 Öçã aãV^[^Áq] } &^ Lifts. Escalators

SIST ISO 4190-2:1997

en

iTeh STANDARD PREVIEW
(standards.iteh.ai)

SIST ISO 4190-2:1997

<https://standards.iteh.ai/catalog/standards/sist/2ffd83c4-8eba-4b5e-ab2e-2cd85e0fba29/sist-iso-4190-2-1997>

International Standard



4190/2

INTERNATIONAL ORGANIZATION FOR STANDARDIZATION • МЕЖДУНАРОДНАЯ ОРГАНИЗАЦИЯ ПО СТАНДАРТИЗАЦИИ • ORGANISATION INTERNATIONALE DE NORMALISATION

**Passenger lifts and service lifts —
Part 2 : Lifts of class IV**

Ascenseurs et monte-charge — Partie 2 : Ascenseurs de classe IV

First edition — 1982-12-01

iTeh STANDARD PREVIEW
(standards.iteh.ai)

SIST ISO 4190-2:1997

<https://standards.iteh.ai/catalog/standards/sist/2ffd83c4-8eba-4b5e-ab2e-2cd85e0fba29/sist-iso-4190-2-1997>

UDC 621.876.113

Ref. No. ISO 4190/2-1982 (E)

Descriptors : lifts, dimensions, characteristics.

Foreword

ISO (the International Organization for Standardization) is a worldwide federation of national standards institutes (ISO member bodies). The work of developing International Standards is carried out through ISO technical committees. Every member body interested in a subject for which a technical committee has been set up has the right to be represented on that committee. International organizations, governmental and non-governmental, in liaison with ISO, also take part in the work.

Draft International Standards adopted by the technical committees are circulated to the member bodies for approval before their acceptance as International Standards by the ISO Council.

International Standard ISO 4190/2 was developed by Technical Committee ISO/TC 178, *Lifts, escalators and passenger conveyors*, and was circulated to the member bodies in March 1981.

It has been approved by the member bodies of the following countries:

Austria	Hungary	Spain
Belgium	Ireland	Sweden
Brazil	Italy	Switzerland
Czechoslovakia	Netherlands	Thailand
Egypt, Arab Rep. of	Poland	USSR
Finland	Romania	Venezuela
France	South Africa, Rep. of	

The member bodies of the following countries expressed disapproval of the document on technical grounds :

Canada
Denmark
United Kingdom
USA

Passenger lifts and service lifts — Part 2 : Lifts of class IV

1 Scope and field of application

1.1 This part of ISO 4190 lays down the dimensions necessary to permit the installation of lifts of class IV, as defined in clause 3, generally used in industry for the transport of goods.

1.2 It deals more specifically with electric lifts. However, the horizontal dimensions of the wells specified for these lifts permit the installation of hydraulic lifts with the same car and door dimensions.

For the other characteristics, the manufacturers should be consulted.

1.3 This part of ISO 4190 applies to new lift installations with a car with one entrance, to be installed in a new building. Where relevant, it may be used as a basis for an installation in an existing building.

2 Reference

ISO 4190/1, *Passenger lift installation — Part 1 : Lifts of classes I, II and III.*

3 Definitions

For the purposes of this part of ISO 4190, the definitions given in ISO 4190/1, from which the following definition is repeated as an *aide-memoire*, are applicable.

lifts of class IV : Lifts designed mainly for the transport of goods which are generally accompanied by persons.

4 Characteristics

Lifts of class IV recommended for current uses shall have the following characteristics :

rated load (mass), in kilograms : 630 — 1 000 — 1 600 — 2 000

rated speed, in metres per second : 0,40 — 0,63 — 1,00.

5 Dimensions

5.1 Car

See the table and figures 1 and 2.

5.2 Well

See the table and figures 1 and 2.

The lift well plan dimensions specified are the minimum clear plumb sizes. The architect¹⁾, in agreement with the builder, shall ensure that adequate tolerances are added to the specified dimensions in the building design, so that these minimum plumb dimensions are satisfied when the work is finished. These dimensions only apply to lift installations in which the counterweight is guided by rigid metal guides.

In certain exceptional cases, the specified depths or widths may be insufficient when counterweight safety gear is provided.

1) Or any person assuming his functions.

ISO 4190/2-1982 (E)

Higher minimum values for the height above the highest level served may be required in certain countries to satisfy existing national regulations.

5.3 Distance between landings

The minimum distance necessary between two successive landings, to permit the installation of 2 100 mm high landing doors, shall be 2 550 mm.

5.4 Dimensions of the machine room

See the table and figure 1.

Greater machine room heights may be required in certain countries to satisfy existing national regulations.

5.5 Arrangement of the machine room

See figure 1.

The machine room shall be above the well.

The rear wall of the machine room shall be in line with the corresponding wall of the well and one of the lateral walls shall be in line with the corresponding wall of the well.

The lateral extension of the machine room with respect to the well (or common well) may be made either to the right or the left of the well.

The depth extension of the machine room with respect to the well shall be taken on the landing side.

Table — Standard electric lifts of class IV — Functional dimensions

Rated load (mass) ¹⁾	(kg)	630	1 000	1 600	2 000
Car	Width <i>A</i> (mm)	1 100	1 300	1 500	1 500
	Depth <i>B</i> (mm)	1 400	1 750	2 250	2 700
	Height (mm)	2 200	2 200	2 200	2 200
Car and landing doors	Width <i>E</i> (mm)	1 100	1 300	1 500	1 500
	Height <i>F</i> (mm)	2 100	2 100	2 100	2 100
Well	Width <i>C</i> (mm)	2 100	2 400	2 700	2 700
	Depth <i>D</i> (mm)	1 900	2 300	2 800	3 200
Pit	Depth <i>P</i> (mm)				
	$v_n \leq 1,0$ m/s	1 500	1 500	1 700	1 700
Height above the highest level served	<i>Q</i> (mm)				
	$v_n \leq 1,0$ m/s	4 100	4 100	4 300	4 300
Machine room	$v_n \leq 1,0$ m/s				
	Surface <i>S</i> (m ²)	12	14	18	20
	Width ²⁾ <i>R</i> (mm)	2 800	3 100	3 400	3 400
	Depth ²⁾ <i>T</i> (mm)	3 500	3 800	4 500	4 900
	Height <i>H</i> (mm)	2 200	2 200	2 400	2 400

1) Pending the establishment of an internationally agreed ratio of load to surface area of the lift car in national safety regulations, values of rated load somewhat different from those given above may be used in the meantime in countries where the load/surface area ratio is given in national standards.

2) The values given for *R* and *T* are minimum ones. The actual dimensions shall lead to an area equal to at least *S*.

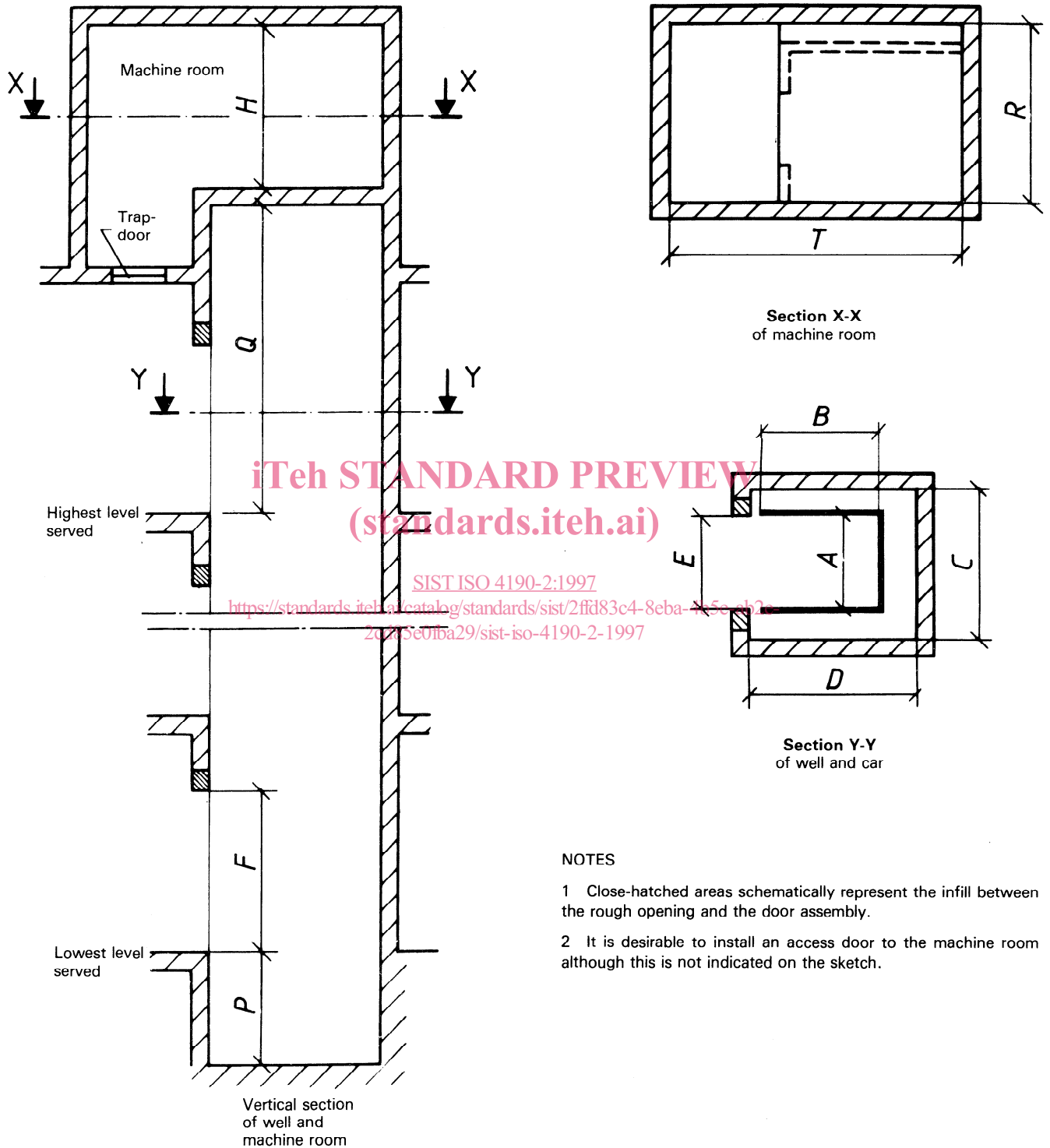
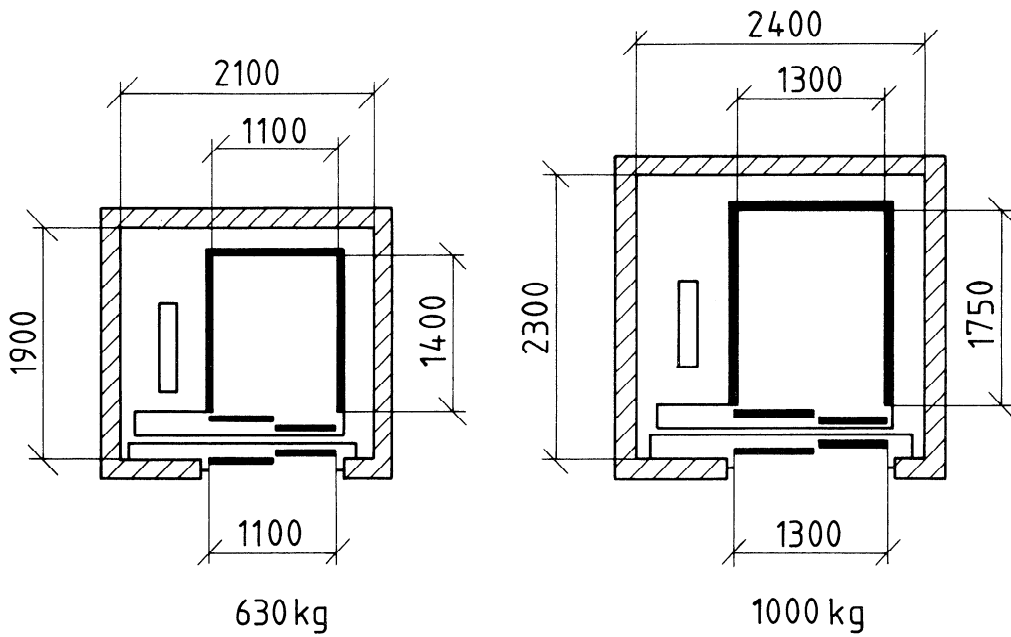
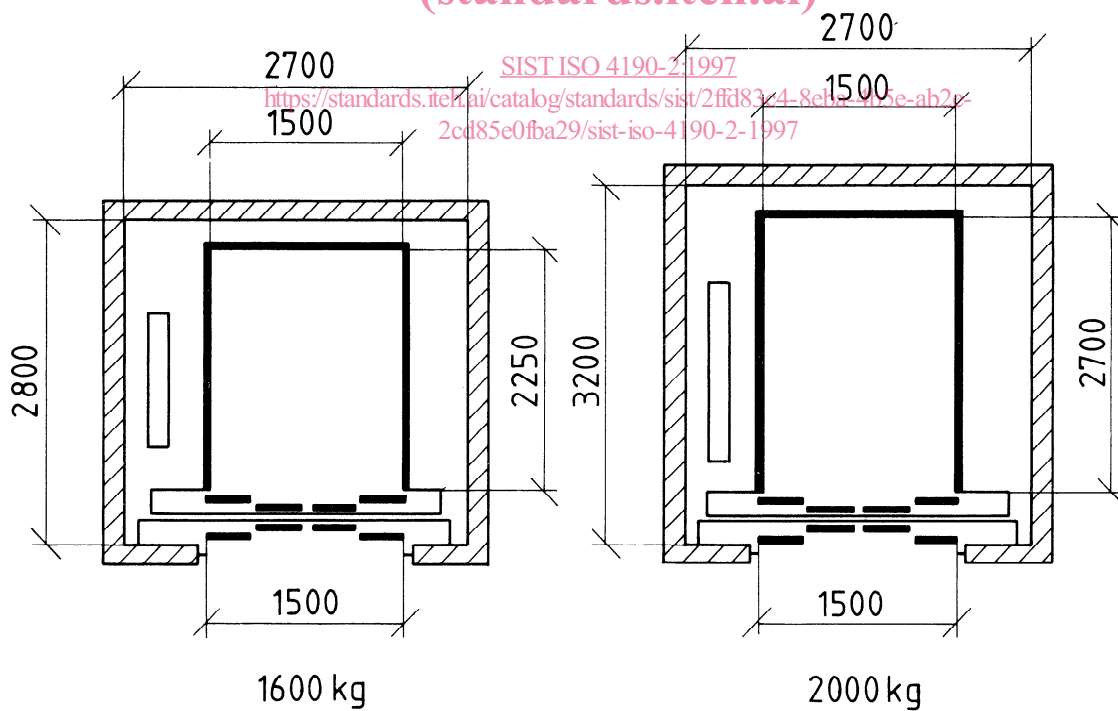

Figure 1

Dimensions in millimetres



iTeh STANDARD PREVIEW
(standards.iteh.ai)



Car height : 2 200
Clear entrance : 2 100

NOTE — Other types of doors can be used.

Figure 2