



SLOVENSKI STANDARD
SIST EN 13544-2:2003

01-marec-2003

8] U b U c d f Y a U n U n X f U j ` ^ b ^ Y ! ' & " X Y . ' 7 Y j _ Y] b ` d f] _ ` 1 _]

Respiratory therapy equipment - Part 2: Tubing and connectors

Atemtherapiegeräte - Teil 2: Schlauchsysteme und Verbindungsstücke

iTeh STANDARD PREVIEW

Equipement de thérapie respiratoire - Partie 2: Tubes et raccords

Ta slovenski standard je istoveten z: EN 13544-2:2002

SIST EN 13544-2:2003
<https://standards.iteh.ai/catalog/standards/sist/4cc12e6f-d676-48ea-9ac4-996a2138eeb6/sist-en-13544-2-2003>

ICS:

11.040.10	Anestezijska, respiratorna in reanimacijska oprema	Anaesthetic, respiratory and reanimation equipment
-----------	--	--

SIST EN 13544-2:2003

en

iTeh STANDARD PREVIEW
(standards.iteh.ai)

SIST EN 13544-2:2003

<https://standards.iteh.ai/catalog/standards/sist/4ccf2e6f-d676-48ea-9ac4-996a2138eeb6/sist-en-13544-2-2003>

EUROPEAN STANDARD
NORME EUROPÉENNE
EUROPÄISCHE NORM

EN 13544-2

October 2002

ICS 11.040.10

English version

Respiratory therapy equipment - Part 2: Tubing and connectors

Équipement de thérapie respiratoire - Partie 2: Tubes et raccords

Atemtherapiegeräte - Teil 2: Schlauchsysteme und Verbindungsstücke

This European Standard was approved by CEN on 1 August 2002.

CEN members are bound to comply with the CEN/CENELEC Internal Regulations which stipulate the conditions for giving this European Standard the status of a national standard without any alteration. Up-to-date lists and bibliographical references concerning such national standards may be obtained on application to the Management Centre or to any CEN member.

This European Standard exists in three official versions (English, French, German). A version in any other language made by translation under the responsibility of a CEN member into its own language and notified to the Management Centre has the same status as the official versions.

CEN members are the national standards bodies of Austria, Belgium, Czech Republic, Denmark, Finland, France, Germany, Greece, Iceland, Ireland, Italy, Luxembourg, Malta, Netherlands, Norway, Portugal, Spain, Sweden, Switzerland and United Kingdom.

STANDARD PREVIEW
(standards.iteh.ai)

SIST EN 13544-2:2003

<https://standards.iteh.ai/catalog/standards/sist/4ccf2e6f-d676-48ea-9ac4-996a2138eeb6/sist-en-13544-2-2003>



EUROPEAN COMMITTEE FOR STANDARDIZATION
COMITÉ EUROPÉEN DE NORMALISATION
EUROPÄISCHES KOMITEE FÜR NORMUNG

Management Centre: rue de Stassart, 36 B-1050 Brussels

EN 13544-2:2002 (E)

CONTENTS

	Page
Foreword.....	3
1 Scope	4
2 Normative references	4
3 Nipples	4
3.1 Dimensions.....	4
3.2 Performance	4
4 Weight-bearing screw-threaded connectors.....	4
5 Tubing	4
5.1 General.....	4
6 Marking of tubing, labels and packaging	7
7 Packaging	7
Annex A (normative) Test methods.....	8
A.1 Apparatus	8
A.2 Method of test for strength of nipple.....	8
A.3 Method of test for resistance to gas flow of tubing	11
A.4 Method of test for security of connection between end connector and tubing	12
A.5 Method of test for security of connection of end connectors and nipple.....	12
A.6 Method of test for resistance to kinking.....	13
Annex B (normative) Weight-bearing screw-threaded connectors for oxygen and air	15
Annex C (informative) Information on method of testing security of connections	16
Annex ZA (informative) Clauses of this European Standard addressing essential requirements or other provisions of EU Directives	17
Bibliography	18

Foreword

This document (EN13544-2:2002) has been prepared by Technical Committee CEN /TC 215, "Respiratory and anaesthetic equipment", the secretariat of which is held by BSI.

This European Standard shall be given the status of a national standard, either by publication of an identical text or by endorsement, at the latest by April 2003, and conflicting national standards shall be withdrawn at the latest by April 2003.

This European Standard has been prepared under a mandate given to CEN by the European Commission and the European Free Trade Association, and supports essential requirements of EU Directive(s).

Annexes A and B are normative. Annex C is informative.

For relationship with EU Directive(s), see informative annex ZA, which is an integral part of this document.

EN 13544 consists of the following parts, under the general title Respiratory therapy equipment.

Part 1: Nebulizing systems and their components

Part 2: Tubing and connectors

Part 3: Air entrainment devices

According to the CEN/CENELEC Internal Regulations, the national standards organizations of the following countries are bound to implement this European Standard: Austria, Belgium, Czech Republic, Denmark, Finland, France, Germany, Greece, Iceland, Ireland, Italy, Luxembourg, Malta, Netherlands, Norway, Portugal, Spain, Sweden, Switzerland and the United Kingdom.

<https://standards.cen.eu/catalog/standards/sist/4cc2e6f-d676-48ea-9ac4-996a2138eeb6/sist-en-13544-2-2003>

EN 13544-2:2002 (E)

1 Scope

This part of EN 13544 specifies requirements for tubing to be used with equipment for the therapeutic administration of respirable gases in domiciliary, ambulance and hospital practice including the interface to the equipment i.e. nipples and screw threaded connectors. This tubing is mainly used with oxygen, air or mixtures of these gases.

The interface specifications are given to ensure interchangeability of respiratory therapy equipment thereby enabling patients to receive continuous treatment in all these clinical situations.

Weight-bearing screw-threaded connectors are specified for use at the outlet of e.g. flowmeters to which devices such as humidifiers or nebulizers can be attached.

NOTE This standard does not specify the devices where these connectors have to be used. It is expected that specific device standards will specify the devices where these connectors are going to be used e.g. EN ISO 10651-4, EN 738-1 and EN 13220.

2 Normative references

This European Standard incorporates by dated or undated reference, provisions from other publications. These normative references are cited at the appropriate places in the text and the publications are listed hereafter. For dated references, subsequent amendments to or revisions of any of these publications apply to this European Standard only when incorporated in it by amendment or revision. For undated references the latest edition of the publication referred to applies (including amendments).

EN 980, *Graphical symbols for use in the labelling of medical devices.*

[SIST EN 13544-2:2003](https://standards.iteh.ai/catalog/standards/sist/4ccf2e6f-d676-48ea-9ac4-996a2138eeb6/sist-en-13544-2-2003)

3 Nipples

<https://standards.iteh.ai/catalog/standards/sist/4ccf2e6f-d676-48ea-9ac4-996a2138eeb6/sist-en-13544-2-2003>

3.1 Dimensions

The dimensions of nipples for the attachment of tubing to respiratory therapy equipment shall conform to the dimensions given in Figure 1 a), and also, if corrugated, shall conform to 1 b).

3.2 Performance

When tested as described in A.2, nipples shall neither fracture nor distort by more than 2 mm.

4 Weight-bearing screw-threaded connectors

4.1 Weight-bearing screw-threaded connectors for oxygen shall comply with Figure B.1.

4.2 Weight-bearing screw-threaded connectors for air shall comply with Figure B.2.

5 Tubing

5.1 General

Material used for tubing shall be :

- a) compatible with oxygen or air or any other gas mixture specified by the manufacturer ;
- b) non-toxic ;

- c) designed and manufactured to minimize health risks by leaching of substances from tubing during normal use to levels below those assumed to be non-toxic.

Evidence shall be provided by the manufacturer on request.

5.1.1 Resistance to gas flow of tubing

When tested as described in A.3, the resistance to flow shall not exceed 0,9 kPa/m.

5.1.2 End connectors

Tubing for respiratory therapy equipment shall terminate at each end with a connector able to produce a secure connection conforming to 5.1.4 to the nipple specified in clause 3.

NOTE Connectors can either be formed in the material of the tubing or can be joined to the tubing by e.g. welding or adhesives.

iTeh STANDARD PREVIEW
(standards.iteh.ai)

[SIST EN 13544-2:2003](https://standards.iteh.ai/catalog/standards/sist/4ccf2e6f-d676-48ea-9ac4-996a2138eeb6/sist-en-13544-2-2003)

<https://standards.iteh.ai/catalog/standards/sist/4ccf2e6f-d676-48ea-9ac4-996a2138eeb6/sist-en-13544-2-2003>

Dimensions in millimetres

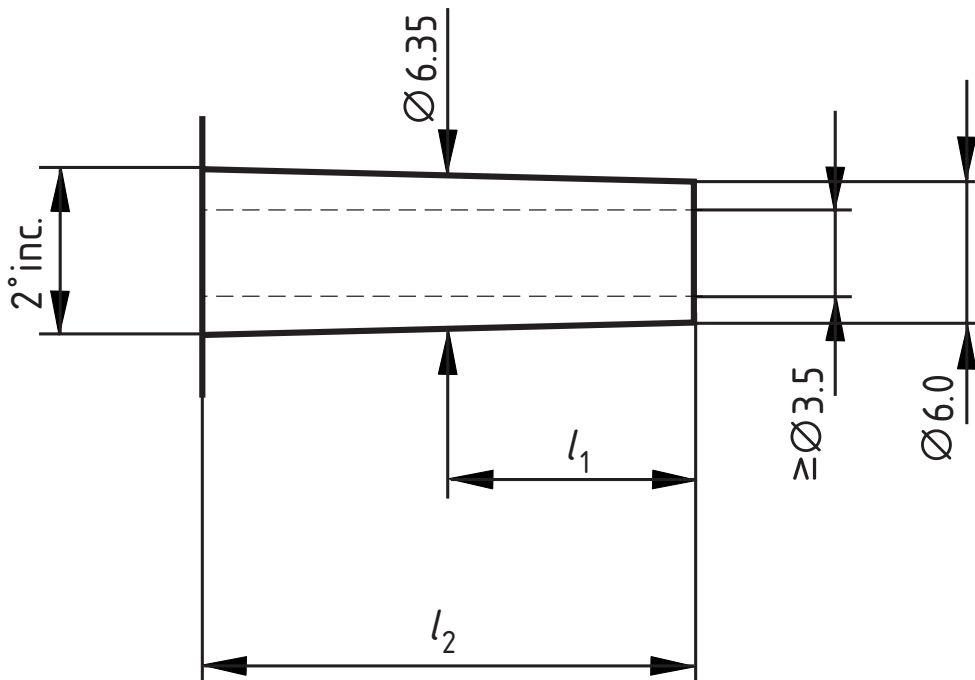

iTeh STANDARD PREVIEW
(standards.iteh.ai)

Key l_1 10 mm datum l_2 12 mm minimum to shoulder or projection

NOTE The axis of the nipple can be curved.

SIST EN 13544-2:2003

<https://standards.iteh.ai/catalog/standards/sist/4ccf2e6f-d676-48ea-9ac4-996a2138eeb6/sist-en-13544-2-2003>

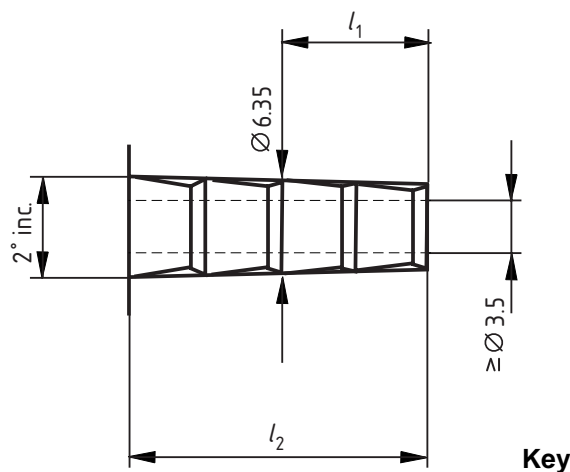
a) Basic profile and nominal dimensions of nipple**Key** l_1 10 mm datum with a minimum of two corrugations within this length l_2 12 mm minimum to shoulder or projection

NOTE The external diameter of all corrugations falls on the profile of the nipple as shown in 1a. The shape of the corrugations is given as an example.

b) Dimensions for corrugated nipple**Figure 1 — Nipple for respiratory therapy equipment**

5.1.3 Security of joint between end connector and tubing

When tested as described in A.4, if the end connector is joined to the tubing, the end connector shall not become detached from the tubing.

5.1.4 Security of connection of end connectors to nipple

When tested as described in A.5, heavy duty tubing shall not become detached from the test nipple.

NOTE See annex C for information on the method of testing the security of connection between an end connector and a nipple.

5.1.5 Resistance to kinking

When tested as described in A.6, the flow through the kinked tubing shall be not less than 75 % of the initial flow.

6 Marking of tubing, labels and packaging

Tubing, labels, and/or packaging shall contain the following as applicable :

- name and address of the manufacturer ;
- if the intended purpose of the device is not obvious to the operator, the device shall be provided with instructions for use ;
- device identification and content information ;
- symbol **STERILE** in accordance with EN 980 together with the method of sterilization ;
- batch code, preceded by the symbol **LOT** in accordance with EN 980, or serial number ;
- declaration of the maximum pressure the tubing shall withstand at ambient conditions specified in Table A.1 ;
- date by which the device can be used, expressed as the year and month ;
- indication that the device is for single use ;
- any special storage and/or handling conditions ;
- any warning and/or precaution to take ;
- recommended method(s) of cleaning, disinfection and sterilization ;
- device packaging and/or labelling shall differentiate between the same or similar products, both sterile and non-sterile, placed on the market by the same manufacturer ;
- packages containing parts made of antistatic or conductive material shall be clearly marked with the word "ANTISTATIC" or "CONDUCTIVE".

7 Packaging

The method of packaging should be designed to minimize the risk of kinking of the tubing occurring while in storage.

Annex A (normative)

Test methods

A.1 Apparatus

A.1.1 Tensile testing machine capable of applying a force of at least 30 N with an accuracy of $\pm 5\%$.

A.1.2 Test gas supply, comprising either dry compressed air or oxygen.

A.1.3 Equipment to control flow and pressure of the test gas supply to values of at least 10 l/min and 200 kPa respectively.

A.1.4 T-piece connector for gas pathway.

A.1.5 Equipment to measure ambient temperature and atmospheric pressure with an accuracy of $\pm 2\%$.

A.1.6 Pressure gauge(s) capable of measuring pressure with an accuracy of $\pm 5\%$.

A.1.7 Test nipple with construction and dimensions as shown in Figure A.1.

A.1.8 Equipment for testing security of connection of termination to nipple as exemplified in figure A.2.

NOTE Other methods of force application are acceptable.

A.1.9 Equipment for testing resistance to kinking as shown in Figure A.3.

A.1.10 Flowmeter to measure flows of air between 4 l/min and 10 l/min with an accuracy of $\pm 5\%$.

A.1.11 Two tubular spacers, outside diameter 12 mm minimum and inside diameter $(6,5 \pm 0,05)$ mm, and of lengths as follows :

— spacer a : $(10,0 \pm 0,1)$ mm ;

— spacer b : $(8,0 \pm 0,1)$ mm.

A.2 Method of test for strength of nipple

A.2.1 Test conditions

If the nipple is to be attached to, or forms part of, a device which is intended to operate at elevated temperature, perform the test at the maximum operating temperature of the device if stated by the manufacturer, or otherwise at (45 ± 2) °C.

A.2.2 Procedure

Securely fix the equipment end of the nipple and apply, using the tensile testing machine (A.1.1), a force at right angles to the axis of the nipple at a point not more than 2 mm from the distal end, increasing the force from zero to $(10 \pm 0,1)$ N over a period of between 0,1 s and 1 s. Maintain the force for 60 s.

Record if the nipple fractures. If it does not, record the amount by which the nipple distorts at right angles to its axis at the distal end to the nearest 0,2 mm.

Remove the force.

Dimensions in millimetres

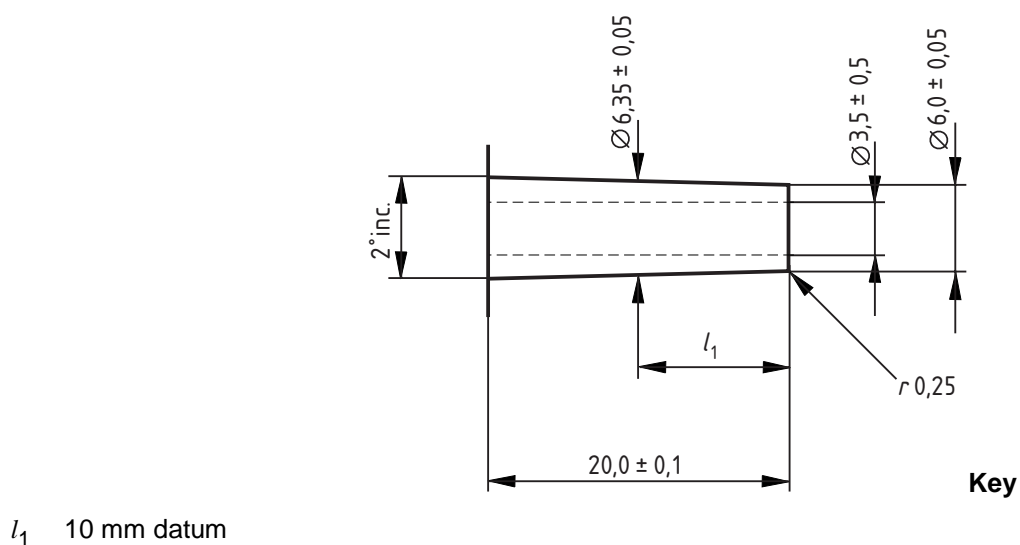

l_1 10 mm datum

Figure A.1 — Test nipple made in stainless steel : fine-ground finish N6

iTeh STANDARD PREVIEW
(standards.iteh.ai)

SIST EN 13544-2:2003

<https://standards.iteh.ai/catalog/standards/sist/4ccf2e6f-d676-48ea-9ac4-996a2138eeb6/sist-en-13544-2-2003>