



Designation: E235/E235M – 12 (Reapproved 2018)

Standard Specification for Type K and Type N Mineral-Insulated, Metal-Sheathed Thermocouples for Nuclear or for Other High-Reliability Applications¹

This standard is issued under the fixed designation E235/E235M; the number immediately following the designation indicates the year of original adoption or, in the case of revision, the year of last revision. A number in parentheses indicates the year of last reapproval. A superscript epsilon (ϵ) indicates an editorial change since the last revision or reapproval.

1. Scope

1.1 This specification covers the requirements for simplex, compacted mineral-insulated, metal-sheathed (MIMS), Type K and N thermocouples for nuclear or other high reliability service. Depending on size, these thermocouples are normally suitable for operating temperatures to 1652°F [900°C]; special conditions of environment and life expectancy may permit their use at temperatures in excess of 2012°F [1100°C]. This specification was prepared to detail requirements for this type of MIMS thermocouple for use in nuclear environments, but they can also be used for laboratory or general commercial applications where the environmental conditions exceed normal service requirements. The intended use of a MIMS thermocouple in a specific nuclear application will require evaluation of the compatibility of the thermocouple, including the effect of the temperature, atmosphere, and integrated neutron flux on the materials and accuracy of the thermoelements in the proposed application by the purchaser.

1.2 This specification does not attempt to include all possible specifications, standards, etc., for materials that may be used as sheathing, insulation, and thermocouple wires for sheathed-type construction. The requirements of this specification include only the austenitic stainless steels and other alloys as allowed by Specification E585/E585M for sheathing, magnesium oxide or aluminum oxide as insulation, and Type K and N thermocouple wires for thermoelements (see Note 1).

1.3 *General Design*—Nominal sizes of the finished thermocouples shall be 0.0400 in., 0.0625 in., 0.125 in., 0.1875 in., or 0.250 in. [1.000 mm, 1.500 mm, 3.000 mm, 4.500 mm, or 6.000 mm]. Sheath dimensions and tolerances for each nominal size shall be in accordance with Table 1 and Figs. 1 and 2. The measuring junction styles for thermocouples covered by this specification are as follows:

1.3.1 *Style G² (grounded)*—The measuring junction is electrically connected to its conductive sheath, and

1.3.2 *Style U² (ungrounded)*—The measuring junction is electrically isolated from its conductive sheath and from reference ground.

1.4 The values stated in either SI units or inch-pound units are to be regarded separately as standard. The values stated in each system are not exact equivalents or conversions; therefore, each system shall be used independently of the other. Combining values from the two systems may result in non-conformance with the standard.

1.5 *This standard does not purport to address all of the safety concerns, if any, associated with its use. It is the responsibility of the user of this standard to establish appropriate safety, health, and environmental practices and determine the applicability of regulatory limitations prior to use.*

1.6 *This international standard was developed in accordance with internationally recognized principles on standardization established in the Decision on Principles for the Development of International Standards, Guides and Recommendations issued by the World Trade Organization Technical Barriers to Trade (TBT) Committee.*

2. Referenced Documents

2.1 ASTM Standards:³

A262 Practices for Detecting Susceptibility to Intergranular Attack in Austenitic Stainless Steels

E3 Guide for Preparation of Metallographic Specimens

E45 Test Methods for Determining the Inclusion Content of Steel

E112 Test Methods for Determining Average Grain Size

E165 Practice for Liquid Penetrant Examination for General Industry

E220 Test Method for Calibration of Thermocouples By

¹ This specification is under the jurisdiction of ASTM Committee E20 on Temperature Measurement and is the direct responsibility of Subcommittee E20.12 on Thermocouples - Specifications.

Current edition approved April 1, 2018. Published April 2018. Originally approved in 1964. Last previous edition approved in 2012 as E235/E235M – 12. DOI: 10.1520/E0235-12R18.

² Style G and Style U measuring junctions were previously termed Class 1 and Class 2 measuring junctions respectively.

³ For referenced ASTM standards, visit the ASTM website, www.astm.org, or contact ASTM Customer Service at service@astm.org. For *Annual Book of ASTM Standards* volume information, refer to the standard's Document Summary page on the ASTM website.

TABLE 1 Dimensions for Style G and U Measuring Junctions

Sheath Outside Diameter, A			Minimum Sheath Wall, B	Minimum Insulation Thickness, C	Minimum Wire Diameter, D	E, Tolerance		F, Tolerance	
Nominal	Tolerance					min	max	min	max
	min	max							
Inches									
0.0400	0.0390	0.0415	0.006	0.004	0.005	0.006	0.020	0.004	0.021
0.0625	0.0615	0.0640	0.009	0.005	0.010	0.009	0.032	0.005	0.032
0.1250	0.1240	0.1265	0.012	0.012	0.020	0.012	0.062	0.012	0.063
0.1875	0.1865	0.1890	0.020	0.022	0.031	0.020	0.093	0.022	0.095
0.2500	0.2480	0.2520	0.030	0.024	0.040	0.030	0.125	0.024	0.125
[Millimetres]									
[1.000]	[0.975]	[1.038]	[0.15]	[0.10]	[0.13]	[0.15]	[0.51]	[0.10]	[0.53]
[1.500]	[1.475]	[1.538]	[0.23]	[0.13]	[0.25]	[0.23]	[0.81]	[0.13]	[0.81]
[3.000]	[2.975]	[3.038]	[0.30]	[0.30]	[0.51]	[0.30]	[1.57]	[0.30]	[1.60]
[4.500]	[4.475]	[4.538]	[0.51]	[0.56]	[0.79]	[0.51]	[2.36]	[0.56]	[2.41]
[6.000]	[5.950]	[6.050]	[0.76]	[0.61]	[1.02]	[0.76]	[3.18]	[0.61]	[3.18]

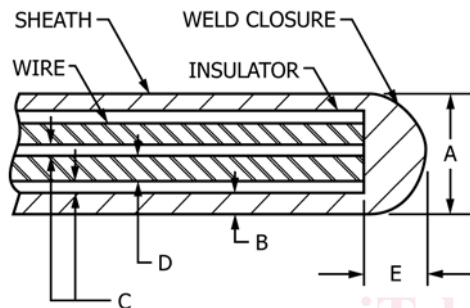

FIG. 1 Grounded Measuring Junction, Style G

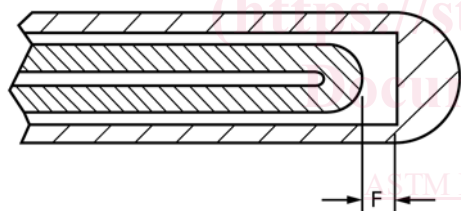

FIG. 2 Ungrounded Measuring Junction, Style U

Comparison Techniques

- E230 Specification and Temperature-Electromotive Force (EMF) Tables for Standardized Thermocouples
- E344 Terminology Relating to Thermometry and Hydrometry
- E585/E585M Specification for Compacted Mineral-Insulated, Metal-Sheathed, Base Metal Thermocouple Cable
- E780 Test Method for Measuring the Insulation Resistance of Mineral-Insulated, Metal-Sheathed Thermocouples and Mineral-Insulated, Metal-Sheathed Cable at Room Temperature
- E839 Test Methods for Sheathed Thermocouples and Sheathed Thermocouple Cable
- E883 Guide for Reflected-Light Photomicrography
- E1652 Specification for Magnesium Oxide and Aluminum Oxide Powder and Crushable Insulators Used in the Manufacture of Base Metal Thermocouples, Metal-Sheathed Platinum Resistance Thermometers, and Noble Metal Thermocouples

2.2 ANSI Standard:

B46.1 Surface Texture⁴

2.3 American Welding Society Standard:

A5.9 Specification for Corrosion-Resisting Chromium and Chromium-Nickel Steel-Welding Rods and Bare Electrodes⁵

3. Terminology

3.1 The definitions given in Terminology E344 shall apply to this specification.

3.2 Definitions of Terms Specific to This Standard:

3.2.1 lot, n—a quantity of finished MIMS thermocouples manufactured from the same lot of MIMS cable, then assembled and processed at the same time under the same controlled production conditions to their required final configuration.

4. Ordering Information and Basis of Purchase

4.1 The purchase order documents shall specify the following information:

- 4.1.1 The quantity, length, and nominal diameter of the MIMS thermocouple,
- 4.1.2 The thermocouple type and tolerance on the initial values of emf versus temperature per Table 2, if other than standard,
- 4.1.3 The type of ceramic insulation required, either alumina (Al₂O₃) or magnesia (MgO),
- 4.1.4 The type of sheath material and other information required (see 5.1.1),
- 4.1.5 The style of thermocouple measuring junction (see 1.2),
- 4.1.6 The type of dye-penetrant inspection procedure to be used, and
- 4.1.7 Any deviations from this specification or the referenced specifications.

5. Materials and Manufacture

5.1 All materials used shall be in accordance with the following requirements:

⁴ Available from American National Standards Institute (ANSI), 25 W. 43rd St., 4th Floor, New York, NY 10036, <http://www.ansi.org>.

⁵ Available from American Welding Society (AWS), 550 NW LeJeune Rd., Miami, FL 33126, <http://www.aws.org>.

TABLE 2 Tolerances on Initial Values of EMF versus Temperature for MIMS Thermocouples

NOTE 1—Tolerances in this table apply to new MIMS thermocouples.

NOTE 2—Tolerances apply to new material as produced and do not allow for changes in thermoelectric characteristics of the materials during use. The magnitude of such changes depends upon such factors as sheath and thermoelement size, temperature, time of exposure, and the environment.

NOTE 3—Where tolerances are given in percent, the percentage applies to the temperature being measured when expressed in degrees Celsius.

NOTE 4—To determine the tolerance in degrees Fahrenheit, multiply the tolerance in degrees Celsius by 9/5.

Thermocouple Type	Temperature Range		Tolerances—Reference Junction 32°F [0°C]			
	°F	[°C]	Standard Tolerances		Special Tolerances	
			°F	[°C]	°F	[°C]
K or N	32 to 2300	[0 to 1260]	Note 4	[The greater of ±2.2°C or ±0.75 %]	Note 4	[The greater of ±1.1°C or ±0.4 %]
K ^A	−328 to 32	[−200 to 0]		[The greater of ±2.2°C or ±2 %]		^B

^A MIMS the thermocouples are normally supplied to meet the tolerances specified in the table for temperatures above 0°C. The same materials, however, may not fall within the sub-zero tolerances given in the second section of the table. If materials are required to meet the sub-zero limits, the purchase order shall so state. Selection of materials shall be required.

^B Little information is available to justify establishing special tolerances for sub-zero temperatures. Such special sub-zero tolerances, if required, shall be agreed upon between the purchaser and the producer.

5.1.1 *Sheath Materials*—The sheath material used for the thermocouples described in this specification shall meet the requirements of Specification E585/E585M. The purchaser of the thermocouples shall specify only the name of the material (seamless or welded), grade, optional requirements, test report required, and ASTM designation.

5.1.1.1 The inclusion level of the sheath shall be determined by mounting a 1-in. minimum length of a longitudinal section of the sheath using Test Methods E45, Microscopical Method A, for examination. The inclusion level shall be less than 3 A through D, thin or heavy.

5.1.1.2 The grain size of the sheath shall be determined by a specimen taken in accordance with Test Methods E112. Grain size shall be as specified in Table 3, or finer, as determined by the Comparison Procedure of Test Methods E112.

5.1.1.3 Each lot of sheath material used shall be sampled using Practices A262 as follows. Samples shall be tested by Practice A, and further tested as outlined by Table 1 in Practices A262, where screening tests so indicate. Acceptance levels for these tests shall be agreed upon between the purchaser and the producer.

5.1.2 *Thermoelement*—Thermoelements referred to in this specification shall be Type K or Type N with a standard tolerance on initial values of emf versus temperature as specified in Table 2 unless otherwise specified by the purchaser.

NOTE 1—The purchaser may specify an alternative type of thermoelement as designated in Specification E230 by indicating this deviation in the ordering documents. The supplier and the purchaser shall then agree upon a tolerance.

5.1.3 *Insulation*—The insulating material shall be either magnesia (MgO) or alumina (Al₂O₃) and shall comply with Specification E1652 Type 1 material requirements:

TABLE 3 Maximum Grain Sizes

Sheath Outside Diameter, in. [mm]	Maximum
0.0400 [1.000]	6
0.0625 [1.500]	5
0.1250 [3.000]	
0.1875 [4.500]	
0.2500 [6.000]	

5.1.3.1 A certified analysis of the composition of the insulating material as supplied to the thermocouple manufacturer shall be furnished to the purchaser. The thermocouple manufacturer shall be responsible for maintaining the purity in the finished product within the specified limits.

5.1.4 *Welding Rod*—Filler rod material used for welding on the sheath or for welding the end of the thermocouple closed shall comply with the requirements of AWS Specification A5.9 for the sheath material specified on the ordering documents.

5.2 Processing:

5.2.1 *Cleanliness*—The outer surface of the completed thermocouples at the time of delivery shall be free of residues containing nuclear poisons (such as boron and cadmium compounds) or foreign substances (such as chlorine compounds, strong acids or bases, oils, greases, or dust) that could become the source of corrosion or chemistry changes in a primary coolant or heat-transfer medium. The use of compounds containing halogens for final cleaning is prohibited. Alcohol, or methyl isobutyl ketone may be used unless otherwise specified.

5.2.2 *Annealing*—The sheath of the finished thermocouple shall be solution annealed and shall not be sensitized.

6. Inspection and Test Methods

6.1 *General Procedure*—Inspect and approve all thermocouples in accordance with the sampling procedures specified in this section and with inspection requirements stated herein and in referenced specifications. Acceptance of the sample inspection results does not relieve the thermocouple manufacturer of the responsibility that all thermocouples shall conform to all requirements of this specification and the latest issue of the referenced specifications.

6.1.1 Acceptance of thermocouples manufactured in accordance with this specification requires the satisfactory completion of the general tests specified for all thermocouples and three additional tests on selected sample thermocouples.

6.1.2 Select one sample thermocouple at random from each group of not more than 15 thermocouples from the same lot. Use sections of those sample thermocouples for the tests required in 6.7, 6.10.2, and 6.1.1. For the test in 6.10.2, fabricate a measuring junction of the same style as that in the