



Designation: **F1797–15 F1797 – 18**

Standard Test Method for Acoustic Emission Testing of Insulated and Non-Insulated Digger Derricks¹

This standard is issued under the fixed designation F1797; the number immediately following the designation indicates the year of original adoption or, in the case of revision, the year of last revision. A number in parentheses indicates the year of last reapproval. A superscript epsilon (ϵ) indicates an editorial change since the last revision or reapproval.

1. Scope

1.1 This test method covers a procedure for acoustic emission (AE) testing of digger derricks.

1.1.1 *Equipment Covered*—This test method applies to special multipurpose vehicle-mounted machines, commonly known as digger derricks. These machines are primarily designed to dig holes, set poles, and position materials and apparatus.

1.1.1.1 Insulated and non-insulated type digger derricks may be evaluated with this test method.

1.1.1.2 Digger derricks, if so equipped to position personnel or equipment, or both, may also be evaluated with this test method in conjunction with Test Method **F914**.

1.1.2 *Equipment Not Covered*—Excluded from this test method are general-purpose cranes designed only for lifting service and machines primarily designed only for digging holes.

1.2 The AE test method is used to detect and area-locate emission sources. Verification of emission sources may require the use of other nondestructive test (NDT) methods, such as radiography, ultrasonic, magnetic particle, liquid penetrant, and visual inspection.

1.3 **Warning**—This test method requires that external loads be applied to the superstructure of the vehicle under test. During the test, caution must be taken to safeguard personnel and equipment against unexpected failure or instability of the vehicle or components.

1.4 *This standard does not purport to address all of the safety concerns, if any, associated with its use. It is the responsibility of the user of this standard to establish appropriate safety, health, and environmental practices and determine the applicability of regulatory limitations prior to use.*

1.5 *This international standard was developed in accordance with internationally recognized principles on standardization established in the Decision on Principles for the Development of International Standards, Guides and Recommendations issued by the World Trade Organization Technical Barriers to Trade (TBT) Committee.*

2. Referenced Documents

2.1 *ASTM Standards*:²

[E94 Guide for Radiographic Examination Using Industrial Radiographic Film](#)

[E114 Practice for Ultrasonic Pulse-Echo Straight-Beam Contact Testing](#)

[E164 Practice for Contact Ultrasonic Testing of Weldments](#)

[E569 Practice for Acoustic Emission Monitoring of Structures During Controlled Stimulation](#)

[E610 Terminology Relating to Acoustic Emission \(Withdrawn 1991\)](#)³

[E650 Guide for Mounting Piezoelectric Acoustic Emission Sensors](#)

[E750 Practice for Characterizing Acoustic Emission Instrumentation](#)

[E976 Guide for Determining the Reproducibility of Acoustic Emission Sensor Response](#)

[E1417/E1417M Practice for Liquid Penetrant Testing](#)

[E1444/E1444M Practice for Magnetic Particle Testing](#)

¹ This test method is under the jurisdiction of ASTM Committee **F18** on Electrical Protective Equipment for Workers and is the direct responsibility of Subcommittee **F18.55** on Inspection and Non-Destructive Test Methods for Aerial Devices.

Current edition approved April 1, 2015 March 1, 2018. Published May 2015 April 2018. Originally approved in 1997. Last previous edition approved in 2014 2015 as F1797–14–15. DOI: 10.1520/F1797-15.10.1520/F1797-18.

² For referenced ASTM standards, visit the ASTM website, www.astm.org, or contact ASTM Customer Service at service@astm.org. For *Annual Book of ASTM Standards* volume information, refer to the standard's Document Summary page on the ASTM website.

³ The last approved version of this historical standard is referenced on www.astm.org.

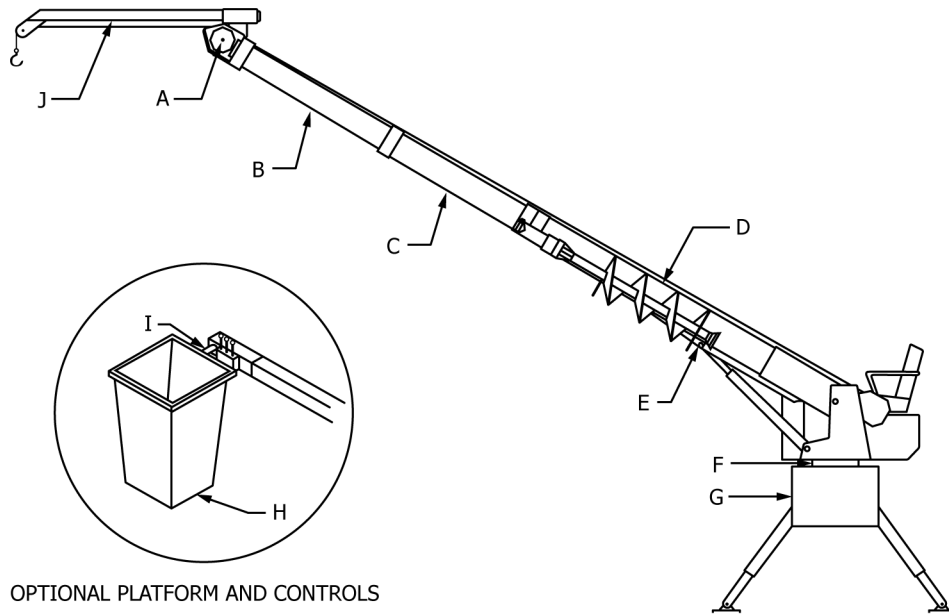

OPTIONAL PLATFORM AND CONTROLS

FIG. 1 Digger Derrick Nomenclature

F914 Test Method for Acoustic Emission for Insulated and Non-Insulated Aerial Personnel Devices Without Supplemental Load Handling Attachments

2.2 Other Standards:

ASNT Recommended Practice SNT-TC-1A— Personnel Qualification and Certification in Nondestructive Testing⁴

ANSI A10.31 Digger Derricks—Safety Requirements, Definitions, and Specifications⁵

EMI Nomenclature and Specifications for Truck-Mounted Extensible Aerial Devices, Articulating Aerial Devices, Digger-Derricks⁶

3. Terminology

3.1 Definitions:

3.1.1 *acoustic emission, AE*—the class of phenomena whereby elastic waves are generated by the rapid release of energy from a localized source or sources within a material, or the transient elastic wave(s) so generated.

3.1.1.1 Discussion—

acoustic emission is the recommended term for general use. Other terms that have been used in AE literature include (1) stress wave emission, (2) micro-seismic activity, and (3) emission or acoustic emission with other qualifying modifiers.

3.1.2 *amplitude (acoustic emission signal amplitude)*—the peak voltage of the largest excursion attained by the signal waveform from an emission event.

3.1.3 *amplitude distribution*—a display of the number of acoustic emission events with signals that exceed an arbitrary amplitude as a function of amplitude.

3.1.4 *attenuation*—loss of energy per unit distance, typically measured as loss of signal peak amplitude with unit distance from the source of emission.

3.1.5 *channel*—an input to the main AE instrument that accepts a preamplifier output.

3.1.6 *commoned*—two or more sensors interconnected such that the sensor outputs are electronically processed by a single channel without differentiation of sensor origin. (syn. teed)

3.1.7 *count, n*—(acoustic emission count) the number of times the acoustic emission signal amplitude exceeds a preset threshold during any selected portion of a test.

3.1.8 *decibel, dB*—a reference scale that expresses the logarithmic ratio of a signal peak amplitude to a fixed reference amplitude.

⁴ Available from American Society of Nondestructive Testing, 4153 Arlingate Plaza, Caller #28518, Columbus, OH 43228.

⁵ Available from the American National Standards Institute, 1430 Broadway, New York, NY 10018.

⁶ Available from the Equipment Manufacturer’s Institute, 410 N. Michigan Ave., Chicago, IL 60611.

$$\text{Signal peak amplitude (dB)} = 20 \log_{10} \frac{A_1}{A_0} \quad (1)$$

where:

- A_0 = 1 μ V at the sensor output (before amplification), and
 A_1 = peak voltage of the measured acoustic emission signal.

dB Value	Acoustic Emission Reference Scale	
	Voltage At Sensor Output	Voltage at Integral Preamp Sensor Output (40 dB Gain)
0	1 μ V	100 μ V
20	10 μ V	1 mV
40	100 μ V	10 mV
60	1 mV	100 mV
80	10 mV	1 V
100	100 mV	10 V

3.1.9 *event (acoustic emission event)*—a local material change giving rise to acoustic emission.

3.1.10 *event count, N*—the number obtained by counting each discerned acoustic emission event once.

3.1.11 *first-hit*—a mode of operation of AE monitoring equipment in which an event occurring on one channel will prevent all other channels from processing data for a specified period of time. The channel with a sensor closest to the physical location of the emission source will then be the only channel processing data from that source.

3.1.12 *insulator*—any part of the digger derrick such as, but not limited to, any of the extensible boom sections or supporting structure, made of a material having a high dielectric strength, usually FRP or the equivalent.

3.1.13 *noise*—any undesired signal that tends to interfere with the normal reception or processing of the desired signal.

3.1.14 *qualified personnel*—personnel who, by possession of a recognized degree, certificate, professional standing, or skill, and who, by knowledge, training, and experience, have demonstrated the ability to deal with problems relating to the subject matter, the work, or the project.

3.1.15 *signal (emission signal)*—a signal obtained by detection of one or more acoustic emission events.

3.1.16 For definitions of other terms in this test method, refer to Definitions E610 and the EMI Nomenclature and Specifications.

3.2 Definitions of Terms Specific to This Standard:

3.2.1 *auger*—the hole-boring tool of the digger.

3.2.2 *authorized person*—a qualified person approved and assigned by the user to perform a specific type of duty or duties or to be at a specific location or locations at the job site.

3.2.3 *boom angle indicator*—a device that indicates the angle between the boom and a horizontal plane.

3.2.4 *boom pin*—the horizontal shaft about which the boom pivots as it is raised or lowered relative to the turntable.¹⁸

3.2.5 *boom tip sheave*—the sheave, located at the tip of a boom, that carries the winch line.

3.2.6 *capacity chart*—a chart that indicates the load capacity or rated capacity of the digger derrick, and by the choice of the user reflects either the load capacity or the rated capacity.

3.2.7 *centerline of rotation*—the vertical axis about which the digger derrick rotates.

3.2.8 *critical members*—those components, members, or structures in a digger derrick whose failure would cause catastrophic failure of the digger derrick system.

3.2.9 *design stress*—the maximum stress at which the component is designed to operate under conditions of rated capacity.

3.2.10 *digger*—the mechanism that drives the auger.

3.2.11 *extension cylinder*—the hydraulic cylinder or cylinders that extend the boom.

3.2.12 *instability*—a condition of a mobile unit in which the sum of the moments tending to overturn the unit is equal to or exceeds the sum of the moments tending to resist overturning.

3.2.13 *intermediate boom (C)⁷*—structural member or members that extend and are located between the upper and lower booms.

3.2.14 *jib*—an auxiliary boom that attaches to the upper boom tip to extend the reach of the boom.

3.2.15 *lift cylinder*—a hydraulic cylinder that lifts the boom.

3.2.16 *load block*—a component consisting of a sheave or sheaves and a hook that is used for multiple parting of the load line.

3.2.17 *load capacity*—the maximum load, specified by the manufacturer, that can be lifted by the mobile unit at regular intervals of load radius and boom angle, through the specified ranges of boom elevation, extension, and rotation, with options installed and inclusive of stability requirements.

⁷ Letters in parentheses refer to the corresponding letters in Table 1 and Fig. 1.

- 3.2.18 *load line*—the load hoisting line.
- 3.2.19 *lower boom (D)*—the structural member, attached to the turntable, that supports the extensible boom or booms.
- 3.2.20 *manufacturer*—one who originally constructs the digger derrick.
- 3.2.21 *model*—manufacturer’s designation for digger derrick specified.
- 3.2.22 *non-destructive testing*—the examination by various means of devices and their components without alteration of original components, so that they may function as before.
- 3.2.23 *operator*—the person actually engaged in the operation of the digger derrick.
- 3.2.24 *outrigger cylinder*—the hydraulic cylinder that extends the outrigger.
- 3.2.25 *outriggers (L)*—the structural members that are extended or deployed to assist in stabilizing the mobile unit.
- 3.2.26 *pedestal (G)*—the stationary base of the digger derrick that supports the turntable.
- 3.2.27 *platform (H)*—the optional personnel-carrying component of a digger derrick, such as a bucket, basket, stand, or equivalent.
- 3.2.28 *platform pin*—the horizontal pin about which the optional platform rotates relative to the boom.
- 3.2.29 *structural components*—those elements of a digger derrick that are subjected to stress during operation.
- 3.2.30 *turntable (F)*—the structure above the rotation bearing that supports the booms.
- 3.2.31 *ultimate strength*—for materials that do not have a clearly defined yield strength, the stress level at which failure of a material will occur.
- 3.2.32 *upper boom (B)*—the structural member that extends the farthest, and that supports the boom tip sheave, or the optional platform, or both.
- 3.2.33 *upper boom tip (A)*—the end of the boom farthest from the turntable.

4. Summary of Test Method

4.1 This test method consists of applying a predetermined load to a digger derrick while it is being monitored by sensors that are sensitive to acoustic emissions (AE) caused by active defects. These acoustic emissions can be generated by, but are not limited to, the following: crack nucleation, movement, or propagation in the metal components; or matrix crazing, delamination or fiber breakage of the fiber reinforced plastic (FRP) material, or both.

4.2 The digger derrick is loaded at a uniform rate until a predetermined load is reached, which is held for a period of time. The load is removed and the cycle is repeated. Acoustic emissions are monitored for the components being evaluated during both cycles, and the data is reviewed.

5. Significance and Use

5.1 This test method permits testing of the major components of a digger derrick generated by the rapid release of energy from localized sources within the digger derrick under controlled loading. The energy releases occur during intentional application of a predetermined load. These energy releases can be monitored and interpreted by qualified individuals. Acceptance/rejection criteria are beyond the scope of this test method. The test may be discontinued at any time to investigate a particular area of concern, or to prevent a fault from continuing to ultimate failure of the digger derrick resulting from the application of the test load.

5.2 This test method provides a means of detecting acoustic emission sources that may be defects, irregularities, or both, affecting the structural integrity or intended use of the aerial personnel device.

5.3 Significant sources of acoustic emission found with this test method shall be evaluated by either more refined acoustic emission test techniques or by other nondestructive methods (visual, liquid penetrant, radiography, ultrasonic, magnetic particle, etc.). Other nondestructive methods may be required in order to precisely locate defects in the digger derrick, and to estimate their size. Additional tests are outside the scope of this test method.

5.4 Defective areas found in digger derricks by this test method should be repaired and retested as appropriate. Repair procedure recommendations are outside the scope of this test method. Repair procedure recommendations are outside the scope of this test method.

6. Personnel Qualifications

6.1 The test method shall be performed by qualified personnel. Qualification shall be in accordance with an established written program prepared by a person familiar with design, manufacture, and operation of digger derricks. The program shall include an established format of ASNT SNT-TC-1A for training, qualification, and certification of personnel for conducting AE testing.

NOTE 1—Personnel performing non-destructive testing shall be at least Level 1 in visual, liquid penetrant, ultrasonic, magnetic particle, and AE. Subsequent test evaluation shall be made by personnel certified Level 2 (visual, liquid penetrant, ultrasonic, magnetic particle, and AE) in accordance with ASNT SNT-TC-1A guidelines.

6.2 Acoustic emission test personnel shall be familiar with the design, manufacture, and operation of insulated digger derricks. Relevant information is contained in ANSI A10.31 and manufacturers’ operating and service manuals.

7. Acoustic Emission Instrumentation

7.1 The AE instrument shall be capable of data acquisition from discrete channels using 60 kHz and 150 kHz sensors. The number of AE instrument channels shall be determined by the attenuation characteristics of the digger derrick in order to provide coverage of those components identified in **Table 1**. Experience shows that a minimum of eight channels of data acquisition is required. The instrument should be capable of recording the following: time, events, counts, amplitude and load. Hard copy records shall be provided by the instrument or available through a direct interface. Refer to the description of mandatory instrumentation characteristics in **Annex A1**.

NOTE 2—**Annex A1** requires the use of a minimum of eight channels.

NOTE 3—The sensors used by most testing agencies are resonant at 60 kHz for FRP components and 150 kHz for metal components. Selection of sensors other than these may significantly affect test results.

8. Test Preparation

8.1 Prior to the AE test, a visual evaluation of the digger derrick shall be performed to determine, as far as practical, that the derrick is free from any condition that may prohibit the test or adversely affect the test results.

8.2 The components to be monitored in a digger derrick shall include, but not be limited to, those specified in **Table 1**. Additional channels and sensors may be used to supplement the minimum test requirements and improve location resolution.

8.3 Position the sensors on the FRP and metal portions of the components to be monitored. The extent of the coverage is determined by the number of sensors used and the attenuation characteristics of the individual components, and can be verified by a simulated AE technique as indicated in Guide **E976**. Record the amplitude of the simulated AE source at a distance of 12 in. (304 mm) from the sensor as a reference. Continue to move the simulated AE source away from the sensor until the amplitude is no more than 15 dB less than the reference amplitude. This will establish the maximum effective coverage of the sensor.

8.4 The mounting of sensors shall be in accordance with Practice **E569** and **E650**. The couplant used shall not affect the integrity of the digger derrick.

NOTE 4—The couplant should be compatible with the digger derrick; not a possible cause of contamination. The couplant should be completely removable from the surface after testing, leaving the original surface intact.

9. AE Instrumentation System Performance Check

9.1 Performance verification shall be made with an AE simulator immediately prior to application of test load. This simulator should be capable of producing a transient elastic wave having an amplitude representative of the AE signals to be recorded.

9.2 The AE simulator may be gas jet, pencil lead break technique or an electronically induced event or equivalent.

9.3 The detected peak amplitude of the simulated event at a fixed distance, typically 6 to 9 in. (152 to 228 mm), from each sensor shall not vary more than 6 dB from the average of all the sensors on the same type material. The detected peak amplitude of any sensor shall not exceed 90 dB to avoid saturation of amplifier(s).

10. System Calibration

10.1 Subject the AE system to a thorough calibration and functional check to verify accurate performance in accordance with the manufacturer’s specification, in conjunction with Practice **E750**. Perform calibration annually as a minimum in accordance with a written calibration procedure. Include in the calibration, as a minimum: calibration of threshold levels, amplitude measurement circuits, count measurement circuits, AE sensors and load measuring devices.

10.2 Subject the AE system to a routine performance check, which shall include as a minimum, verification of threshold levels and amplitude measurements.

TABLE 1 Digger Derrick Components That Shall be Monitored with Acoustic Emission

Component	To be Monitored in 11.1
Upper Boom Tip	A
Upper Boom	B
Intermediate Boom(s), if equipped	C
Lower Boom	D
Lower Boom Lift Cylinder Attach Bracket	E
Turntable	F
Pedestal	G

11. Procedure

11.1 Test the digger derrick in a position such that the components indicated in **Table 1** can be monitored. This position shall be with all booms extended at an angle of 15 degrees (or the first angle on the capacity placard greater than zero). **Fig. 2** shows the recommended test positions. The insulated boom test load shall be 1.18 % of its maximum rated capacity at the selected angle. Alternatively, if the placard specifies an ANSI A10.31 stability test load and angle, this will be used with no multiplication factor. This will test the intermediate and lower booms.

11.2 Test the insulated section with the upper stage only extended at a 15 degree angle (or the first angle greater than zero listed on the capacity chart) and at 1.18X the load shown for this position. This will test the upper boom, turntable, pedestal, rotation bearing attachment, and lower boom cylinder attachment.

NOTE 5—For derricks with synchronized or dependent upper stages, it will be necessary to only test as per **11.1**.

11.3 The manufacturer’s annual torque inspection procedure for rotation bearing fasteners must have been completed within 12 months prior to performing the acoustic emission test. All accessible rotation bearing fasteners must be checked prior to the test.

11.4 Attach the load measuring device to the load application system, which in turn shall attach to an adequate dead weight or anchor.

11.5 Loads should be applied to the actual load line used for material handling. The line may run just over the outer sheave and a loading mechanism or stiffer line attached to minimize line stretch.

11.6 All components of the load application system shall be capable of supporting the test load.

11.7 Perform the loading sequence as shown in **Fig. 3**.

11.8 Platforms should be tested separately in accordance with Test Method **F914**.

11.9 If the unit is equipped with a jib, it should be tested separately with booms retracted so as not to require the monitoring of the digger derrick during the jib tests, except for the interface between the jib and derrick. The jib shall be tested in its fully extended position at an angle of 0-degrees. The test load shall be 118 % of its rated capacity. Where applicable the actual loadline shall be used.

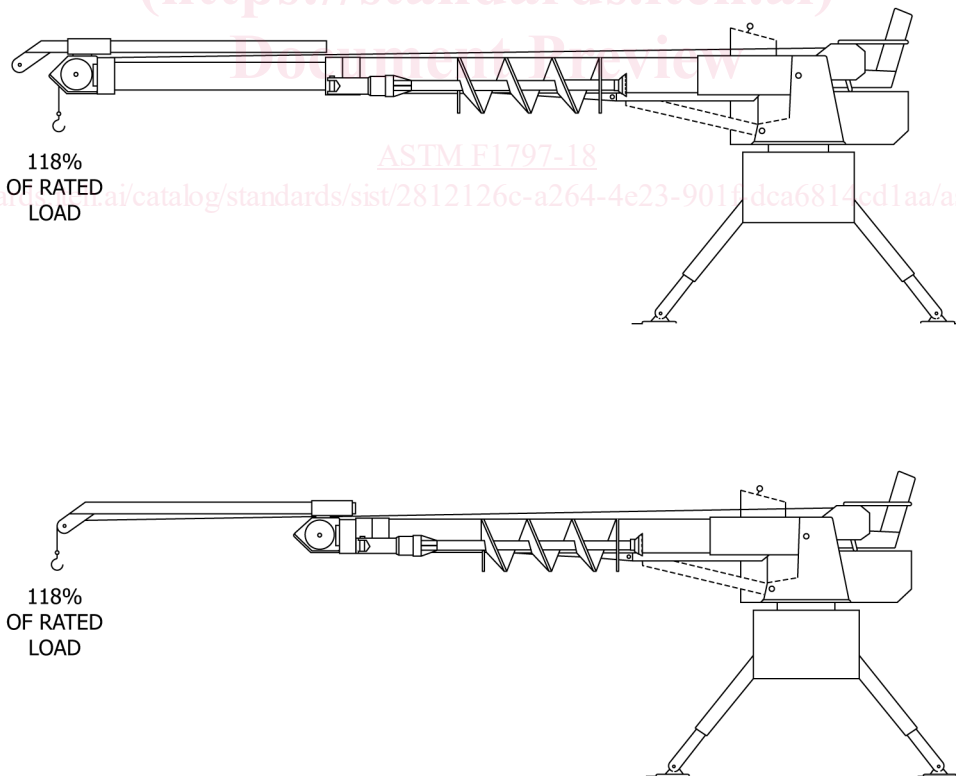

- Notes (Apply To All Tests):
- (1) Position truck in most favorable stable position, on firm, level ground.
 - (2) Extend outriggers.
 - (3) Refer to manufacturers load charts, operational manuals, and decals before testing.
 - (4) Maintain weights (test loads) within 2 ft of the ground at all times.

FIG. 2 Digger Derrick Recommended Test Positions and Test Loads