



Designation: ~~D3385~~—~~09~~ **D3385 – 18**

Standard Test Method for Infiltration Rate of Soils in Field Using Double-Ring Infiltrometer¹

This standard is issued under the fixed designation D3385; the number immediately following the designation indicates the year of original adoption or, in the case of revision, the year of last revision. A number in parentheses indicates the year of last reapproval. A superscript epsilon (ϵ) indicates an editorial change since the last revision or reapproval.

This standard has been approved for use by agencies of the U.S. Department of Defense.

1. Scope Scope*

1.1 This test method describes a procedure for field measurement of the rate of infiltration of liquid (typically water) into soils using double-ring infiltrometer.

1.2 The infiltrometer is installed by driving into the soil. The infiltrometer also may be installed in a trench excavated in dry or stiff soils.

1.3 Soils should be regarded as natural occurring ~~fine or coarse-grained~~ soils or processed materials or mixtures of natural soils and processed materials, or other porous materials, and which are basically insoluble and are in accordance with requirements of ~~1.5~~ **1.6**.

1.4 This test method is particularly applicable to relatively uniform fine-grained soils, with an absence of very plastic (fat) clays and gravel-size particles and with moderate to low resistance to ring penetration.

1.5 This test method may be conducted at the ground surface or at given depths in pits, and on bare soil or with vegetation in place, depending on the conditions for which infiltration rates are desired. However, this test method cannot be conducted where the test surface is below the groundwater table or perched water table.

1.6 This test method is difficult to use or the resultant data may be unreliable, or both, in very pervious or impervious soils (soils with a hydraulic conductivity greater than about 10^{-2} cm/s or less than about $1 \times 10^{-6-5}$ cm/s) or in dry or stiff soils ~~that most likely will~~ if these fracture when the rings are installed. For soils with hydraulic conductivity less than $1 \times 10^{-6-5}$ cm/s refer to Test Method **D5093**.

1.7 This test method cannot be used directly to determine the hydraulic conductivity (coefficient of permeability) of the soil (see **5.2**).

1.8 *Units*—The values stated in SI units are to be regarded as the standard. The inch-pound units given in parentheses are mathematical conversions, which are provided for information purposes only and are not considered standard.

1.9 *This standard does not purport to address all of the safety concerns, if any, associated with its use. It is the responsibility of the user of this standard to establish appropriate ~~safety~~ safety, health, and ~~health~~ environmental practices and determine the applicability of regulatory limitations prior to use.*

1.10 *This international standard was developed in accordance with internationally recognized principles on standardization established in the Decision on Principles for the Development of International Standards, Guides and Recommendations issued by the World Trade Organization Technical Barriers to Trade (TBT) Committee.*

2. Referenced Documents

2.1 *ASTM Standards:*²

D653 Terminology Relating to Soil, Rock, and Contained Fluids

D1452 Practice for Soil Exploration and Sampling by Auger Borings

D2216 Test Methods for Laboratory Determination of Water (Moisture) Content of Soil and Rock by Mass

¹ This test method is under the jurisdiction of ASTM Committee **D18** on Soil and Rock and is the direct responsibility of Subcommittee **D18.04** on Hydrologic Properties and Hydraulic Barriers.

Current edition approved ~~March 1, 2009~~ March 1, 2018. Published ~~March 2009~~ April 2018. Originally approved in 1975. Last previous edition approved in ~~2003~~ 2009 as ~~D3385—03~~ **D3385 – 09**. DOI: ~~10.1520/D3385-09~~ **10.1520/D3385-18**.

² For referenced ASTM standards, visit the ASTM website, www.astm.org, or contact ASTM Customer Service at service@astm.org. For *Annual Book of ASTM Standards* volume information, refer to the standard's Document Summary page on the ASTM website.

*A Summary of Changes section appears at the end of this standard

D2488 Practice for Description and Identification of Soils (Visual-Manual Procedures)

D3740 Practice for Minimum Requirements for Agencies Engaged in Testing and/or Inspection of Soil and Rock as Used in Engineering Design and Construction

D5093 Test Method for Field Measurement of Infiltration Rate Using Double-Ring Infiltrometer with Sealed-Inner Ring

3. Terminology

3.1 *Definitions*—For common definitions of technical terms in this standard, refer to Terminology **D653**.

3.2 *Definitions of Terms Specific to This Standard:*

3.2.1 *incremental infiltration velocity*—the quantity of flow per unit area over an increment of time. It has the same units as the infiltration rate.

3.2.2 *infiltration*—the downward entry of liquid into the soil.

3.2.3 *infiltration rate*—~~a selected the rate, based on measured incremental infiltration velocities, at which liquid can enter the soil under specified conditions, including the presence of an excess of liquid. It has the dimensions of velocity (that is, cm conditions. During infiltration, this rate may decrease with time until reaching a quasi-steady value.~~³~~cm⁻²h⁻¹ = cm h⁻¹).~~

3.2.4 *infiltrometer*—a device for measuring the rate of entry of liquid into a porous body, for example, water into soil.

4. Summary of Test Method

4.1 The double-ring infiltrometer method consists of ~~driving~~ installing two open cylinders, one inside the other, into the ground, partially filling the rings with water or other liquid, and then maintaining the liquid at a constant level. The volume of liquid added to the inner ring, to maintain the liquid level constant is the measure of the volume of liquid that infiltrates the soil. The volume infiltrated during timed intervals is converted to an incremental infiltration ~~velocity,~~ velocity by dividing by the area of the inner ring, usually expressed in centimetrecentimeter per hour or (or inch per hourhour) and plotted versus elapsed time. The ~~maximum-steady-state~~ maximum steady-state or average incremental infiltration velocity, depending on the purpose/application of the test is equivalent to the infiltration rate.

5. Significance and Use

5.1 This test method is useful for field measurement of the infiltration rate of soils. Infiltration rates have application to such studies as liquid waste disposal, evaluation of potential septic-tank disposal fields, leaching and drainage efficiencies, irrigation requirements, water spreading and recharge, and canal or reservoir leakage, among other applications.

5.2 Although the units of infiltration rate and hydraulic conductivity of soils are similar, there is a distinct difference between these two quantities. They cannot be directly related unless the hydraulic boundary conditions are known, such as hydraulic gradient and the extent of lateral flow of water, or can be reliably estimated.

5.3 The purpose of the outer ring is to promote one-dimensional, vertical flow beneath the inner ring.

5.4 Many factors affect the infiltration rate, for example the soil structure, soil layering, condition of the soil surface, degree of saturation of the soil, chemical and physical nature of the soil and of the applied liquid, head of the applied liquid, temperature of the liquid, and diameter and depth of embedment of rings.³ Thus, tests made at the same site are not likely to give identical results and the rate measured by the test method described in this standard is primarily for comparative use.

5.5 Some aspects of the test, such as the length of time the tests should be conducted and the head of liquid to be applied, must depend upon the experience of the user, the purpose for testing, and the kind of information that is sought.

NOTE 1—The quality of the result produced by this standard is dependent on the competence of the personnel performing it, and the suitability of the equipment and facilities used. Agencies that meet the criteria of Practice **D3740** are generally considered capable of competent and objective testing/sampling/inspection/etc. Users of this standard are cautioned that compliance with Practice **D3740** does not in itself assure reliable results. Reliable results depend on many factors; Practice **D3740** provides a means of evaluating some of those factors.

6. Apparatus

6.1 *Infiltrometer Rings*—Cylinders approximately 500 mm (20 in.) high and having diameters of about 300 and 600 mm (12 and 24 in.). Larger cylinders may be used, ~~providing used but~~ the ratio of the outer to inner ~~cylinders~~ cylinder diameters is about ~~two~~ two times. Cylinders can be made of 3-mm ($\frac{1}{8}$ -in.), hard-alloy, aluminum sheet or other material sufficiently strong to withstand hard driving, with the bottom edge ~~beveled~~ beveled (see Fig. 1). The ~~beveled~~ beveled edges shall be kept sharp. Stainless steel or strong plastic rings may have to be used when working with corrosive fluids.

6.2 *Driving Caps*—Disks of 13-mm ($\frac{1}{2}$ -in.) thick hard-alloy aluminum with centering pins around the edge, or preferably having a recessed groove about 5 mm (0.2 in.) deep with a width about 1 mm (0.05 in.) wider than the thickness of the ring. The diameters of the disks should be slightly larger than those of the infiltrometer rings.

³ Discussion of factors affecting infiltration rate is contained in the following reference: Johnson, A. I., *A Field Method for Measurement of Infiltration*, U.S. Geological Survey Water-Supply Paper 1544-F, 1963, pp. 4-9.

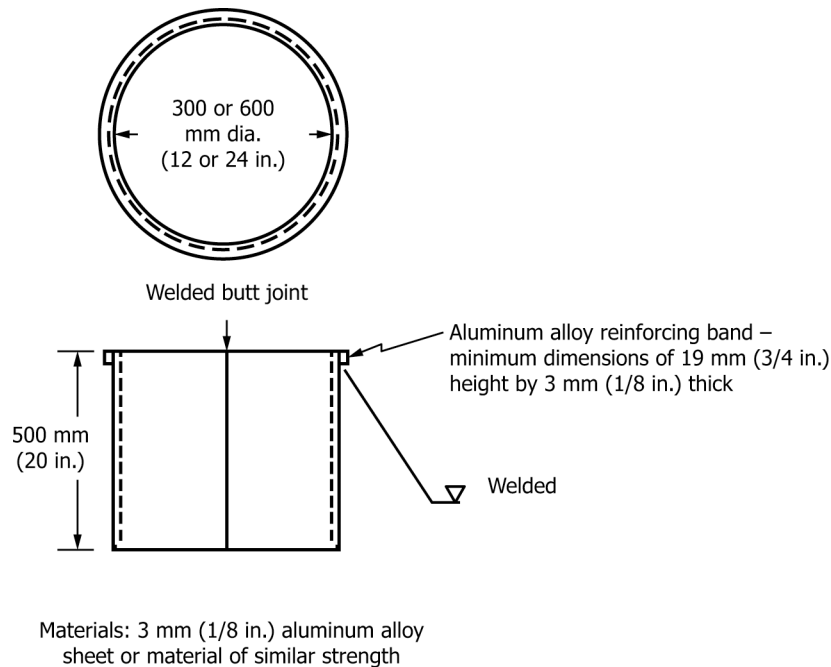

FIG. 1 Infiltrometer Construction

6.3 *Driving Equipment*—A 5.5-kg (12-lb) maul or sledge and a 600 or 900-mm (2 or 3-ft) length of wood approximately 50 by 100 mm or 100 by 100 mm (2 by 4 in. or 4 by 4 in.), or a jack and reaction of suitable size.

6.4 *Grout*—A commercial bentonite grout product and water mix having 30 % bentonite solids for filling the trenches and sealing the rings in place (see 8.5).

6.5 *Depth Gage*—A hook gage, steel tape or rule, or length of steel or plastic rod pointed on one end, for use in measuring and controlling the depth of liquid (head) in the infiltrometer ring, when either a graduated Mariotte tube or automatic flow control system is not used.

6.6 *Splash Guard*—Several pieces of rubber sheet or burlap 150 mm (6 in.) square. A large piece of cheese cloth folded several times can also be used as a splash guard.

6.7 *Rule or Tape*—Two metre (6-ft) steel tape or 300-mm (1-ft) steel rule. A steel tape having a length of at least 2 m (6.5 ft) or a steel rule having a length of at least 300 mm (1 ft).

6.8 *Tamp*—Any device that is basically rigid, has a handle not less than 550 mm (22 in.) in length, and has a tamping foot with an area ranging from 650 to 4000 mm² (1 to 6 in.²) and a maximum dimension of 150 mm (6 in.).

6.9 *Shovels*—One long-handled shovel and one trenching spade; hand shovel or trowel (for excavating a trench).

6.10 *Liquid Containers:*

6.10.1 One 200-L (55-gal) barrel or other container having a minimum volume of 200 L (55 gal) for the main liquid supply, along with a length of rubber hose to siphon liquid from the barrel to fill the calibrated head tanks (see 6.9.36.10.3).

6.10.2 A 13-L (12-qt) pail or carboy having a minimum volume capacity of 13 L (12 qt) for initial filling of the infiltrometers.

6.10.3 Two calibrated head tanks for measurement of liquid flow during the test. These may be either graduated cylinders or Mariotte tubes having a minimum volume capacity of about 3000 mL (3.17 qt) (see Note 2 and Note 3 and Fig. 2). In higher permeability soils, the Mariotte bottle used for the inner and outer rings may have a larger volume to avoid having to refill the bottle during testing.

NOTE 2—Constant-level float valves have been eliminated for simplification of the illustration.

NOTE 3—It is useful to have one head tank with a capacity of three times that of the other because the area of the annular space between the rings is about three times that of the inner ring.

NOTE 4—In many cases, the volume capacity of these calibrated head tanks must be significantly larger than 3000 mL (3.17 qt), especially if the test has to continue overnight. Capacities of about 50 L (13 gal) would not be uncommon.

6.11 *Liquid Supply*—Water, or preferably, liquid of the same quality and temperature as that involved in the problem being examined. The liquid used must be chemically compatible with the infiltrometer rings and other equipment used to contain the liquid.

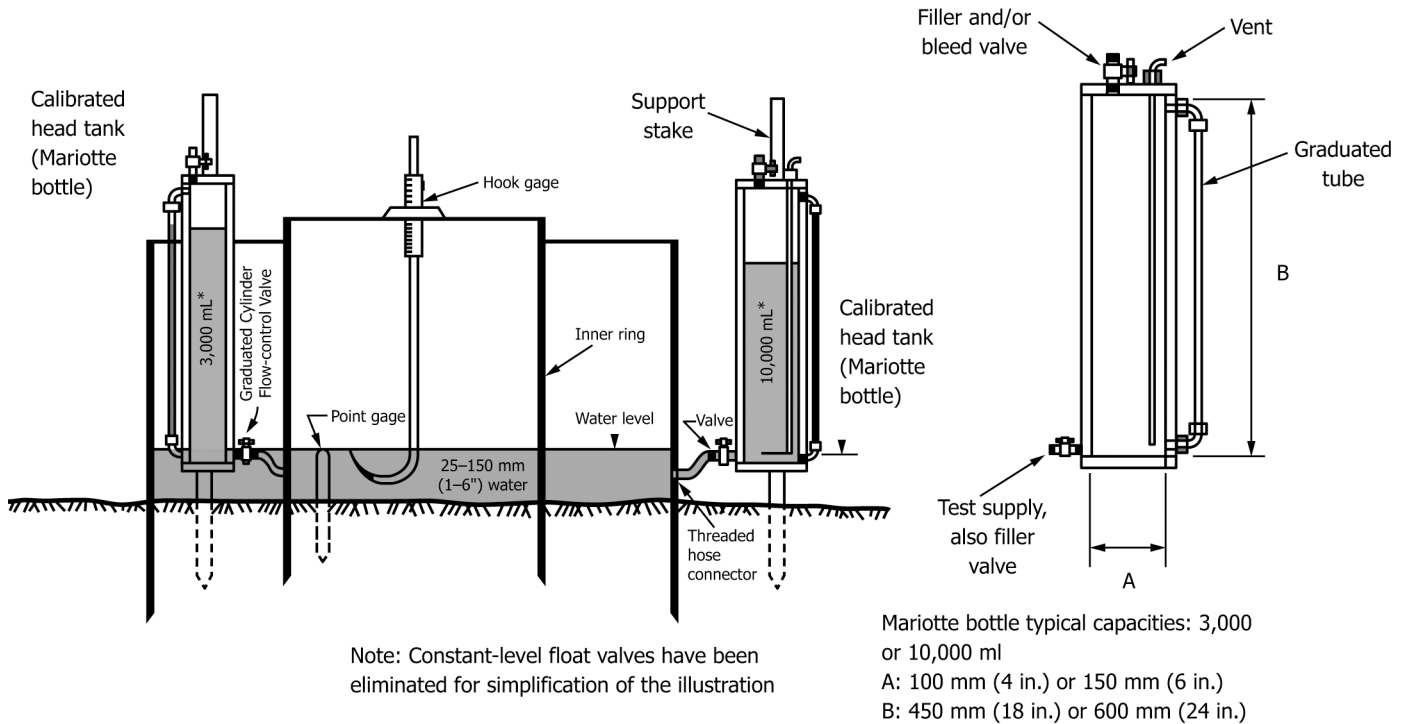

NOTE 1—Constant-level float valves have been eliminated for simplification of the illustration

FIG. 2 Ring Installation and Mariotte Tube/Bottle Details

NOTE 5—To obtain maximum infiltration rates, the liquid should be free from suspended solids and the temperature of the liquid should be higher than the soil temperature. This will tend to avoid reduction of infiltration from blockage of voids by particles or gases coming out of solution.

6.12 *Watch or Stopwatch*—A stopwatch would only be required for high infiltration rates. Used to measure the time during infiltration.

6.13 *Level*—A carpenter’s level or bull’s-eye (round) level.

6.14 *Thermometer*—With accuracy/resolution of 0.5°C (1°F) and capable of measuring ground temperature/soil temperature at depth below the ground surface.

6.15 *Rubber Hammer (mallet)*.

6.16 *pH Paper*, in 0.5 increments.

6.17 *Recording Materials*—Record books and graph paper, or special forms with graph section (see Fig. 3 and for Fig. 4): an example of a data form).

6.18 *Hand Auger*—Orchard-type (barrel-type) auger with 75-mm (3-in.) diameter, 225-mm (9-in.) long barrel and a rubber-headed tire hammer for knocking sample out of the auger. This apparatus is optional.

6.19 *Float Valves*—Two constant level float valves (carburetors or bob-float types) with support stands. This apparatus is optional.

6.20 *Covers and Dummy Tests Set-Up*—For long-term tests in which evaporation of fluid from the infiltration rings and unsealed reservoirs can occur (see 8.2.1).

7. Calibration

7.1 Rings:

7.1.1 Determine the area of each ring and the annular space between rings before initial use and before reuse after anything has occurred, including repairs, which may affect the test results significantly.

7.1.2 Determine the area using a measuring technique that to the nearest 10 mm² will provide (0.15 in.²—an overall accuracy of ±1%—) or better. Measure the inside diameter (ID) of the outer ring at least six equally-spaced locations around the ID of the ring. Measure both the inside diameter (ID) and the outside diameter (OD) of the inner ring at least at six equally-spaced locations around the ring.

7.1.3 The area of the annular space between rings is equal to the internal area of the 600-mm (24-in.) ring minus the external area of the 300-mm (12-in.) ring.